

PDSM010

Particle Sensor Module

Features

- ◆ Customized sensitivity for efficient control in application
- ◆ Detects approx. $1\mu\text{m}$ particle
- ◆ MCU F/W setting by factory
- ◆ Excellent long term reliability and easy maintenance
- ◆ LPO Output (Low Pulse Occupancy)
- ◆ External Noise Protection by Shield Can Extension



Product Summary

PDSM010 detects approx. $1\mu\text{m}$ particle such as house dust, pollen, germs, dust mites and cigarette smoke and measures the concentration of floating particles in a room space up to maximum 30m^3 .

This sensor is an ideal product for automatic room air monitoring system such as an air purifier.

PDSM010's signal is converted to LPO output by internal circuit and MCU program. Also, the

sensor's filter circuit and MCU program can remove a noise in order to operate more stably when a noise is in-flowed in the signal.

PDSM010 has advantages of both stable detecting ability and high manufacturing efficiency.

The sensor does not have an additional control point (VR Trimmer) on the device unlike its previous model (DSM). It prevents potential malfunction often occurred by user's arbitrary modification.

Applications

- ◆ Air cleaners, Air conditioners
- ◆ Ventilation System, Fan Control
- ◆ IAQ Monitoring & Control
- ◆ IoT Device

Product Specification

Ta = 25°C

Parameter	Symbol	Rating	Unit
Supply Voltage	V _{cc}	5V ± 10%	V
Supply Current (@ 5V)	I _{cc}	< 85	mA
Storage Temperature Range	T _{stg}	-20 ~ 80	°C
Operating Temperature Range	T _a	-10 ~ 65	°C
Operating Humidity Range (Without dew condensation)	RH	< 95	%RH
Particle Detection Range *1	Detectable Particle Size : > 0.85µm		
	Concentration : 300µg/m ³ Count : 8,000 pcs / 283m ³		
Output Signal	LPO (Low Pulse Occupancy) - Low Logic Pulse Active Output		
Weight	22.5g		
Size	(W) 59 mm x (H) 45 mm x (D) 17 mm		

*1 : It refers to the range which accuracy tolerance is guaranteed.

Output Characteristics

V_{cc} = 5V, Ta = 25°C

Parameter	Symbol	Condition	Min.	Typ.	Max.	Unit
Vout2 at high *1	Voh	No particle	-	V _{cc}	-	V
Vout2 at low *2	Vol	Particle	-	-	0.8	V
Time for stabilization *3			1	-	-	minute

*1 : Vout 2 at the highest state when particles are not detected. (=clean room)

*2 : Vout 2 at the lowest state when particles are detected.

*3 : It refers to the heating time to create stable air flow after power-on.

Life Expectancy

Light Emitter MTTF : 49,099 hrs (ALT Test Condition : 85°C, 1,000hrs)

Internal Configuration

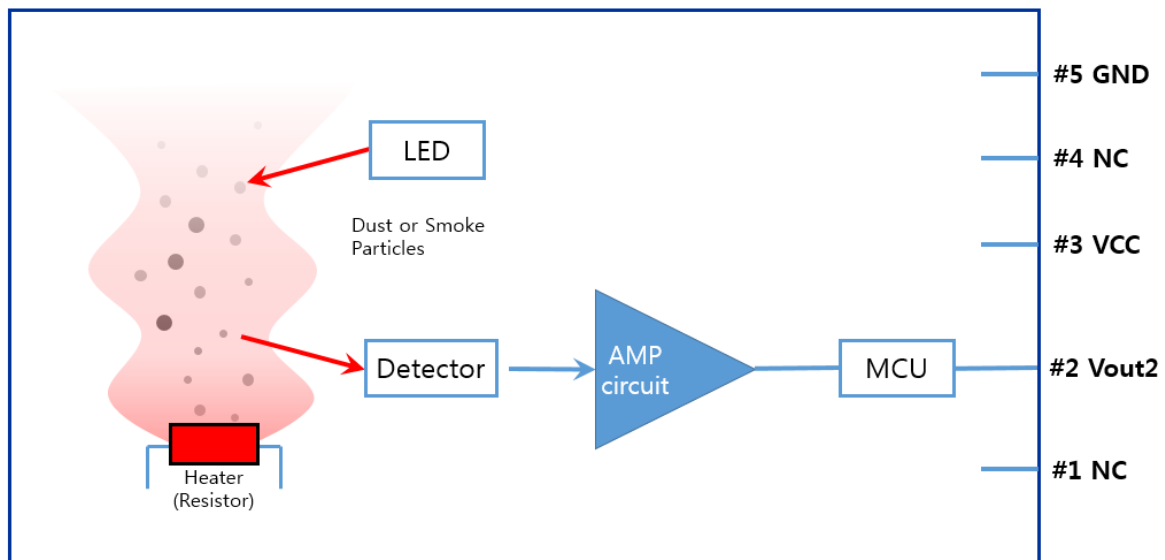

Figure 1 Internal Configuration

According to above Block Diagram, PDSM010 consists of infrared LED for particle detection, Photo TR for scattered infrared signal, OP-Amp for signal amplification.

The principle of particle detection is that while in-

flowed particle is passing by the measuring scope through upstream with self-heating of heater, the lights from LED is scattered by particle and is recognized as a signal at detector. The signal from detector is filtered by circuit and MCU, and it is transformed into a LPO signals.

I / O Connector Specifications

Pin number	Pin name	Description
1	NC	No connect
2	Vout 2	Vout 2 output (LPO)
3	Vcc	DC 5V Input
4	NC	No connect
5	GND	Ground

PIN Description

NC (Pin #1)

No connect

Vout 2 (Pin #2)

This Pin is used to transform small dust signals into LPO (Low Pulse Occupancy) signal (Active Low). Refer to the attached additional 'Application Note'.

Vcc (Pin #3)

The Pin of DC 5V input Power.

For stable operation, the power supply range should be adjusted within $\pm 10\%$ and Ripple has to be below 30mV.

NC (Pin #4)

No connect

GND (Pin #5)

Pin #5 is used for Ground.

Connector Description

Model name	Part No.		Description	Connector's maker
PDSM010	Wafer	S5B-EH	2.5mm pitch	J.S.T.
	Housing	EHR-5		

**** Please use AWG24 or thicker wire to connect PDSM010.**

Basic Circuit Diagram

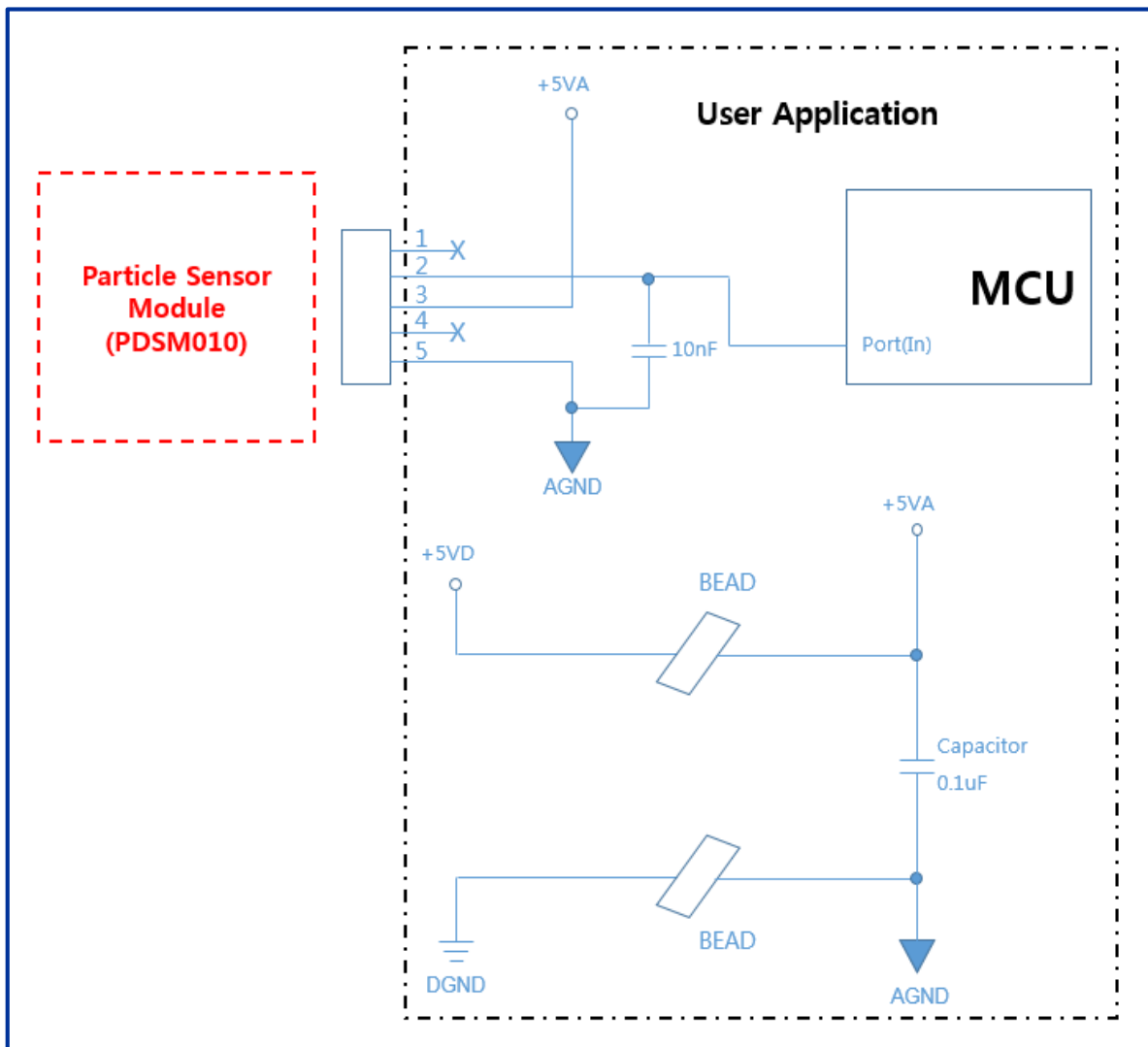

Figure 2 Basic Schematic

** Please use an extra power regulator and/or a bypass capacitor(below 10nF) on the signal line in order to compensate noise if there is noise on the signal or power line and/or signal line are longer than 50cm.

Particle Sensor Characteristics

Low Pulse Ratio and Particle Count (pcs/283mℓ) Correlation

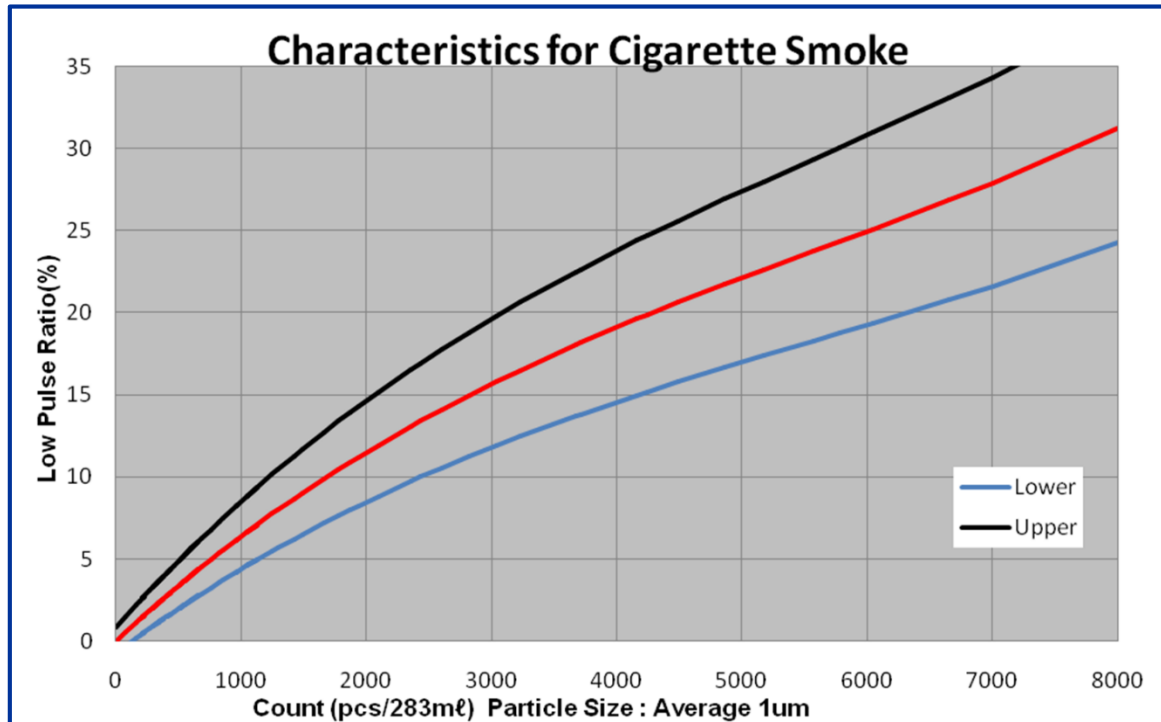

Figure 3 Low Pulse Ratio and Particle Count Correlation Graph

** The sensor's characteristic is verified at the following condition :

Ambient Temperature and humidity of 22±5°C and 30~60%RH in 30m' room chamber.

The reference is located at the center of the room chamber. For more details, please contact SAMYOUNG S&C.

** 283mℓ = 0.01 CF(Cubic Feet).

Particle counters use CFM(cubic feet per minute) for Flow Rate in general and it is converted into Liter on the above graph.

** The particle weight concentration in this datasheet was measured on the basis of the reference and the accuracy of weight concentration solely depends on the reference. Please contact SAMYOUNG S&C for weight concentration conversion.

Low Ratio Calculation

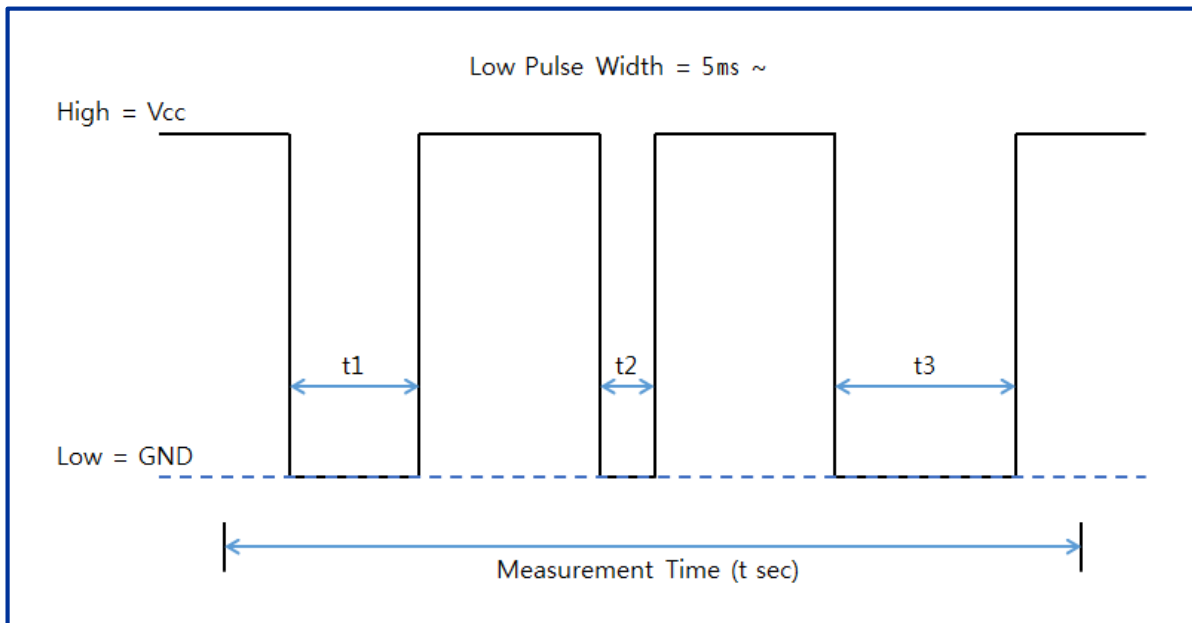

Figure 4 Particle Sensor Low Ratio

$$\text{Low Ratio (\%)} = (t1 + t2 + t3) / t \times 100$$

(Measurement Time is calculated by a percentage of sum of Low signals occurred within t (Approx.60) seconds))

** 60 sec for calculating Low Pulse Ratio is recommended.

If it is shorter than 60 sec, the signal detection becomes too sensitive that may lead to frequent fluctuation.

If it is longer than 60 sec, the signal detection becomes insensitive.

** Checking the changes of Low Pulse Ratio(%) values should be done by 1~2 sec cycle.

If to set other time cycles, please contact SAMYOUNG S&C for an advice.

Dimension

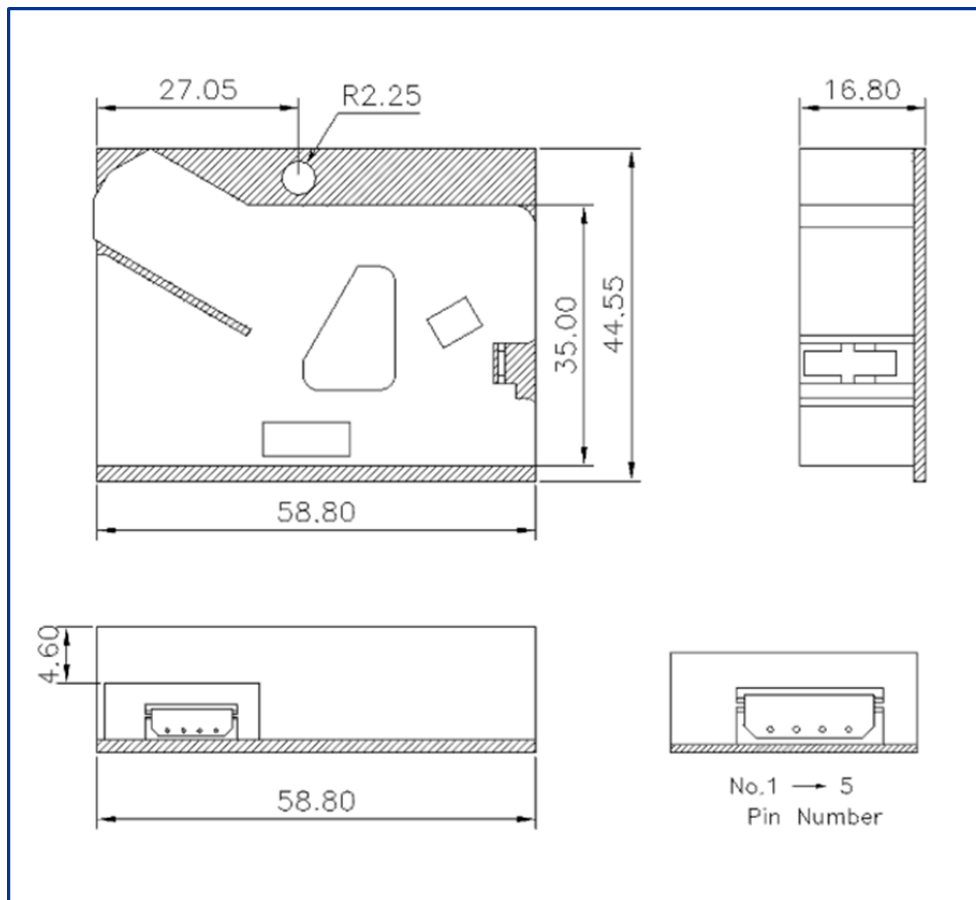

Figure 5 Dimension

Ordering Information

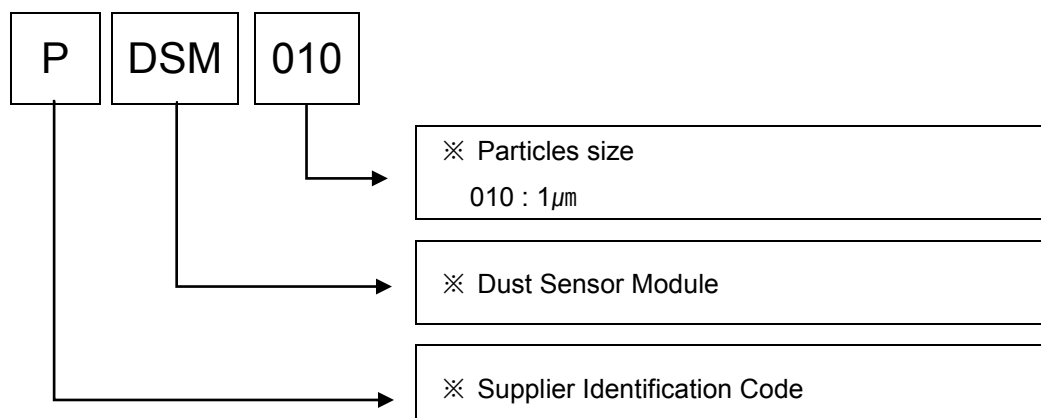
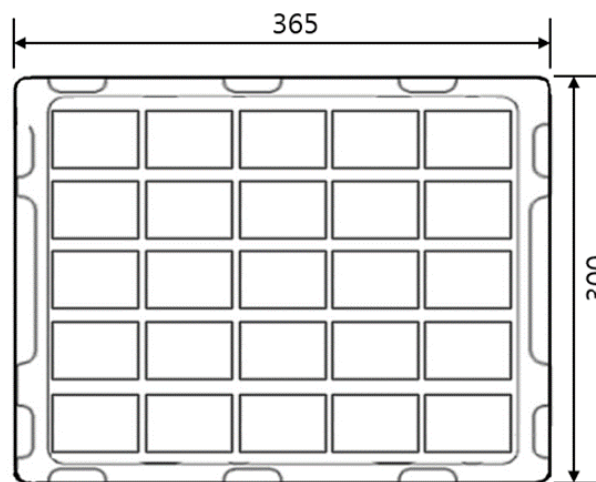

Figure 6 Ordering Information

Packaging Information

Type	Quantity (pcs.)		S i	
	Tray	Out box	Tray	Out box
PDSM010	25EA	250EA	365×300×25	380×320×255

Tray : 25pcs / 1 Tray (PS, 365×300×25mm)



Out box (KBL3SK, 380×320×255mm) : 10 Trays (250pcs)

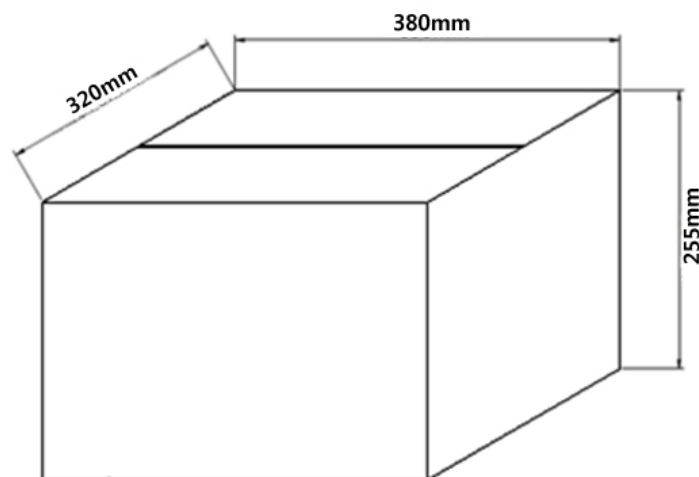

Caution

Please do not adjust, disassemble or reassemble the sensor arbitrarily. It may cause malfunctions of the sensor.

To use the product properly, please refer to the attached additional 'Application Note'.

Please avoid using this sensor for Emergency or Fire alarm application.

Out box label

	PART NO.	Q.TY	PCS.
	PDSM10		250
D .NO.	LOT NO.		
	160101A		
CUSTOMER	CODE NO		
 SAMYOUNG S&C		RoHS Compliant	

Lot No. Year / Month / Date / Measurement Equipment / Chamber

Lot Marking

160101A

160101 : Year / Month / Date
 A : A JIG

Reliability

No	Test Item	Test Condition	Test Criterion
1	Heat Endurance	60°C 1,000 hours	<p>Output < Upper limit +30%</p> <p>Output > Lower limit -30%</p>
2	Cold Endurance	-30°C 500 hours	
3	Heat Cycle	-25°C, 70°C each 30 minutes, Repeat 10 times (Moving time : within 10 sec)	
4	Solder Crack	-40°C, 85°C each 1hour, Repeat 200 times (Moving time : within 10 sec)	
5	High Temperature and Humidity	1,000 hours in the 60°C, 90%~95%R.H.	
6	H2S Endurance	25°C, 95%R.H., H2S 10~15ppm, 240hours	
7	SO2 Endurance	25°C, 95%RH, SO2 10~15ppm, 240hours	
8	High Temperature & Humidity (Supply Voltage)	In the environment at 60°C, 90~95%RH, 1,000 hours, Supply voltage - 5V	
9	On-off Cycle	Leaving sensor at 45°C, 90%~95%RH, 500 hours / On-Off switch for 5V power supply every 5minutes.	
10	Vibration	Amplitude : 1.5mm (X-Y-Z axis), Vibration cycle : 10-55-10Hz for 2hours	
11	Drop	Drop 3 times to woodblock at the height of 70cm	
13	Open-Short	5V power supplying with a short circuit	

Revision History

Date	Version	Page	Change
28 March 2016	1.0		First Release
11 July 2016	1.1	P11, 14	Packaging Specification & BOM Changed
9 Aug 2016	1.2	P2, P3, P4, P5, P6	Product Summary Revised, Product Specification Revised Internal Configuration Revised I/O Connector Specifications Revised Pin Description Revised Basic Circuit Diagram Revised Description of Optimization Function Removed
12 Oct 2016	1.3	P3	Life Expectancy
18 Apr 2018	1.4	P2	Accuracy Tolerance Removed
30 Apr 2018	1.5	P1	Feature Revised
		P1,2,3,4	Term Changed (PWM → LPO)
		All	Edit Total Page 14 → 13
2 May 2018	1.6	P5	10uH BEAD → BEAD Changed



This publication is the proprietary product of SAMYOUNG S&C and is copyrighted, with all rights reserved. Under the copyright laws, no part of this publication may be reproduced or transmitted in any form or by any means, electronic or mechanical, for any purpose, in whole or in part, without the express written permission of SAMYOUNG S&C. Express written permission is also required before a third party may make any use of this publication.

SAMYOUNG S&C Co., Ltd.

446, Dunchon-daero, Jungwon-gu,
Seongnam-city, Gyeonggi-do,
KOREA 13229

Phone : +82-31-741-1830

Fax : +82-31-741-1821

e-mail : sales@samyoungsnc.com

Homepage : www.samyoungsnc.com

This Application Guide should be used only for intended and authorized application of **PDSM010**. Please consult with **SAMYOUNG S&C** for any specific application requirements and for detailed data sheet.

Copyright 2018©, **SAMYOUNG S&C**