

# SPECIFICATION FOR APPROVAL

CUSTOMER	_____
CUST. PART NO.	_____
CUST. DOC. REV.	_____
DESCRIPTION	SMD CHIP BEAD(RoHS+H.F.)
SAMPLE LOT NO.	_____
PART NO.	TI201212F102-LRH
DOC. REV.	ORIG
DATE	_____

Once you approve this part, please sign and return this page to the following marked location.

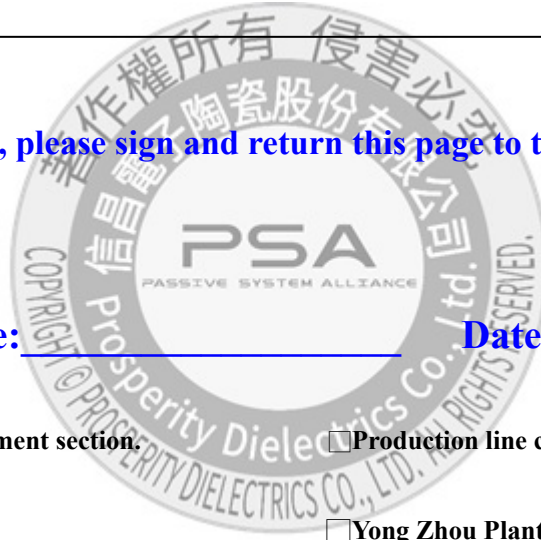

**Customer Signature:** \_\_\_\_\_ **Date:** \_\_\_\_\_

This part currently development section.  Production line can produce this series of products.

Sales Office-Headquarter  
No. 566-1, Kao-Shi Rd., Yangmei, Taoyuan 32668,  
Taiwan  
TEL: +886-3-475-3355  
FAX: +886-3-485-4959

Yong Zhou Plant  
Tao-Yuan Rd., Fenghuang Park, Lengshuitan  
District, Yongzhou, Hunan 425000, P.R.C.  
TEL: +86-746-8610-180  
FAX: +86-746-8610-181

Sales Office-Dong Guan,China  
No.638,Mei Jing West Road Xiniupo Administrative  
Zone Dalang Town,Dong Guan City,GuangDong  
Province,China.  
TEL: +86-769-8555-0979  
FAX: +86-769-8555-0972

TESTED BY	CHECKED BY	APPROVED BY

# TABLE OF CONTENTS

INDEX	Page
■ Engineering Change Notice - Record .....	2
■ Part Number Identification .....	3
■ Mechanical Dimension .....	3
■ Electrical Specification .....	3
■ Electrical Curve .....	3
■ Reliability Performance .....	4
■ Reflow Chart .....	5
■ Packing .....	6
■ Test Report .....	

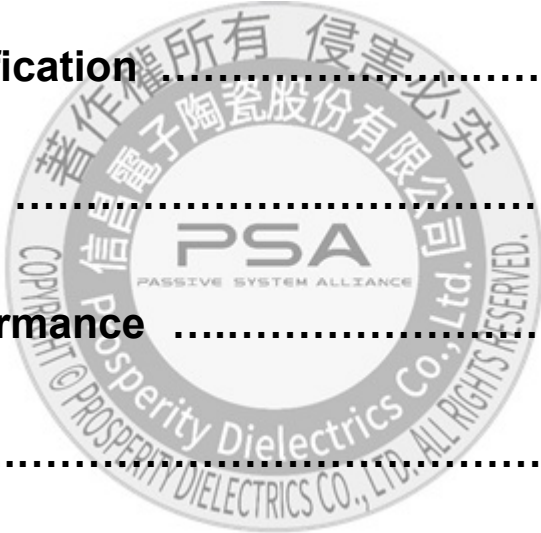

# SPECIFICATION FOR APPROVAL

CUSTOMER	CUSTOMER P/N	REV. -	SPL. LOT NO.	
PART NAME <b>SMD CHIP BEAD (RoHS+H.F.)</b>	PART NO. <b>TI201212F102-LRH</b>	REV. <b>ORIG</b>	DATE OF ISSUE	Q'TY <b>0 PCS</b>

## ENGINEERING CHANGE NOTICE - RECORD

REVISION NO.	REVISION DESCRIPTION	AUTHOR	DATE	REMARK
<b>ORIG</b>		<i>Bruce Hsu</i>		



# SPECIFICATION FOR APPROVAL

※This is a RoHS and REACH compliant product whose related documents are available on request.  
 ※Graphic is only for dimensionally application.

## 1. PART NUMBER IDENTIFICATION

**TI 201212 F □□□ - LRH**

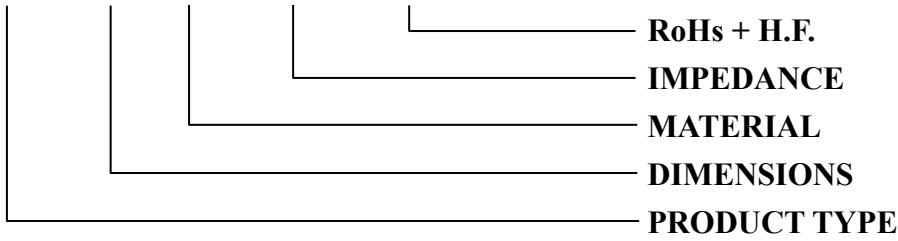

## 2. MECHANICAL DIMENSION

UNIT: mm

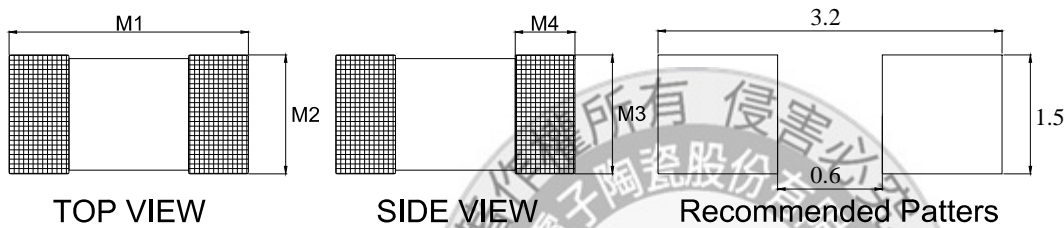

	DIM.	TOL.
M1	2.00	±0.20
M2	1.25	±0.20
M3	1.25	±0.20
M4	0.50	±0.30

## 3. ELECTRICAL SPECIFICATION

Part number	Impedance (Ω) ±25%	Test Frequency (MHz)	DC Resistance (Ω) MAX.	Rated Current (mA)
TI201212F102-LRH	1000	100	0.09	2000

TEST INSTRUMENT: HP4291B、HP4338A/B、HP6632B、Agilent 8720ES

TEST LEVEL: 250 mV

## 4. ELECTRICAL CURVE

TI201212F102-LRH

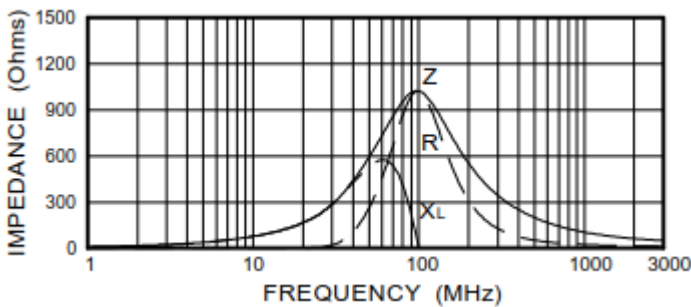

# SPECIFICATION FOR APPROVAL

## 5. RELIABILITY PERFORMANCE

Test Item	Test Condition	Criteria
Temperature Cycle	a. Temperature : -40 ~ +85°C b. Cycle : 100 cycles c. Dwell time : 30 minutes d. Measurement : at ambient temperature 24 hrs after test completion	a. No mechanical damage b. Impedance value should be within ±20% of the initial value
Operational Life	a. Temperature : 125°C±5°C b. Test time : 1000 hrs c. Apply current : full rated current d. Measurement : at ambient temperature 24 hrs after test completion	a. No mechanical damage b. Impedance value should be within ±20% of the initial value
Biased Humidity	a. Temperature : 40°C±2°C b. Humidity : 90 ~ 95 % RH c. Test time : 1000 hrs d. Apply current : full rated current e. Measurement : at ambient temperature 24 hrs after test completion	a. No mechanical damage b. Impedance value should be within ±20% of the initial value
Resistance to Solder Heat	a. Solder temperature : 260±5°C b. Flux : Rosin c. DIP time : 10±1 sec	a. More than 95% of terminal electrode should be covered with new solder b. No mechanical damage c. Impedance value should be within ±20% of the initial value
Adhesive Test	a. Reflow temperature : 245°C It shall be Soldered on the substrate applying direction parallel to the substrate b. Apply force(F) : 5 N c. Test time : 10 sec	a. No mechanical damage b. Soldering the products on PCB after the pulling test force > 5 N
Steam Aging Test	a. Temperature : 93°C b. Test time : 4 hrs (MCB1005) Others : 8 hrs c. Solder temperature : 235±5°C d. Flux : Rosin e. DIP time : 5±1 sec	More than 95% of terminal electrode should be covered with new solder
Rated Current Test	a. Apply current : full rated current / 5min	Temperature rise should be less than 40°C

**OPERATING TEMPERATURE RANGE : - 55°C ~ +125°C**

**STORAGE CONDITION : LESS THAN 40°C & 70% RH**

# SPECIFICATION FOR APPROVAL

## 6. TYPICAL RoHS REFLOW PROFILE

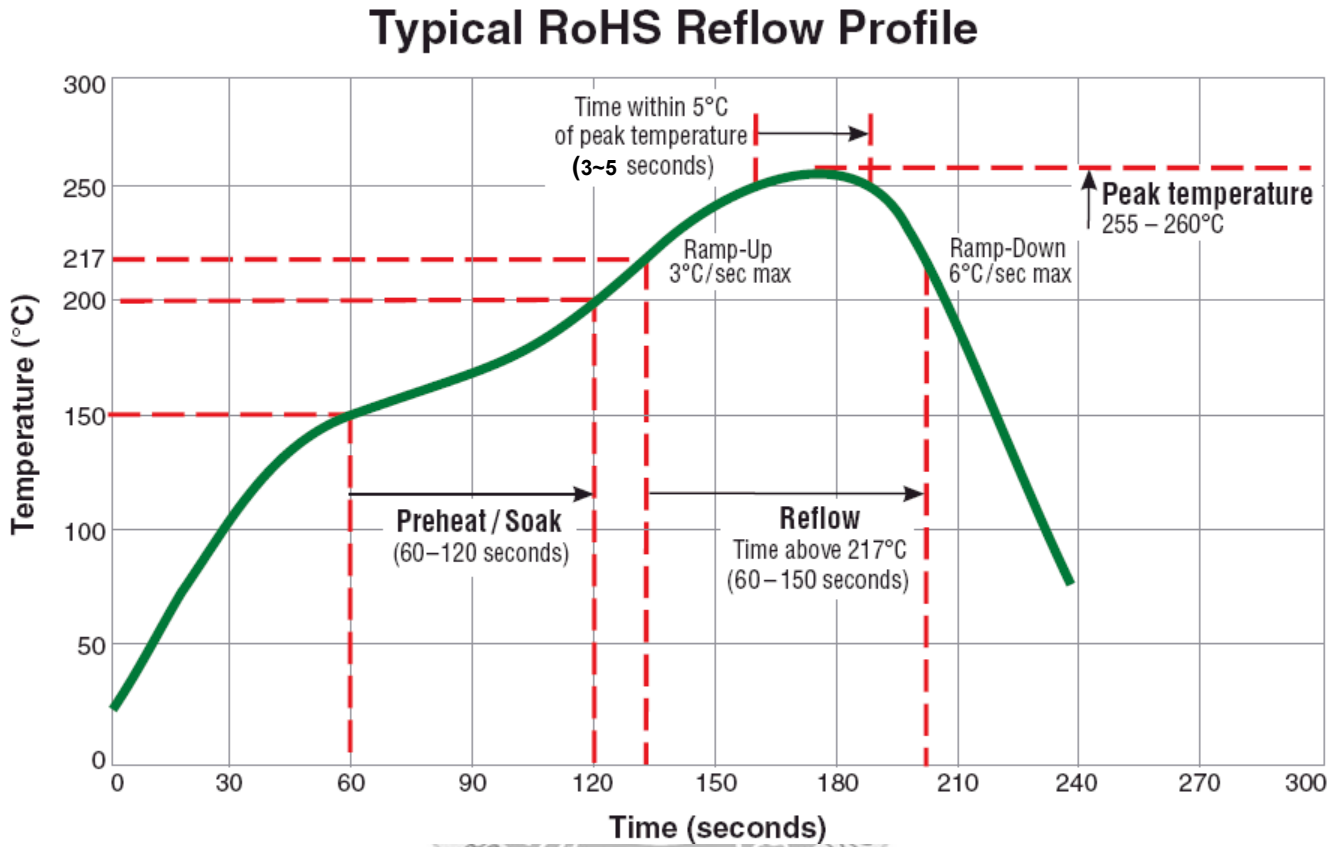

# SPECIFICATION FOR APPROVAL

## 7. PACKING

### 7.1 PLASTIC CARRIER

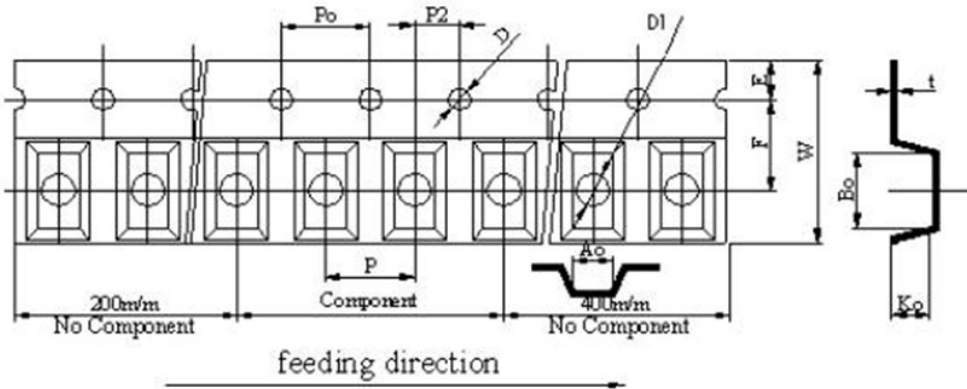

UNIT : mm

W	P	E	F	D	D1	Po	P2	Ao	Bo	Ko	t
7.90~8.30	4.00±0.10	1.75±0.10	3.50±0.05	1.50±0.05	0.95~1.20	4.00±0.10	2.00±0.05	1.42±0.10	2.26±0.10	1.30±0.10	0.23±0.10

### 7.2 REEL DIMENSIONS

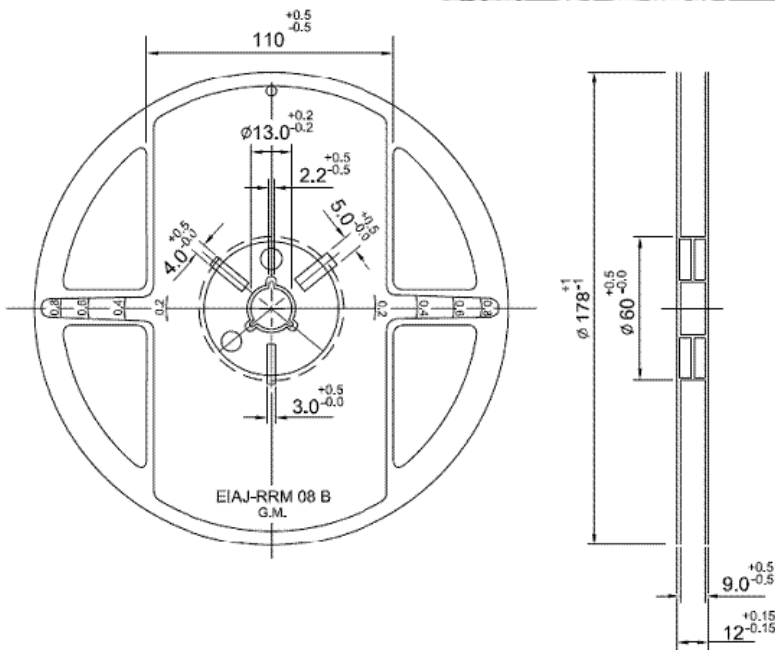

### 7.3 Packaging Quantity

Reel	Inner Box
3,000 Pcs	5 Reels