

SPECIFICATION FOR APPROVAL

CUSTOMER	_____
CUST. PART NO.	_____
CUST. DOC. REV.	_____
DESCRIPTION	CHIP INDUCTORS(RoHS+H.F.)
SAMPLE LOT NO.	_____
PART NO.	ML160808H-XXXX-LRH
DOC. REV.	ORIG
DATE	_____

Once you approve this part, please sign and return this page to the following marked location.

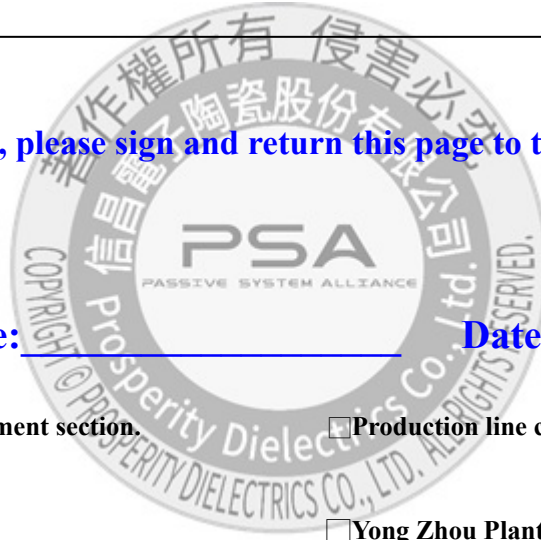

Customer Signature: _____ Date: _____

This part currently development section. Production line can produce this series of products.

Sales Office-Headquarter

No. 566-1, Kao-Shi Rd., Yangmei, Taoyuan 32668,
Taiwan
TEL: +886-3-475-3355
FAX: +886-3-485-4959

Yong Zhou Plant

Tao-Yuan Rd., Fenghuang Park, Lengshuitan
District, Yongzhou, Hunan 425000, P.R.C.
TEL: +86-746-8610-180
FAX: +86-746-8610-181

Sales Office-Dong Guan,China

No.638,Mei Jing West Road Xiniupo Administrative
Zone Dalang Town,Dong Guan City,GuangDong
Province,China.
TEL: +86-769-8555-0979
FAX: +86-769-8555-0972

TESTED BY	CHECKED BY	APPROVED BY

TABLE OF CONTENTS

INDEX	Page
■ Engineering Change Notice - Record	2
■ Part Number Identification	3
■ Mechanical Dimension	3
■ Electrical Specification	3 ~ 4
■ Electrical Curve	4
■ Reliability Performance	5
■ Reflow Chart	6
■ Packing	7 ~ 8
■ Test Report	

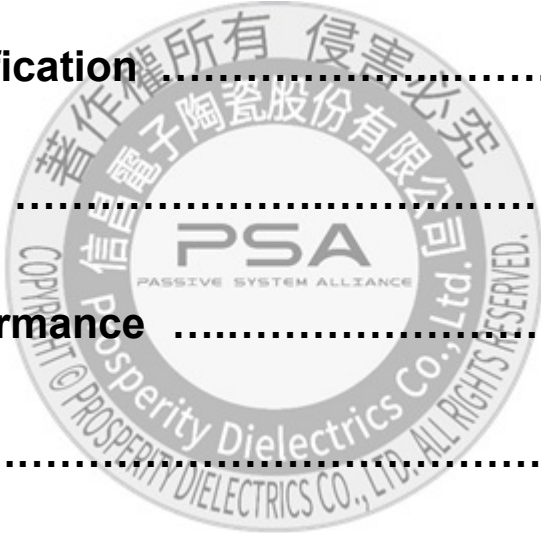

SPECIFICATION FOR APPROVAL

CUSTOMER	CUSTOMER P/N	REV. -	SPL. LOT NO.	
PART NAME CHIP INDUCTORS (RoHS+H.F.)	PART NO. ML160808H-XXXX-LRH	REV. ORIG	DATE OF ISSUE	Q'TY 0 PCS

ENGINEERING CHANGE NOTICE - RECORD

REVISION NO.	REVISION DESCRIPTION	AUTHOR	DATE	REMARK
ORIG		<i>Bruce Hsu</i>		



SPECIFICATION FOR APPROVAL

※This is a RoHS and REACH compliant product whose related documents are available on request.
 ※Graphic is only for dimensionally application.

1. PART NUMBER IDENTIFICATION

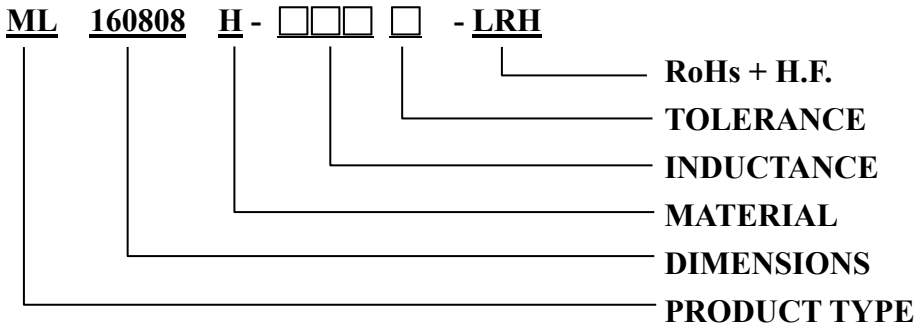

2. MECHANICAL DIMENSION

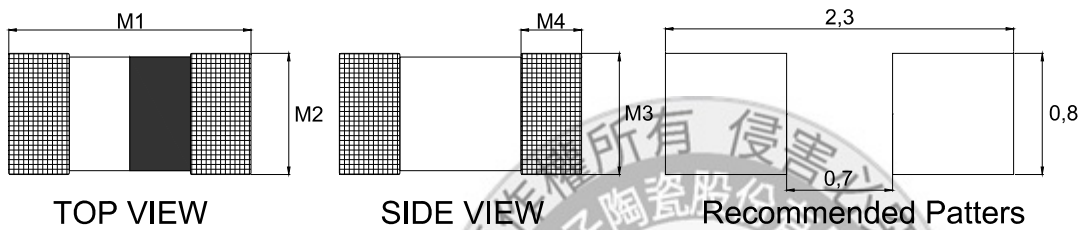

	DIM.	TOL.
M1	1.6	±0.15
M2	0.8	±0.15
M3	0.8	±0.15
M4	0.4	±0.20

3. ELECTRICAL SPECIFICATION

Part number	Inductance (nH)	Inductance Tolerance	Q MIN.	L,Q Test Frequency (MHz)	SRF (MHz) MIN.	DC Resistance (Ω) MAX.	Irms (mA) MAX.
ML160808H-1N0□-LRH	1.0	S	8	100	10000	0.05	1000
ML160808H-1N2□-LRH	1.2	S	8	100	10000	0.05	1000
ML160808H-1N5□-LRH	1.5	S	8	100	10000	0.10	1000
ML160808H-1N8□-LRH	1.8	S	8	100	10000	0.10	1000
ML160808H-2N2□-LRH	2.2	S	8	100	8000	0.10	1000
ML160808H-2N7□-LRH	2.7	S	10	100	7000	0.13	1000
ML160808H-3N3□-LRH	3.3	S	10	100	6000	0.13	1000
ML160808H-3N9□-LRH	3.9	S	10	100	6000	0.15	1000
ML160808H-4N7□-LRH	4.7	S	10	100	5000	0.20	1000
ML160808H-5N6□-LRH	5.6	S	10	100	4000	0.23	600
ML160808H-6N8□-LRH	6.8	J	10	100	4000	0.25	600
ML160808H-8N2□-LRH	8.2	J	10	100	3500	0.28	600
ML160808H-10N□-LRH	10	J	12	100	3400	0.30	600
ML160808H-12N□-LRH	12	J	12	100	2600	0.35	600
ML160808H-15N□-LRH	15	J	12	100	2300	0.40	600
ML160808H-18N□-LRH	18	J	12	100	2000	0.45	600
ML160808H-22N□-LRH	22	J	12	100	1600	0.50	600
ML160808H-27N□-LRH	27	J	12	100	1400	0.55	600
ML160808H-33N□-LRH	33	J	12	100	1200	0.60	600
ML160808H-39N□-LRH	39	J	12	100	1100	0.65	500
ML160808H-47N□-LRH	47	J	12	100	900	0.70	500

SPECIFICATION FOR APPROVAL

Part number	Inductance (nH)	Inductance Tolerance	Q MIN.	L,Q Test Frequency (MHz)	SRF (MHz) MIN.	DC Resistance (Ω) MAX.	Irms (mA) MAX.
ML160808H-56N□-LRH	56	J	12	100	900	0.75	500
ML160808H-68N□-LRH	68	J	12	100	700	0.85	400
ML160808H-82N□-LRH	82	J	12	100	600	0.95	300
ML160808H-R10□-LRH	100	J	12	100	600	1.00	300
ML160808H-R12□-LRH	120	J	8	50	500	1.20	300
ML160808H-R15□-LRH	150	J	8	50	500	1.20	300
ML160808H-R18□-LRH	180	J	8	50	400	1.30	300
ML160808H-R22□-LRH	220	J	8	50	400	1.50	300
ML160808H-R27□-LRH	270	J	8	50	400	1.90	200
ML160808H-R33□-LRH	330	J	8	50	350	2.10	200
ML160808H-R39□-LRH	390	J	8	50	350	2.30	150
ML160808H-R47□-LRH	470	J	8	50	300	2.60	150

TEST INSTRUMENT: Agilent E4991A+16192A、Agilent 4338B

□Tolerance: S=±0.3nH/J=±5%

※Irms: Full rated current 5min,temperature rise should be less than 25°C.

※MSL: LEVEL 1

4. ELCTRICAL CURVE

L vs. Frequency
ML160808H Series

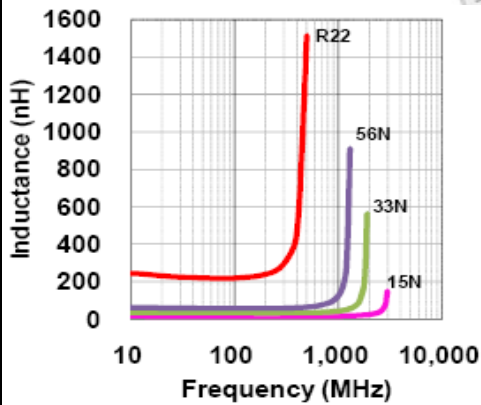

Q vs. Frequency
ML160808H Series

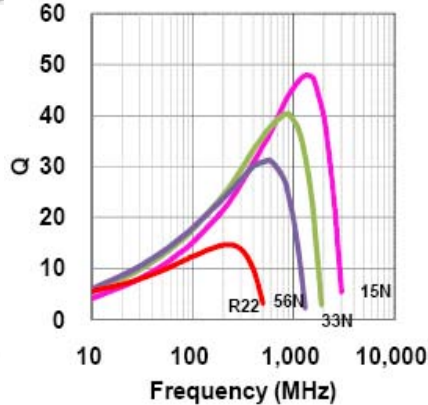

Z vs. Frequency
ML160808H Series

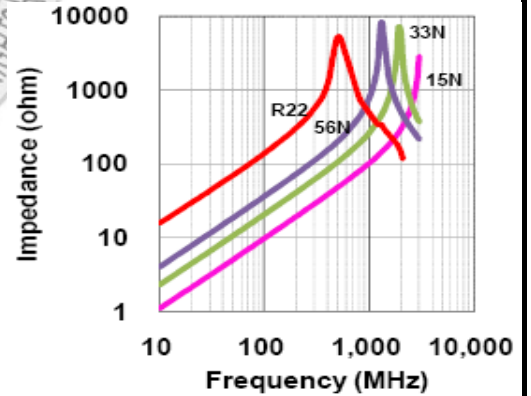

SPECIFICATION FOR APPROVAL

5. RELIABILITY PERFORMANCE

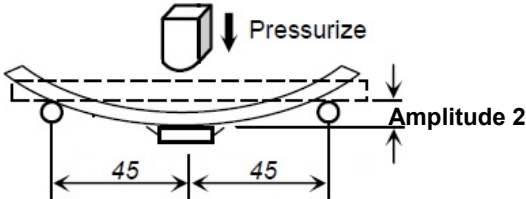
Item	Test Condition	Standard Source
Temperature Cycle	1. Temperature : $-55 \sim +125^{\circ}\text{C}$ 2. Cycle : 100 cycles 3. Dwell time : 30 minutes 4. Measurement : at ambient temperature 24 hrs after test completion	1. No mechanical damage 2. Inductance value should be within $\pm 10\%$ of the initial value 3. Q vale should be within $\pm 20\%$ of the initial value
Operational Life	1. Temperature: $85 \pm 5^{\circ}\text{C}$ 2. Testing time: 1000 hrs 3. Applied current : Full rated current 4. Measurement: At ambient temperature 24 hours after test completion	1. No mechanical damage 2. Inductance value should be within $\pm 10\%$ of the initial value 3. Q vale should be within $\pm 20\%$ of the initial value
Biased Humidity	1. Temperature : $40^{\circ}\text{C} \pm 2^{\circ}\text{C}$ 2. Humidity : 90 ~95% RH 3. Test time : 1000 hrs 4. Apply current : full rated current 5. Measurement : at ambient temperature 24 hrs after test completion	1. No mechanical damage 2. Inductance value should be within $\pm 10\%$ of the initial value 3. Q vale should be within $\pm 20\%$ of the initial value
Resistance to Solder Heat	1. Solder temperature : $260 \pm 5^{\circ}\text{C}$ 2. Flux : Rosin 3. DIP time : 10 ± 1 sec	1. More than 95% of terminal electrode should be covered with new solder 2. Inductance value should be within $\pm 10\%$ of the initial value 3. Q vale should be within $\pm 20\%$ of the initial value
Solderability	1. Solder temperature : $235 \pm 5^{\circ}\text{C}$ 2. Flux : Rosin 3. DIP time : 5 ± 1 sec	1. More than 95% of terminal electrode should be covered with new solder 2. No mechanical damage
Bending Strength	1. Solder the chip to test jig then apply a force in the direction shown in below. 2. The soldering shall be done with the reflow method and shall be conducted with care so that the soldering is uniform and free of defects such as heat shock. 	No mechanical damage

SPECIFICATION FOR APPROVAL

6. TYPICAL RoHS REFLOW PROFILE

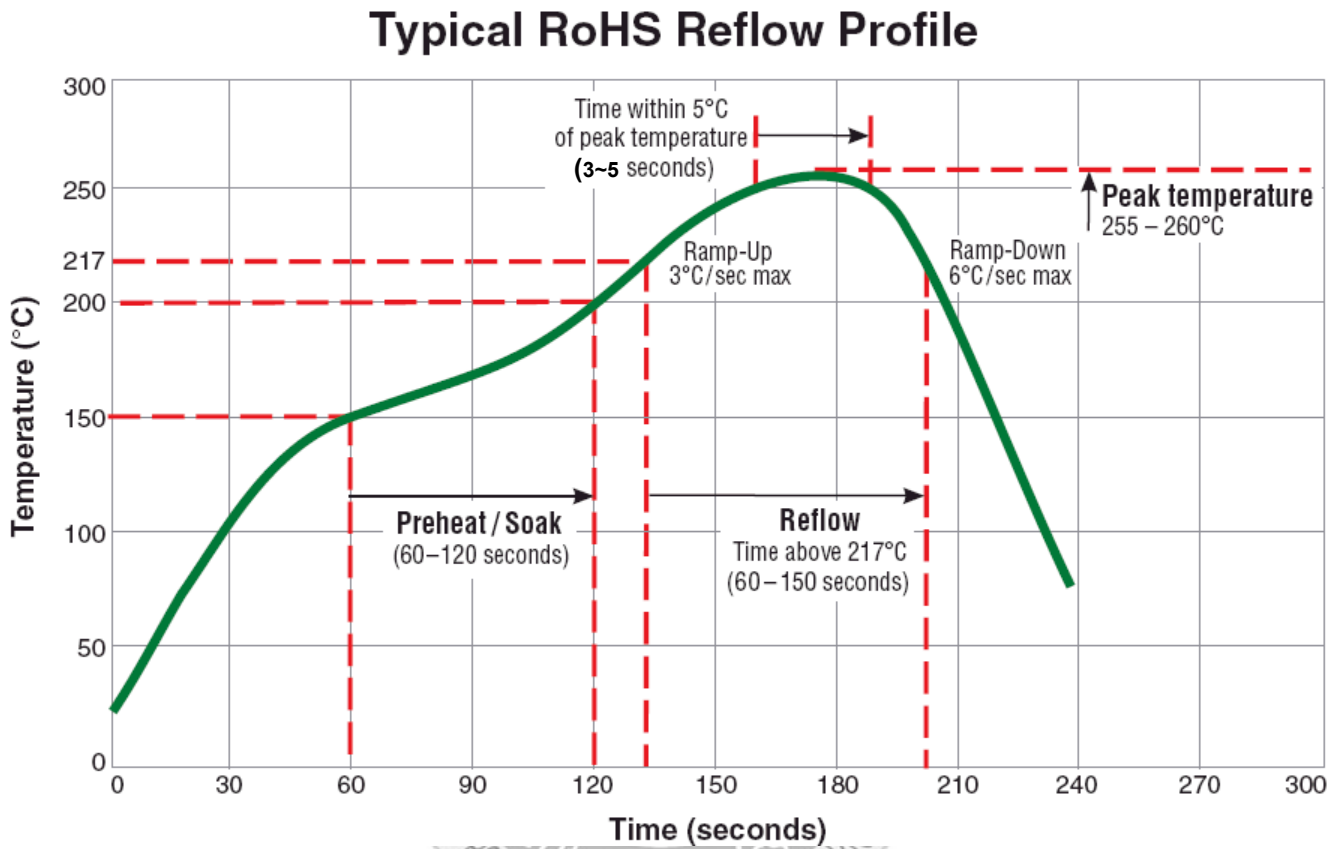

SPECIFICATION FOR APPROVAL

7. PACKING

7.1 Leader and Trailer Tape

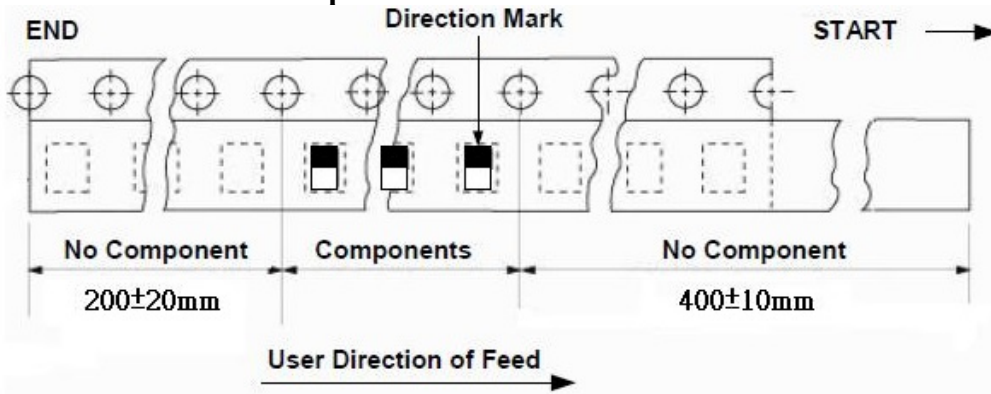

7.2 Peel-off force

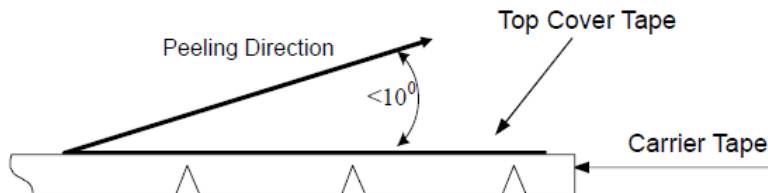

Peel-off force should be in the range of 10~50g at a peel-off of 300mm/min

7.3 Dimensions

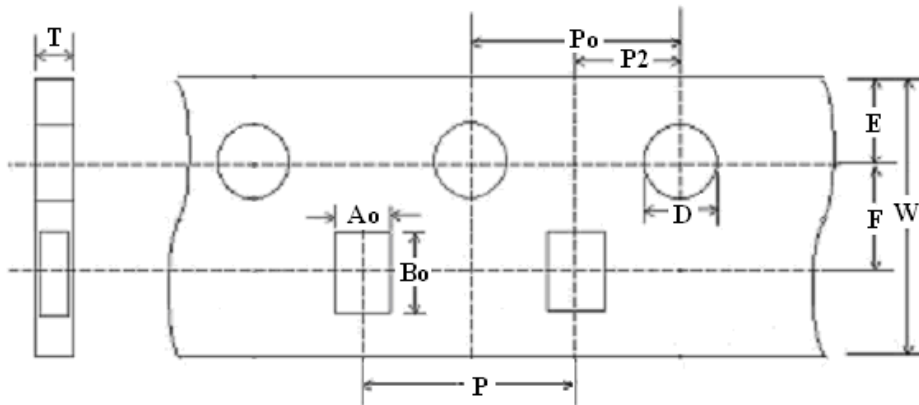

UNIT : mm

W	P	E	F	D	Po	P2	Ao	Bo	T
8.00 ± 0.10	4.00 ± 0.10	1.75 ± 0.05	3.50 ± 0.05	1.55 ± 0.05	4.00 ± 0.10	2.00 ± 0.05	0.98 ± 0.03	1.80 ± 0.05	0.95 ± 0.05

SPECIFICATION FOR APPROVAL

7.4 Reels

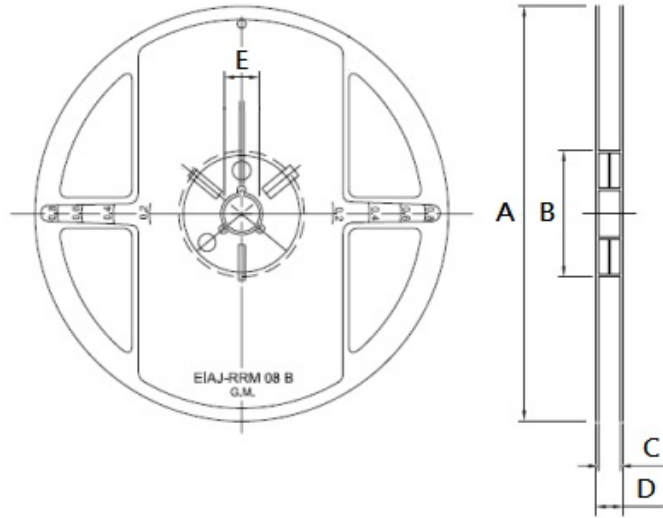

UNIT : mm

A	B	C	D	E
178±1.0	60±0.5	9.0±0.5	12±0.15	13.0±0.2

7.5 Packaging Quantity

Reel	Inner Box
4000 Pcs	5 Reels

