

## KNC label plate

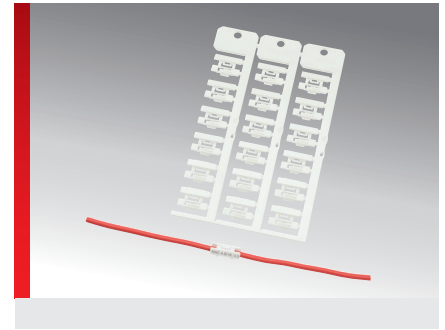
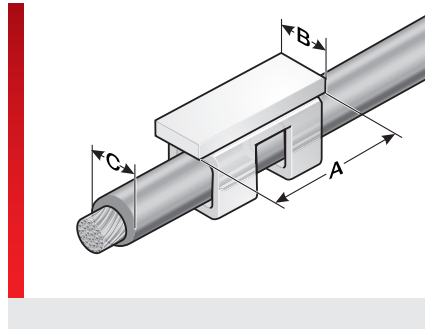

Single wire, cable, and conduit labelling

### PRODUCT INFORMATION

High-quality, halogen-free label for subsequent direct labelling of wires. The KNC is made of PC material and has been developed for direct and subsequent marking of cables and wires. No tools required.

7,2 mm.

Available in four sizes for diameter of 2,0 –

### SPECIFICATIONS

- Polycarbonate (PC)
- 40 – 130 °C
- V0

**HF**

Type	Order No.	Colour	Application range from - to Ø mm (C)	Label size mm (B x A)	Title space mm	No. characters/lines	No. per Frame	Base plate	Software Type	Pack qty.
<b>For cable diameters of 2.0 mm to 3.1 mm</b>										
KNC 4,0/18-2,0	86381914	White	2.00 – 3.10	4.00 x 18.00	4.00 x 18.00	10 / 1	18	GP3C	C02	234

### MATERIAL PROPERTIES

Polycarbonate (PC)

### THERMAL PROPERTIES

**Temperature / temperature range**  
-40 – 130 °C

### FIRE BEHAVIOUR

**Fire classification**  
V0

### TECHNICAL INFORMATION

**HF** Halogen-free  
DIN/VDE 0472, Part 815

### INSTALLATION METHOD

**Clamping system**

## KNC label plate

### LABELLING TECHNOLOGY



Plotter



Laser devices



Inkjet

All details given in our sales brochures and catalogues, as well as the information available online, are based on our current knowledge of the products described.

The electronic data and files made available by Murrplastik, particularly CAD files are based on our current knowledge of the product described.

A legally binding assurance of certain properties or the suitability for a certain purpose can not be determined from this information.

All information with respect to the chemical and physical properties of Murrplastik products, as well as application advice given verbally, in writing or by tests, is given to the best of our knowledge.

This does not free the purchaser of carrying out their own inspections and tests in order to determine the suitability of a product for a specific purpose.

Murrplastik accepts no responsibility for the available information being up-to-date, correct or complete. Neither do we accept responsibility for the quality of this information.

Murrplastik accepts no liability for damage caused as a result of using our products.

Murrplastik reserves the right to make technical changes and improvements through constant further development of products and services.

Our General Terms and Conditions apply.