



TO :  
\_\_\_\_\_

**HUMIDITY SENSOR**

**P/N : SYH-2R\_\_ .I**

**[ INDUSTRIAL VERSION ]**

-----  
**SPECIFICATIONS**  
-----



## 1. Scope of application

This specification is applicable to the resistive type humidity sensor SYH-2R (Industrial Version)

## 2. Type

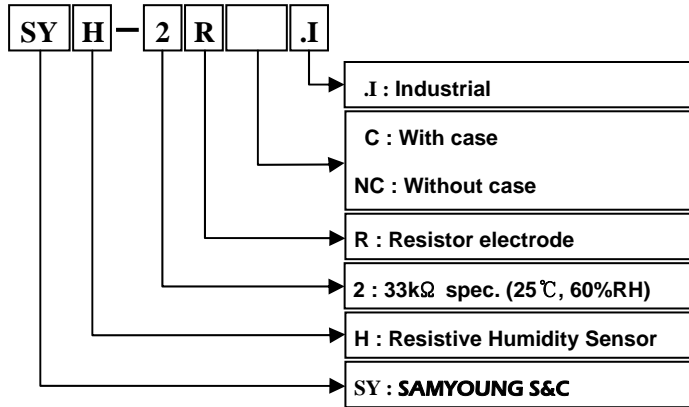

2-1. SYH-2RC.I : Humidity sensor unit with Case

2-2. SYH-2RNC.I : Humidity sensor unit (No Case)

## 3. Configuration

The configuration of the humidity sensor unit is shown on the [Fig.1](#).

## 4. Electrical characteristics

4-1. Rated voltage	: MAX. AC 5Vpp (recommended 1V <sub>RMS</sub> )	
4-2. Rated power	: 0.26mW (at 1V <sub>RMS</sub> )	
4-3. Standard characteristic	: 33kΩ (at 25°C, 60%RH, 1V <sub>RMS</sub> , 1kHz)	<a href="#">[Fig. 2]</a>
4-4. Operating temperature	: -20°C ~ 85°C	<a href="#">[Fig. 3]</a>
4-5. Operating humidity range	: 10 ~ 95%RH (non-condensing)	
4-6. Operating frequency range	: 100Hz ~ 10kHz	<a href="#">[Fig. 4]</a>
4-7. Storage temperature range	: -30°C ~ 85°C	
4-8. Storage humidity range	: Less than 95%RH (non-condensing)	
4-9. Accuracy	: ±3%RH (at 25°C, 60%RH)	
4-10. Hysteresis	: Within 2%RH (at 25°C, 40⇔80%RH)	
4-11. Response time	: < 45 sec. (30⇔90%RH), T80)	
4-12. Temperature coefficient	: - 0.5%RH / °C	

## 5. Reliability

No	Test Item	Test Condition	Test Criterion
1	High Temperature Storage	- Temperature: 85℃ Test time: 1,000 hours Recovery time : 1 ~ 2 hours	< ± 5%RH
2	Low Temperature Storage	- Temperature:- 30℃ Test time: 1,000 hours. Recovery time : 1 ~ 2 hours	< ± 5%RH
3	High Temperature/High Humidity Loading	- Temperature: 40℃, Humidity : 95 %RH Test time : 1000 hours, Bias : 1V <sub>pp</sub> , 1kHz Recovery time : 1 ~ 2 hours	< ± 5%RH
4	Humidity cycle	- Temperature : 25 ℃, Cycle : 500 times Humidity : 30(30min)↔90(30min) %RH Recovery time : 1 ~ 2 hours	< ± 5%RH
5	Temperature cycle (Thermal-shock test)	-Temperature:-30℃(30min)↔85℃(30min) Cycle : 100 times Recovery time : 1 ~ 2 hours	< ± 5%RH
6	Organic solvent resistance	- Benzene 30wt.%+ Xylene 40wt.% + Toluene 30wt.%. Temperature: 25℃, Test time : 300 hours Recovery time : 1 ~ 2 hours	< ± 5%RH
7	Voltage resistance	- Impress 1V <sub>RMS</sub> , 1kHz Test time: 3,000 hrs. Recovery time : 1 ~ 2 hours	< ± 5%RH

## 6. Mechanical characteristics

### 6-1. Shock resistance

Not to be abnormal in the appearance and electrical characteristics after having been dropped down 3 times at random onto a hard wooden plate from the height of 100cm.

### 6-2. Vibration resistance

Not to be abnormal in the appearance and electrical characteristics after the vibration-test for 2 hours each in the directions of X-Y-Z, at the frequency of 10~55Hz, and amplitude of 1.5mm (10-55-10).

### 6-3. Resistance to soldering heat

Not to be abnormal in the appearance and electrical characteristics after the lead terminal is immersed down by 3mm from the substrate for 3 seconds in a solder bath of 260±5℃.

6-4. Strength of terminations (tensile)

Lead terminal shall be secured with the substrate after it shall be pulled with the specified force of 500g for 10 seconds in the axial direction of the lead terminal.

**7. Packaging :** [Fig. 5.]

- 7-1. 50pcs of sensor unit to be packed in a tray (PET, **SYH-2R**)
- 7-2. 20 sheet (1000pcs of sensor unit) to be packed in a shipping carton box  
(**SYH-2R**, size : 200×145×75mm)
- 7-3. 100pcs of sensor unit to be packed in a vinyl pack (**SYH-2R C**)
- 7-4. 10 set (1000pcs of sensor unit) to be packed in a shipping carton box  
(**SYH-2R C**, size : 280×280×55mm)

**8. Basic circuits (example)**

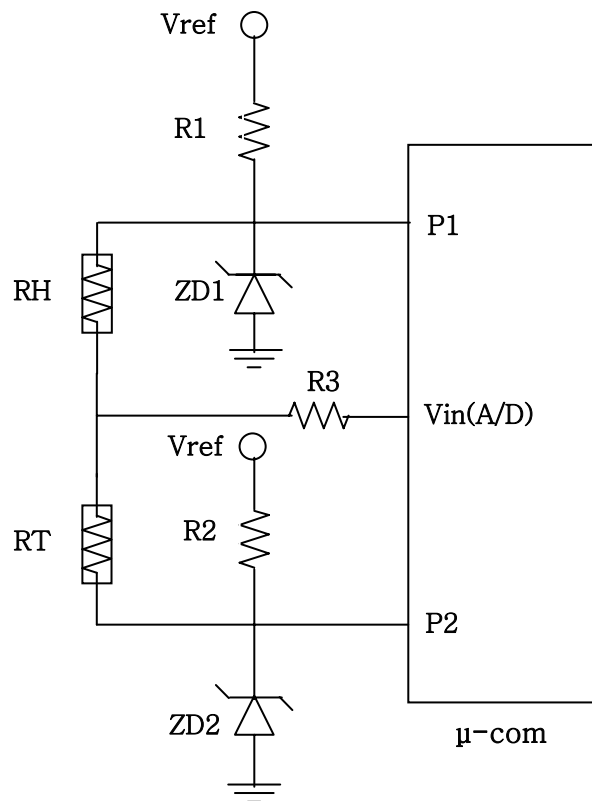

Positive Output :  $V_{in} = RT / (RT + RH) * V_{zd}$

Negative Output :  $V_{in} = RH / (RH + RT) * V_{zd}$

Zener Diode ZD1, ZD2 : 2.2V to 4.7V

RH : Humidity Sensor(SYH-1 or SYH-2 series)

RT :  $R(25^{\circ}C) = 50k\Omega$ ,  $B(25/85^{\circ}C) = 4600$

## 9. Measuring systems

LCR meter:	HIOKI 3532-50
Chamber:	Rotronics humidity generator (Accuracy:±1.0%RH)
Hygrometer:	E+ E EE31

## 10. Application Note

### 10-1. DC voltage

If DC voltage is applied to the humidity sensor, **the migration phenomenon** may be occurred in polymer of the sensor. This migration can effect the resistance characteristics change and may cause of short circuit (polarization phenomenon).

### 10-2. Water condensing

If there is a **condensation on the humidity sensor surface** over 6 hrs, the polymer of the sensor (humidity sensitive) membrane can be diluted by the condensation. It may cause resistance characteristics change.

### 10-3. Drenching (solvent .. etc.)

If the humidity sensor is **soaked in the liquid material** (solvent .. etc) over 30 min, the polymer of the sensor (humidity sensitive) membrane can be melt by the solvent. It may cause resistance characteristics change.

### 10-4. Ionic atmosphere

SYH series humidity sensor is made by using ionic polymer membrane. Therefore if the humidity sensor is exposed **ionic atmosphere** (salty air, anionic ionizer.. etc) for long period of time, the resistance characteristics may change.

### 10-5. Organic / Inorganic gas

If the humidity sensor is exposed directly to **organic / inorganic gases** (i.e. SOx, NOx, Ammonia, Alcohol, Glycol .. etc.) for long period of time, reactive polymer membrane can be damaged and the resistance characteristics may change.

### 10-6. Breakdown / Scratch / Membrane touching

If there are physical external pressure on the sensor such as **breakdown of sensor substrate, sensor scratch, touching sensor membrane**, the sensor (humidity sensitive) membrane and electrode will be damaged. It can cause resistance quality defective.

### 10-7. Heating stress (thermal shock)

In relation to **heating stress**, take extra caution using in the atmosphere of the below

- 1) Using the humidity sensor at over the operating range temperature
- 2) Failed circuit design
- 3) PCB soldering process

**Fig. 1.** Standard Dimension SYH-2R\_I series

(unit : mm)

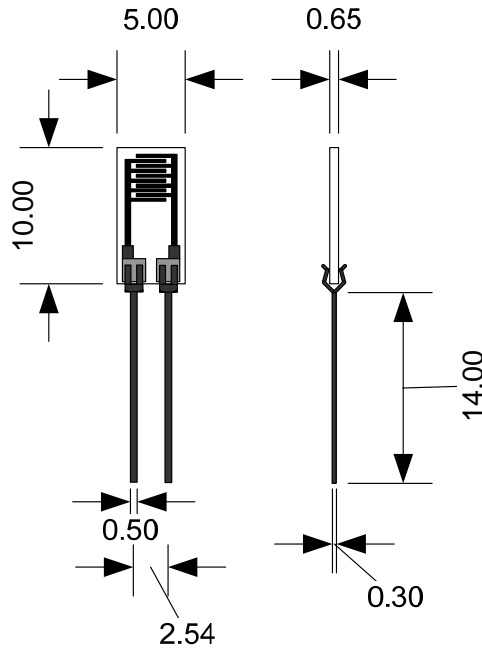

< SYH-2R >

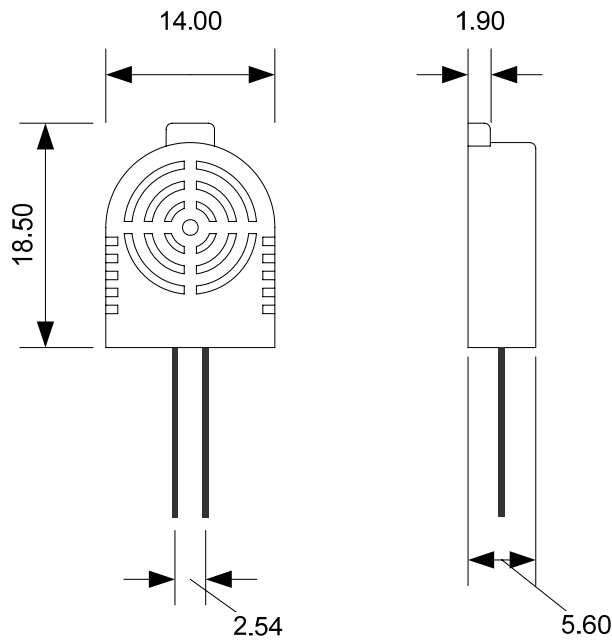

< SYH-2R C >

**Fig. 2.** Standard characteristics

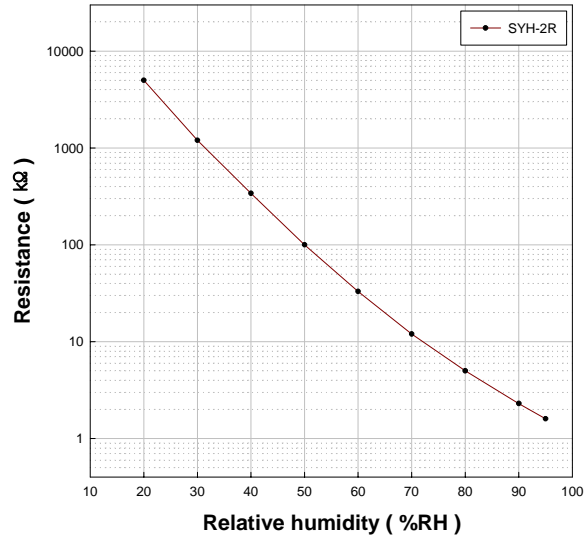

**Fig. 3.** Temperature characteristics

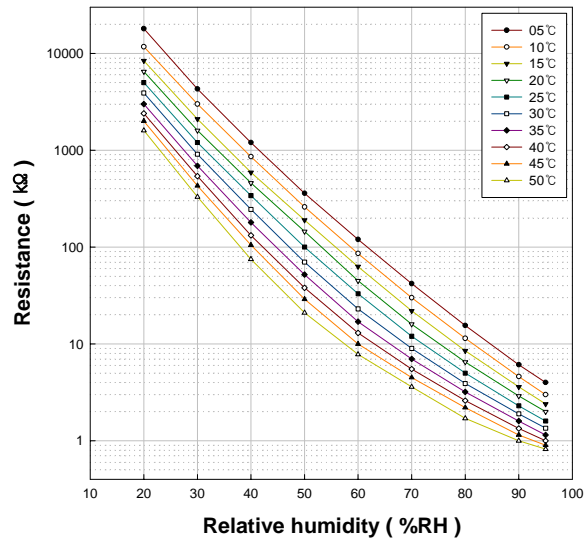

**Fig. 4.** Frequency characteristics

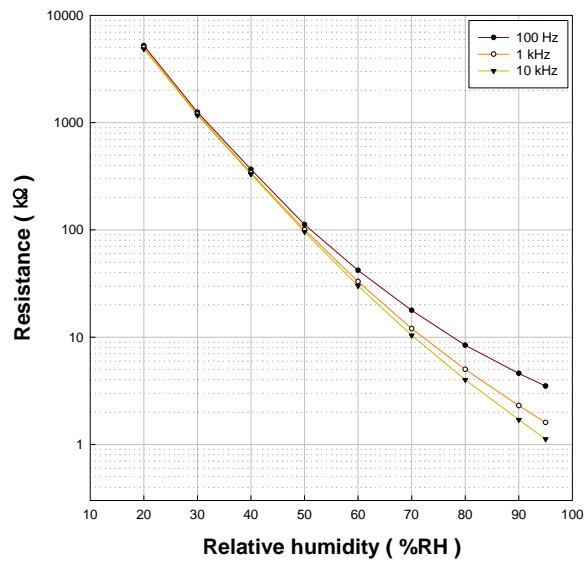
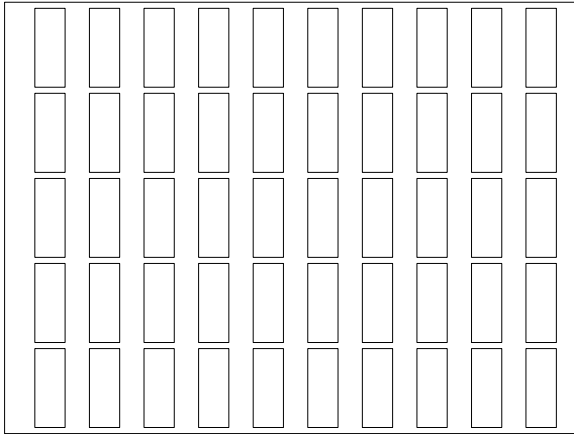



Fig. 5. Packaging

Tray: 50pcs / Tray (PET, 190×140×6 mm) for SYH-2RNC (without case) only



Vinyl Pouch: 100pcs / Pouch for SYH-2RC (with case)

Inlet Box: SYH-2RNC: 200×145×75 mm, 20 trays (1,000 pcs). Weight: 0.62Kg (approx)  
SYH-2RC: 280×280×55mm, 10 pouches (1,000 pcs). Weight: 1.2Kg (approx)

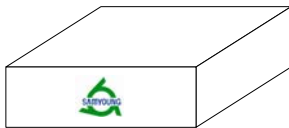

Outlet Box: (650×360×310 mm)

SYH-2RNC: 23 Inlet boxes (23K pcs). Weight 14.5Kg (approx)

SYH-2RC: 12 Inlet boxes (12K pcs). Weight 14.5Kg (approx)

