

CONTENT (MLCC)

E STANDARD NUMBER..... 3

STRUCTURE 4

ORDERING CODE 4

GENERAL PURPOSE 5

 CLASS I: TEMPERATURE COMPENSATING TYPE 6

 CLASS II: HIGH DIELECTRIC CONSTANT TYPE..... 12

X5R Series..... 12

X6S Series..... 17

X7R Series..... 18

Y5V Series..... 28

 TEST SPEC. 31

PACKAGE 35

OTHERS 39

E Standard Number

E3	1.0				2.2				4.7															
E6	1.0		1.5		2.2		3.3		4.7		6.8													
E12	1.0	1.2	1.5	1.8	2.2	2.7	3.3	3.9	4.7	5.6	6.8	8.2												
E24	1.0	1.1	1.2	1.3	1.5	1.6	1.8	2.0	2.2	2.4	2.7	3.0	3.3	3.6	3.9	4.3	4.7	5.1	5.6	6.2	6.8	7.5	8.2	9.1

MLCC

Structure

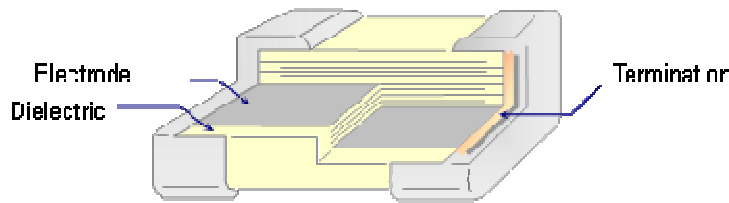

Ordering Code

C 1005 NP0 101 J G T S Δ

PRODUCT CODE

C = MLCC

SIZE in mm (EIA CODE, in inch)

0402(01005)	0603(0201)	1005 (0402)	1608 (0603)	2012 (0805)
3216 (1206)	3225(1210)	4520 (1808)	4532 (1812)	

T. C.

NP0: $0 \pm 30\text{ppm}/^\circ\text{C}$	-55°C to +125°C		
X7R: $\pm 15\%$	-55°C to +125°C	X6S: $\pm 22\%$	-55°C to +105°C
X5R: $\pm 15\%$	-55°C to +85°C	Y5V: $+22\%/-82\%$	-30°C to +85°C

CAPACITANCE CODE

Expressed in pico-farads and identified by a three-digit number.
 First two digits represent significant figures.
 Last digit specifies the number of zeros.
 (Use 9 for 1.0 through 9.9pF ; Use 8 for 0.20 through 0.99pF)

Examples:

Code	Cap (pF)
478	0.47
229	2.2
101	100
102	1000

TOLERANCE CODE

A: $\pm 0.05\text{pF}$	B: $\pm 0.1\text{pF}$	C: $\pm 0.25\text{pF}$	D: $\pm 0.5\text{pF}$	F: $\pm 1\%$	G: $\pm 2\%$
J: $\pm 5\%$	K: $\pm 10\%$	M: $\pm 20\%$	Z: $+80/-20\%$		

VOLTAGE CODE

B: 4V	C: 6.3V	D: 10V	E: 16V	F: 25V	N: 35V	G: 50V	H: 100V
J: 200V	K: 250V	L: 500V	M: 630V	P: 1KV	Q: 2KV	R: 3KV	S: 4KV

PACKAGING CODE

T: Paper tape reel Ø180mm (7")	P: Embossed tape reel Ø180mm (7")
N: Paper tape reel Ø250mm (10")	D: Embossed tape reel Ø250mm (10")
A: Paper tape reel Ø330mm (13")	E: Embossed tape reel Ø330mm (13")
W: Special Packing	

Application Code

S: Standard Q: High Q/Low ESR F: Microwave A: Automotive with AEC-Q200

Thickness Code

Code	Thick (mm)	Code	Thick(mm)	Code	Thick (mm)
(blank)	Standard Thick	M	0.70	H	1.50
Z	0.20	D	0.80	L	1.60
A	0.30	E	0.85	N	2.00
Q	0.45	I	0.95	P	2.50
B	0.50	F	1.15	R	3.20
C	0.60	G	1.25		

General Purpose

■ Standard External Dimensions

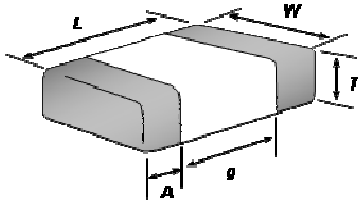

TYPE (EIA Size)	Dimension (mm)				
	L (Length)	W (Width)	T (Max.)	g (Min)	A (Min/Max)
C0603 (0201)	0.6 ± 0.03	0.30 ± 0.03	0.33	0.15	0.10 / 0.20
C1005 (0402)	1.0 ± 0.05	0.50 ± 0.05	0.55	0.30	0.15 / 0.35
C1608 (0603)	1.6 ± 0.10	0.80 ± 0.10	0.90	0.50	0.25 / 0.65
C2012 (0805)	2.0 ± 0.15	1.25 ± 0.15	1.45	0.70	0.25 / 0.75
C3216 (1206)	3.2 ± 0.15	1.60 ± 0.15	1.80	1.50	0.25 / 0.75
C3225 (1210)	3.2 ± 0.30	2.50 ± 0.20	2.70	1.50	0.25 / 0.75

For some special parts, please see the "Part Number & Characteristic" for detail specification.

■ Product Range

Class I: Temperature Compensating Type

TCC	Series	EIA	Capacitance Range (F)							
			0.1p	1p	10p	100p	1n	10n	100n	
NP0	C0603NP0_S	0201	0.2pF			100pF				
	C1005NP0_S	0402	0.2pF				1nF			
	C1608NP0_S	0603	0.3pF				3.3nF			
	C2012NP0_S	0805		1pF					10nF	
	C3216NP0_S	1206			10pF					39nF

Class II: High Dielectric Constant Type

TCC	Series	EIA	Capacitance Range (F)							
			100p	1n	10n	100n	1u	10u	100u	
X5R	C0603X5R	0201		2.2nF				2.2uF		
	C1005X5R	0402			15nF				10uF	
	C1608X5R	0603				100nF				47uF
	C2012X5R	0805					470nF			47uF
	C3216X5R	1206						2.2uF		100uF
	C3225X5R	1210						4.7uF		100uF
X6S	C0603X6S	0201				100nF	220nF			
	C1005X6S	0402					1uF	2.2uF		
	C1608X6S	0603							22uF	22uF
	C2012X6S	0805						10uF		47uF
	C3216X6S	1206							47uF	47uF
X7R	C0603X7R	0201	100pF			10nF				
	C1005X7R	0402	100pF					1uF		
	C1608X7R	0603	100pF					2.2uF		
	C2012X7R	0805		150pF						10uF
	C3216X7R	1206			1nF					22uF
	C3225X7R	1210						1uF		47uF
Y5V	C1005Y5V	0402			10nF			1uF		
	C1608Y5V	0603			10nF				4.7uF	
	C2012Y5V	0805				100nF				10uF
	C3216Y5V	1206						1uF		22uF
	C3225Y5V	1210							10uF	47uF

● **Class I: Temperature Compensating Type**

■ **Feature**

1. Ultra-stable
2. Tight tolerance available
3. Low ESR
4. Good frequency performance
5. No aging of capacitance
6. RoHS compliant

■ **Application**

1. LC and RC tuned circuit
2. Filtering
3. Timing

■ **Part Number & Characteristic**

● **C0603NP0_S Series (EIA0201)**

RV	DARFON P/N	Measuring Condition	Capacitance		Available Tolerance	Thick. (mm)	Tolerance(mm)		DF (max.)	Standard Packing
			Value	Unit			L/W	Thick.		
50V	C0603NP0208□GTS	1V, 1MHz	0.20	pF	±0.1pF,±0.05pF	0.30	±0.03	±0.03	0.25%	Paper,15Kpcs
	C0603NP0308□GTS	1V, 1MHz	0.30	pF	±0.1pF,±0.05pF	0.30	±0.03	±0.03	0.25%	
	C0603NP0408□GTS	1V, 1MHz	0.40	pF	±0.1pF,±0.05pF	0.30	±0.03	±0.03	0.25%	
	C0603NP0508□GTS	1V, 1MHz	0.50	pF	±0.25pF,±0.1pF,±0.05pF	0.30	±0.03	±0.03	0.24%	
	C0603NP0608□GTS	1V, 1MHz	0.60	pF	±0.1pF,±0.05pF	0.30	±0.03	±0.03	0.24%	
	C0603NP0708□GTS	1V, 1MHz	0.70	pF	±0.1pF,±0.05pF	0.30	±0.03	±0.03	0.24%	
	C0603NP0758□GTS	1V, 1MHz	0.75	pF	±0.1pF,±0.05pF	0.30	±0.03	±0.03	0.24%	
	C0603NP0808□GTS	1V, 1MHz	0.80	pF	±0.1pF,±0.05pF	0.30	±0.03	±0.03	0.24%	
	C0603NP0908□GTS	1V, 1MHz	0.90	pF	±0.1pF,±0.05pF	0.30	±0.03	±0.03	0.24%	
	C0603NP0109□GTS	1V, 1MHz	1.0	pF	±0.25pF,±0.1pF,±0.05pF	0.30	±0.03	±0.03	0.24%	
	C0603NP0119□GTS	1V, 1MHz	1.1	pF	±0.25pF,±0.1pF	0.30	±0.03	±0.03	0.24%	
	C0603NP0129□GTS	1V, 1MHz	1.2	pF	±0.25pF,±0.1pF	0.30	±0.03	±0.03	0.24%	
	C0603NP0159□GTS	1V, 1MHz	1.5	pF	±0.25pF,±0.1pF	0.30	±0.03	±0.03	0.23%	
	C0603NP0169□GTS	1V, 1MHz	1.6	pF	±0.25pF,±0.1pF	0.30	±0.03	±0.03	0.23%	
	C0603NP0189□GTS	1V, 1MHz	1.8	pF	±0.25pF,±0.1pF	0.30	±0.03	±0.03	0.23%	
	C0603NP0209□GTS	1V, 1MHz	2.0	pF	±0.25pF,±0.1pF	0.30	±0.03	±0.03	0.23%	
	C0603NP0229□GTS	1V, 1MHz	2.2	pF	±0.25pF,±0.1pF	0.30	±0.03	±0.03	0.23%	
	C0603NP0249□GTS	1V, 1MHz	2.4	pF	±0.25pF,±0.1pF	0.30	±0.03	±0.03	0.22%	
	C0603NP0279□GTS	1V, 1MHz	2.7	pF	±0.25pF,±0.1pF	0.30	±0.03	±0.03	0.22%	
	C0603NP0309□GTS	1V, 1MHz	3.0	pF	±0.25pF,±0.1pF	0.30	±0.03	±0.03	0.22%	
	C0603NP0339□GTS	1V, 1MHz	3.3	pF	±0.25pF,±0.1pF	0.30	±0.03	±0.03	0.21%	
	C0603NP0399□GTS	1V, 1MHz	3.9	pF	±0.25pF,±0.1pF	0.30	±0.03	±0.03	0.21%	
	C0603NP0409□GTS	1V, 1MHz	4.0	pF	±0.25pF,±0.1pF	0.30	±0.03	±0.03	0.21%	
	C0603NP0439□GTS	1V, 1MHz	4.3	pF	±0.25pF,±0.1pF	0.30	±0.03	±0.03	0.21%	
	C0603NP0479□GTS	1V, 1MHz	4.7	pF	±0.25pF,±0.1pF	0.30	±0.03	±0.03	0.20%	
	C0603NP0509□GTS	1V, 1MHz	5.0	pF	±0.25pF,±0.1pF	0.30	±0.03	±0.03	0.20%	
	C0603NP0519□GTS	1V, 1MHz	5.1	pF	±0.25pF,±0.1pF	0.30	±0.03	±0.03	0.20%	
	C0603NP0569□GTS	1V, 1MHz	5.6	pF	±0.5pF,±0.25pF,±0.1pF	0.30	±0.03	±0.03	0.20%	
	C0603NP0609□GTS	1V, 1MHz	6.0	pF	±0.5pF,±0.25pF,±0.1pF	0.30	±0.03	±0.03	0.19%	
	C0603NP0689□GTS	1V, 1MHz	6.8	pF	±0.5pF,±0.25pF,±0.1pF	0.30	±0.03	±0.03	0.19%	
	C0603NP0709□GTS	1V, 1MHz	7.0	pF	±0.5pF,±0.25pF,±0.1pF	0.30	±0.03	±0.03	0.19%	
	C0603NP0759□GTS	1V, 1MHz	7.5	pF	±0.5pF,±0.25pF,±0.1pF	0.30	±0.03	±0.03	0.18%	
	C0603NP0809□GTS	1V, 1MHz	8.0	pF	±0.5pF,±0.25pF,±0.1pF	0.30	±0.03	±0.03	0.18%	
	C0603NP0829□GTS	1V, 1MHz	8.2	pF	±0.5pF,±0.25pF,±0.1pF	0.30	±0.03	±0.03	0.18%	
	C0603NP0909□GTS	1V, 1MHz	9.0	pF	±0.5pF,±0.25pF,±0.1pF	0.30	±0.03	±0.03	0.17%	
	C0603NP0100□GTS	1V, 1MHz	10	pF	±5%,±2%,±1%	0.30	±0.03	±0.03	0.17%	
	C0603NP0120□GTS	1V, 1MHz	12	pF	±5%,±2%,±1%	0.30	±0.03	±0.03	0.16%	
	C0603NP0150□GTS	1V, 1MHz	15	pF	±5%,±2%,±1%	0.30	±0.03	±0.03	0.14%	
	C0603NP0180□GTS	1V, 1MHz	18	pF	±5%,±2%,±1%	0.30	±0.03	±0.03	0.13%	
	C0603NP0200□GTS	1V, 1MHz	20	pF	±5%	0.30	±0.03	±0.03	0.13%	
C0603NP0220□GTS	1V, 1MHz	22	pF	±5%,±2%,±1%	0.30	±0.03	±0.03	0.12%		
C0603NP0270□GTS	1V, 1MHz	27	pF	±5%,±2%,±1%	0.30	±0.03	±0.03	0.11%		
C0603NP0330□GTS	1V, 1MHz	33	pF	±5%,±2%,±1%	0.30	±0.03	±0.03	0.10%		
C0603NP0390□GTS	1V, 1MHz	39	pF	±5%,±2%,±1%	0.30	±0.03	±0.03	0.10%		
C0603NP0470□GTS	1V, 1MHz	47	pF	±5%,±2%,±1%	0.30	±0.03	±0.03	0.10%		
C0603NP0560□GTS	1V, 1MHz	56	pF	±5%,±2%,±1%	0.30	±0.03	±0.03	0.10%		
C0603NP0680□GTS	1V, 1MHz	68	pF	±5%,±2%,±1%	0.30	±0.03	±0.03	0.10%		
C0603NP0820□GTS	1V, 1MHz	82	pF	±5%,±2%,±1%	0.30	±0.03	±0.03	0.10%		
C0603NP0910□GTS	1V, 1MHz	91	pF	±5%	0.30	±0.03	±0.03	0.10%		
C0603NP0101□GTS	1V, 1MHz	100	pF	±5%,±2%,±1%	0.30	±0.03	±0.03	0.10%		

RV	DARFON P/N	Measuring Condition	Capacitance		Available Tolerance	Thick. (mm)	Tolerance(mm)		DF (max.)	Standard Packing	
			Value	Unit			L/W	Thick.			
25V	C0603NP0208	FTS	1V, 1MHz	0.20	pF	±0.1pF,±0.05pF	0.30	±0.03	±0.03	0.25%	Paper,15Kpcs
	C0603NP0308	FTS	1V, 1MHz	0.30	pF	±0.1pF,±0.05pF	0.30	±0.03	±0.03	0.25%	
	C0603NP0408	FTS	1V, 1MHz	0.40	pF	±0.1pF,±0.05pF	0.30	±0.03	±0.03	0.25%	
	C0603NP0508	FTS	1V, 1MHz	0.50	pF	±0.25pF,±0.1pF,±0.05pF	0.30	±0.03	±0.03	0.24%	
	C0603NP0608	FTS	1V, 1MHz	0.60	pF	±0.1pF,±0.05pF	0.30	±0.03	±0.03	0.24%	
	C0603NP0708	FTS	1V, 1MHz	0.70	pF	±0.1pF,±0.05pF	0.30	±0.03	±0.03	0.24%	
	C0603NP0758	FTS	1V, 1MHz	0.75	pF	±0.1pF,±0.05pF	0.30	±0.03	±0.03	0.24%	
	C0603NP0808	FTS	1V, 1MHz	0.80	pF	±0.1pF,±0.05pF	0.30	±0.03	±0.03	0.24%	
	C0603NP0908	FTS	1V, 1MHz	0.90	pF	±0.1pF,±0.05pF	0.30	±0.03	±0.03	0.24%	
	C0603NP0109	FTS	1V, 1MHz	1.0	pF	±0.25pF,±0.1pF,±0.05pF	0.30	±0.03	±0.03	0.24%	
	C0603NP0129	FTS	1V, 1MHz	1.2	pF	±0.25pF,±0.1pF	0.30	±0.03	±0.03	0.24%	
	C0603NP0159	FTS	1V, 1MHz	1.5	pF	±0.25pF,±0.1pF	0.30	±0.03	±0.03	0.23%	
	C0603NP0169	FTS	1V, 1MHz	1.6	pF	±0.25pF,±0.1pF	0.30	±0.03	±0.03	0.23%	
	C0603NP0189	FTS	1V, 1MHz	1.8	pF	±0.25pF,±0.1pF	0.30	±0.03	±0.03	0.23%	
	C0603NP0209	FTS	1V, 1MHz	2.0	pF	±0.25pF,±0.1pF	0.30	±0.03	±0.03	0.23%	
	C0603NP0229	FTS	1V, 1MHz	2.2	pF	±0.25pF,±0.1pF	0.30	±0.03	±0.03	0.23%	
	C0603NP0279	FTS	1V, 1MHz	2.7	pF	±0.25pF,±0.1pF	0.30	±0.03	±0.03	0.22%	
	C0603NP0309	FTS	1V, 1MHz	3.0	pF	±0.25pF,±0.1pF	0.30	±0.03	±0.03	0.22%	
	C0603NP0339	FTS	1V, 1MHz	3.3	pF	±0.25pF,±0.1pF	0.30	±0.03	±0.03	0.21%	
	C0603NP0399	FTS	1V, 1MHz	3.9	pF	±0.25pF,±0.1pF	0.30	±0.03	±0.03	0.21%	
	C0603NP0409	FTS	1V, 1MHz	4.0	pF	±0.25pF,±0.1pF	0.30	±0.03	±0.03	0.21%	
	C0603NP0439	FTS	1V, 1MHz	4.3	pF	±0.25pF,±0.1pF	0.30	±0.03	±0.03	0.21%	
	C0603NP0479	FTS	1V, 1MHz	4.7	pF	±0.25pF,±0.1pF	0.30	±0.03	±0.03	0.20%	
	C0603NP0509	FTS	1V, 1MHz	5.0	pF	±0.25pF,±0.1pF	0.30	±0.03	±0.03	0.20%	
	C0603NP0519	FTS	1V, 1MHz	5.1	pF	±0.25pF,±0.1pF	0.30	±0.03	±0.03	0.20%	
	C0603NP0569	FTS	1V, 1MHz	5.6	pF	±0.5pF,±0.25pF,±0.1pF	0.30	±0.03	±0.03	0.20%	
	C0603NP0609	FTS	1V, 1MHz	6.0	pF	±0.5pF,±0.25pF,±0.1pF	0.30	±0.03	±0.03	0.19%	
	C0603NP0689	FTS	1V, 1MHz	6.8	pF	±0.5pF,±0.25pF,±0.1pF	0.30	±0.03	±0.03	0.19%	
	C0603NP0709	FTS	1V, 1MHz	7.0	pF	±0.5pF,±0.25pF,±0.1pF	0.30	±0.03	±0.03	0.19%	
	C0603NP0759	FTS	1V, 1MHz	7.5	pF	±0.5pF,±0.25pF,±0.1pF	0.30	±0.03	±0.03	0.18%	
	C0603NP0809	FTS	1V, 1MHz	8.0	pF	±0.5pF,±0.25pF,±0.1pF	0.30	±0.03	±0.03	0.18%	
	C0603NP0829	FTS	1V, 1MHz	8.2	pF	±0.5pF,±0.25pF,±0.1pF	0.30	±0.03	±0.03	0.18%	
	C0603NP0909	FTS	1V, 1MHz	9.0	pF	±0.5pF,±0.25pF,±0.1pF	0.30	±0.03	±0.03	0.17%	
C0603NP0100	FTS	1V, 1MHz	10	pF	±5%,±2%,±1%	0.30	±0.03	±0.03	0.17%		
C0603NP0120	FTS	1V, 1MHz	12	pF	±5%,±2%,±1%	0.30	±0.03	±0.03	0.16%		
C0603NP0150	FTS	1V, 1MHz	15	pF	±5%,±2%,±1%	0.30	±0.03	±0.03	0.14%		
C0603NP0180	FTS	1V, 1MHz	18	pF	±5%,±2%,±1%	0.30	±0.03	±0.03	0.13%		
C0603NP0200	FTS	1V, 1MHz	20	pF	±5%	0.30	±0.03	±0.03	0.13%		
C0603NP0220	FTS	1V, 1MHz	22	pF	±5%,±2%,±1%	0.30	±0.03	±0.03	0.12%		
C0603NP0240	FTS	1V, 1MHz	24	pF	±5%,±2%,±1%	0.30	±0.03	±0.03	0.11%		
C0603NP0270	FTS	1V, 1MHz	27	pF	±5%,±2%,±1%	0.30	±0.03	±0.03	0.11%		
C0603NP0330	FTS	1V, 1MHz	33	pF	±5%,±2%,±1%	0.30	±0.03	±0.03	0.10%		
C0603NP0390	FTS	1V, 1MHz	39	pF	±5%,±2%,±1%	0.30	±0.03	±0.03	0.10%		
C0603NP0470	FTS	1V, 1MHz	47	pF	±5%,±2%,±1%	0.30	±0.03	±0.03	0.10%		
C0603NP0560	FTS	1V, 1MHz	56	pF	±5%,±2%,±1%	0.30	±0.03	±0.03	0.10%		
C0603NP0680	FTS	1V, 1MHz	68	pF	±5%,±2%,±1%	0.30	±0.03	±0.03	0.10%		
C0603NP0820	FTS	1V, 1MHz	82	pF	±5%,±2%,±1%	0.30	±0.03	±0.03	0.10%		
C0603NP0910	FTS	1V, 1MHz	91	pF	±5%	0.30	±0.03	±0.03	0.10%		
C0603NP0101	FTS	1V, 1MHz	100	pF	±5%,±2%,±1%	0.30	±0.03	±0.03	0.10%		
16V	C0603NP0279	ETS	1V, 1MHz	2.7	pF	±0.25pF,±0.1pF	0.30	±0.03	±0.03	0.22%	Paper,15Kpcs
	C0603NP0330	ETS	1V, 1MHz	33	pF	±5%	0.30	±0.03	±0.03	0.10%	

□ Tolerance Code: A=±0.05 pF, B=±0.1pF, C=±0.25pF ,D=±0.5pF, F=±1%, G=±2%, J=±5%; Special tolerance on the request.

● C1005NP0_S Series (EIA0402)

RV	DARFON P/N	Measuring Condition	Capacitance		Available Tolerance	Thick. (mm)	Tolerance(mm)		DF (max.)	Standard Packing
			Value	Unit			L/W	Thick.		
50V	C1005NP0208□GTS	1V, 1MHz	0.20	pF	±0.1pF	0.50	±0.05	±0.05	0.25%	Paper, 10Kpcs
	C1005NP0308□GTS	1V, 1MHz	0.30	pF	±0.1pF,±0.05pF	0.50	±0.05	±0.05	0.25%	
	C1005NP0408□GTS	1V, 1MHz	0.40	pF	±0.1pF,±0.05pF	0.50	±0.05	±0.05	0.25%	
	C1005NP0508□GTS	1V, 1MHz	0.50	pF	±0.25pF,±0.1pF,±0.05pF	0.50	±0.05	±0.05	0.24%	
	C1005NP0608□GTS	1V, 1MHz	0.60	pF	±0.1pF,±0.05pF	0.50	±0.05	±0.05	0.24%	
	C1005NP0708□GTS	1V, 1MHz	0.70	pF	±0.1pF,±0.05pF	0.50	±0.05	±0.05	0.24%	
	C1005NP0808□GTS	1V, 1MHz	0.80	pF	±0.1pF,±0.05pF	0.50	±0.05	±0.05	0.24%	
	C1005NP0908□GTS	1V, 1MHz	0.90	pF	±0.1pF,±0.05pF	0.50	±0.05	±0.05	0.24%	
	C1005NP0109□GTS	1V, 1MHz	1.0	pF	±0.25pF,±0.1pF	0.50	±0.05	±0.05	0.24%	
	C1005NP0129□GTS	1V, 1MHz	1.2	pF	±0.25pF,±0.1pF	0.50	±0.05	±0.05	0.24%	
	C1005NP0159□GTS	1V, 1MHz	1.5	pF	±0.25pF,±0.1pF	0.50	±0.05	±0.05	0.23%	
	C1005NP0189□GTS	1V, 1MHz	1.8	pF	±0.25pF,±0.1pF	0.50	±0.05	±0.05	0.23%	
	C1005NP0209□GTS	1V, 1MHz	2.0	pF	±0.25pF,±0.1pF	0.50	±0.05	±0.05	0.23%	
	C1005NP0229□GTS	1V, 1MHz	2.2	pF	±0.25pF,±0.1pF	0.50	±0.05	±0.05	0.23%	
	C1005NP0249□GTS	1V, 1MHz	2.4	pF	±0.25pF,±0.1pF	0.50	±0.05	±0.05	0.22%	
	C1005NP0279□GTS	1V, 1MHz	2.7	pF	±0.25pF,±0.1pF	0.50	±0.05	±0.05	0.22%	
	C1005NP0309□GTS	1V, 1MHz	3.0	pF	±0.25pF,±0.1pF	0.50	±0.05	±0.05	0.22%	
	C1005NP0339□GTS	1V, 1MHz	3.3	pF	±0.25pF,±0.1pF	0.50	±0.05	±0.05	0.21%	
	C1005NP0369□GTS	1V, 1MHz	3.6	pF	±0.25pF,±0.1pF	0.50	±0.05	±0.05	0.21%	
	C1005NP0399□GTS	1V, 1MHz	3.9	pF	±0.25pF,±0.1pF	0.50	±0.05	±0.05	0.21%	
	C1005NP0409□GTS	1V, 1MHz	4.0	pF	±0.25pF,±0.1pF	0.50	±0.05	±0.05	0.21%	
	C1005NP0439□GTS	1V, 1MHz	4.3	pF	±0.25pF,±0.1pF	0.50	±0.05	±0.05	0.21%	
	C1005NP0479□GTS	1V, 1MHz	4.7	pF	±0.25pF,±0.1pF	0.50	±0.05	±0.05	0.20%	
	C1005NP0509□GTS	1V, 1MHz	5.0	pF	±0.5pF,±0.25pF,±0.1pF	0.50	±0.05	±0.05	0.20%	
	C1005NP0519□GTS	1V, 1MHz	5.1	pF	±0.5pF,±0.25pF,±0.1pF	0.50	±0.05	±0.05	0.20%	
	C1005NP0569□GTS	1V, 1MHz	5.6	pF	±0.5pF,±0.25pF,±0.1pF	0.50	±0.05	±0.05	0.20%	
	C1005NP0609□GTS	1V, 1MHz	6.0	pF	±0.5pF,±0.25pF,±0.1pF	0.50	±0.05	±0.05	0.19%	
	C1005NP0629□GTS	1V, 1MHz	6.2	pF	±0.5pF,±0.25pF,±0.1pF	0.50	±0.05	±0.05	0.19%	
	C1005NP0689□GTS	1V, 1MHz	6.8	pF	±0.5pF,±0.25pF,±0.1pF	0.50	±0.05	±0.05	0.19%	
	C1005NP0709□GTS	1V, 1MHz	7.0	pF	±0.5pF,±0.25pF,±0.1pF	0.50	±0.05	±0.05	0.19%	
	C1005NP0759□GTS	1V, 1MHz	7.5	pF	±0.5pF,±0.25pF,±0.1pF	0.50	±0.05	±0.05	0.18%	
	C1005NP0809□GTS	1V, 1MHz	8.0	pF	±0.5pF,±0.25pF,±0.1pF	0.50	±0.05	±0.05	0.18%	
	C1005NP0829□GTS	1V, 1MHz	8.2	pF	±0.5pF,±0.25pF,±0.1pF	0.50	±0.05	±0.05	0.18%	
	C1005NP0909□GTS	1V, 1MHz	9.0	pF	±0.5pF,±0.25pF,±0.1pF	0.50	±0.05	±0.05	0.17%	
	C1005NP0919□GTS	1V, 1MHz	9.1	pF	±0.5pF,±0.25pF,±0.1pF	0.50	±0.05	±0.05	0.17%	
	C1005NP0100□GTS	1V, 1MHz	10	pF	±5%,±2%,±1%	0.50	±0.05	±0.05	0.17%	
	C1005NP0110□GTS	1V, 1MHz	11	pF	±5%,±2%,±1%	0.50	±0.05	±0.05	0.16%	
	C1005NP0120□GTS	1V, 1MHz	12	pF	±5%,±2%,±1%	0.50	±0.05	±0.05	0.16%	
	C1005NP0150□GTS	1V, 1MHz	15	pF	±5%,±2%,±1%	0.50	±0.05	±0.05	0.14%	
	C1005NP0160□GTS	1V, 1MHz	16	pF	±5%,±2%,±1%	0.50	±0.05	±0.05	0.14%	
	C1005NP0180□GTS	1V, 1MHz	18	pF	±5%,±2%,±1%	0.50	±0.05	±0.05	0.13%	
	C1005NP0200□GTS	1V, 1MHz	20	pF	±5%,±2%,±1%	0.50	±0.05	±0.05	0.13%	
C1005NP0220□GTS	1V, 1MHz	22	pF	±5%,±2%,±1%	0.50	±0.05	±0.05	0.12%		
C1005NP0240□GTS	1V, 1MHz	24	pF	±5%,±2%,±1%	0.50	±0.05	±0.05	0.11%		
C1005NP0270□GTS	1V, 1MHz	27	pF	±5%,±2%,±1%	0.50	±0.05	±0.05	0.11%		
C1005NP0300□GTS	1V, 1MHz	30	pF	±5%,±2%,±1%	0.50	±0.05	±0.05	0.10%		
C1005NP0330□GTS	1V, 1MHz	33	pF	±5%,±2%,±1%	0.50	±0.05	±0.05	0.10%		
C1005NP0360□GTS	1V, 1MHz	36	pF	±5%,±2%,±1%	0.50	±0.05	±0.05	0.10%		
C1005NP0390□GTS	1V, 1MHz	39	pF	±5%,±2%,±1%	0.50	±0.05	±0.05	0.10%		
C1005NP0430□GTS	1V, 1MHz	43	pF	±5%,±2%,±1%	0.50	±0.05	±0.05	0.10%		
C1005NP0470□GTS	1V, 1MHz	47	pF	±5%,±2%,±1%	0.50	±0.05	±0.05	0.10%		
C1005NP0510□GTS	1V, 1MHz	51	pF	±5%	0.50	±0.05	±0.05	0.10%		
C1005NP0560□GTS	1V, 1MHz	56	pF	±5%,±2%,±1%	0.50	±0.05	±0.05	0.10%		
C1005NP0620□GTS	1V, 1MHz	62	pF	±5%,±2%,±1%	0.50	±0.05	±0.05	0.10%		
C1005NP0680□GTS	1V, 1MHz	68	pF	±5%,±2%,±1%	0.50	±0.05	±0.05	0.10%		
C1005NP0750□GTS	1V, 1MHz	75	pF	±5%,±2%,±1%	0.50	±0.05	±0.05	0.10%		
C1005NP0820□GTS	1V, 1MHz	82	pF	±5%,±2%,±1%	0.50	±0.05	±0.05	0.10%		
C1005NP0910□GTS	1V, 1MHz	91	pF	±5%,±2%,±1%	0.50	±0.05	±0.05	0.10%		
C1005NP0101□GTS	1V, 1MHz	100	pF	±5%,±2%,±1%	0.50	±0.05	±0.05	0.10%		
C1005NP0121□GTS	1V, 1MHz	120	pF	5%	0.50	±0.05	±0.05	0.10%		
C1005NP0151□GTS	1V, 1MHz	150	pF	5%	0.50	±0.05	±0.05	0.10%		
C1005NP0181□GTS	1V, 1MHz	180	pF	5%	0.50	±0.05	±0.05	0.10%		
C1005NP0201□GTS	1V, 1MHz	200	pF	5%	0.50	±0.05	±0.05	0.10%		
C1005NP0221□GTS	1V, 1MHz	220	pF	5%	0.50	±0.05	±0.05	0.10%		

RV	DARFON P/N	Measuring Condition	Capacitance		Available Tolerance	Thick. (mm)	Tolerance(mm)		DF (max.)	Standard Packing
			Value	Unit			L/W	Thick.		
50V	C1005NP0271□GTS	1V, 1MHz	270	pF	5%	0.50	±0.05	±0.05	0.10%	Paper, 10Kpcs
	C1005NP0301□GTS	1V, 1MHz	300	pF	5%	0.50	±0.05	±0.05	0.10%	
	C1005NP0331□GTS	1V, 1MHz	330	pF	5%	0.50	±0.05	±0.05	0.10%	
	C1005NP0391□GTS	1V, 1MHz	390	pF	5%	0.50	±0.05	±0.05	0.10%	
	C1005NP0471□GTS	1V, 1MHz	470	pF	5%	0.50	±0.05	±0.05	0.10%	
	C1005NP0561□GTS	1V, 1MHz	560	pF	5%	0.50	±0.05	±0.05	0.10%	
	C1005NP0681□GTS	1V, 1MHz	680	pF	5%	0.50	±0.05	±0.05	0.10%	
	C1005NP0821□GTS	1V, 1MHz	820	pF	5%	0.50	±0.05	±0.05	0.10%	
C1005NP0102□GTS	1V, 1MHz	1.0	nF	5%	0.50	±0.05	±0.05	0.10%		

● C1608NP0_S Series (EIA0603)

RV	DARFON P/N	Measuring Condition	Capacitance		Available Tolerance	Thick. (mm)	Tolerance(mm)		DF (max.)	Standard Packing
			Value	Unit			L/W	Thick.		
50V	C1608NP0308□GTS	1V, 1MHz	0.30	pF	±0.25pF,±0.1pF,±0.05pF	0.80	±0.10	±0.10	0.25%	Paper, 4Kpcs
	C1608NP0508□GTS	1V, 1MHz	0.50	pF	±0.25pF,±0.1pF,±0.05pF	0.80	±0.10	±0.10	0.24%	
	C1608NP0758□GTS	1V, 1MHz	0.75	pF	±0.25pF,±0.1pF,±0.05pF	0.80	±0.10	±0.10	0.24%	
	C1608NP0109□GTS	1V, 1MHz	1.0	pF	±0.25pF,±0.1pF	0.80	±0.10	±0.10	0.24%	
	C1608NP0129□GTS	1V, 1MHz	1.2	pF	±0.25pF,±0.1pF	0.80	±0.10	±0.10	0.24%	
	C1608NP0159□GTS	1V, 1MHz	1.5	pF	±0.25pF,±0.1pF	0.80	±0.10	±0.10	0.23%	
	C1608NP0189□GTS	1V, 1MHz	1.8	pF	±0.25pF,±0.1pF	0.80	±0.10	±0.10	0.23%	
	C1608NP0209□GTS	1V, 1MHz	2.0	pF	±0.25pF,±0.1pF	0.80	±0.10	±0.10	0.23%	
	C1608NP0229□GTS	1V, 1MHz	2.2	pF	±0.25pF,±0.1pF	0.80	±0.10	±0.10	0.23%	
	C1608NP0249□GTS	1V, 1MHz	2.4	pF	±0.25pF,±0.1pF	0.80	±0.10	±0.10	0.22%	
	C1608NP0279□GTS	1V, 1MHz	2.7	pF	±0.25pF,±0.1pF	0.80	±0.10	±0.10	0.22%	
	C1608NP0309□GTS	1V, 1MHz	3.0	pF	±0.25pF,±0.1pF	0.80	±0.10	±0.10	0.22%	
	C1608NP0339□GTS	1V, 1MHz	3.3	pF	±0.25pF,±0.1pF	0.80	±0.10	±0.10	0.21%	
	C1608NP0399□GTS	1V, 1MHz	3.9	pF	±0.25pF,±0.1pF	0.80	±0.10	±0.10	0.21%	
	C1608NP0409□GTS	1V, 1MHz	4.0	pF	±0.25pF,±0.1pF	0.80	±0.10	±0.10	0.21%	
	C1608NP0479□GTS	1V, 1MHz	4.7	pF	±0.25pF,±0.1pF	0.80	±0.10	±0.10	0.20%	
	C1608NP0509□GTS	1V, 1MHz	5.0	pF	±0.5pF,±0.25pF,±0.1pF	0.80	±0.10	±0.10	0.20%	
	C1608NP0569□GTS	1V, 1MHz	5.6	pF	±0.5pF,±0.25pF,±0.1pF	0.80	±0.10	±0.10	0.20%	
	C1608NP0609□GTS	1V, 1MHz	6.0	pF	±0.5pF,±0.25pF,±0.1pF	0.80	±0.10	±0.10	0.19%	
	C1608NP0689□GTS	1V, 1MHz	6.8	pF	±0.5pF,±0.25pF,±0.1pF	0.80	±0.10	±0.10	0.19%	
	C1608NP0709□GTS	1V, 1MHz	7.0	pF	±0.5pF,±0.25pF,±0.1pF	0.80	±0.10	±0.10	0.19%	
	C1608NP0829□GTS	1V, 1MHz	8.2	pF	±0.5pF,±0.25pF,±0.1pF	0.80	±0.10	±0.10	0.18%	
	C1608NP0909□GTS	1V, 1MHz	9.0	pF	±0.5pF,±0.25pF,±0.1pF	0.80	±0.10	±0.10	0.17%	
	C1608NP0100□GTS	1V, 1MHz	10	pF	±5%,±2%,±1%	0.80	±0.10	±0.10	0.17%	
	C1608NP0110□GTS	1V, 1MHz	11	pF	±5%,±2%,±1%	0.80	±0.10	±0.10	0.16%	
	C1608NP0120□GTS	1V, 1MHz	12	pF	±5%,±2%,±1%	0.80	±0.10	±0.10	0.16%	
	C1608NP0150□GTS	1V, 1MHz	15	pF	±5%,±2%,±1%	0.80	±0.10	±0.10	0.14%	
	C1608NP0180□GTS	1V, 1MHz	18	pF	±5%,±2%,±1%	0.80	±0.10	±0.10	0.13%	
	C1608NP0200□GTS	1V, 1MHz	20	pF	±5%,±2%,±1%	0.80	±0.10	±0.10	0.13%	
	C1608NP0220□GTS	1V, 1MHz	22	pF	±5%,±2%,±1%	0.80	±0.10	±0.10	0.12%	
	C1608NP0240□GTS	1V, 1MHz	24	pF	±5%,±2%,±1%	0.80	±0.10	±0.10	0.11%	
	C1608NP0270□GTS	1V, 1MHz	27	pF	±5%,±2%,±1%	0.80	±0.10	±0.10	0.11%	
	C1608NP0300□GTS	1V, 1MHz	30	pF	±5%,±2%,±1%	0.80	±0.10	±0.10	0.10%	
	C1608NP0330□GTS	1V, 1MHz	33	pF	±5%,±2%,±1%	0.80	±0.10	±0.10	0.10%	
	C1608NP0360□GTS	1V, 1MHz	36	pF	±5%,±2%,±1%	0.80	±0.10	±0.10	0.10%	
	C1608NP0390□GTS	1V, 1MHz	39	pF	±5%,±2%,±1%	0.80	±0.10	±0.10	0.10%	
	C1608NP0430□GTS	1V, 1MHz	43	pF	±5%,±2%,±1%	0.80	±0.10	±0.10	0.10%	
	C1608NP0470□GTS	1V, 1MHz	47	pF	±5%,±2%,±1%	0.80	±0.10	±0.10	0.10%	
	C1608NP0560□GTS	1V, 1MHz	56	pF	±5%,±2%,±1%	0.80	±0.10	±0.10	0.10%	
	C1608NP0620□GTS	1V, 1MHz	62	pF	±5%,±2%,±1%	0.80	±0.10	±0.10	0.10%	
	C1608NP0680□GTS	1V, 1MHz	68	pF	±5%,±2%,±1%	0.80	±0.10	±0.10	0.10%	
	C1608NP0750□GTS	1V, 1MHz	75	pF	±5%,±2%,±1%	0.80	±0.10	±0.10	0.10%	
C1608NP0820□GTS	1V, 1MHz	82	pF	±5%,±2%,±1%	0.80	±0.10	±0.10	0.10%		
C1608NP0910□GTS	1V, 1MHz	91	pF	±5%,±2%,±1%	0.80	±0.10	±0.10	0.10%		
C1608NP0101□GTS	1V, 1MHz	100	pF	±5%,±2%,±1%	0.80	±0.10	±0.10	0.10%		
C1608NP0121□GTS	1V, 1MHz	120	pF	5%	0.80	±0.10	±0.10	0.10%		
C1608NP0151□GTS	1V, 1MHz	150	pF	5%	0.80	±0.10	±0.10	0.10%		
C1608NP0181□GTS	1V, 1MHz	180	pF	5%	0.80	±0.10	±0.10	0.10%		
C1608NP0201□GTS	1V, 1MHz	200	pF	5%	0.80	±0.10	±0.10	0.10%		
C1608NP0221□GTS	1V, 1MHz	220	pF	5%	0.80	±0.10	±0.10	0.10%		

□ Tolerance Code: A=±0.05 pF, B=±0.1pF, C=±0.25pF ,D=±0.5pF, F=±1%, G=±2%, J=±5%; Special tolerance on the request.

RV	DARFON P/N	Measuring Condition	Capacitance		Available Tolerance	Thick. (mm)	Tolerance(mm)		DF (max.)	Standard Packing
			Value	Unit			L/W	Thick.		
50V	C1608NP0271□GTS	1V, 1MHz	270	pF	5%	0.80	±0.10	±0.10	0.10%	Paper, 4kpcs
	C1608NP0331□GTS	1V, 1MHz	330	pF	±5%,±2%	0.80	±0.10	±0.10	0.10%	
	C1608NP0391□GTS	1V, 1MHz	390	pF	5%	0.80	±0.10	±0.10	0.10%	
	C1608NP0471□GTS	1V, 1MHz	470	pF	5%	0.80	±0.10	±0.10	0.10%	
	C1608NP0561□GTS	1V, 1MHz	560	pF	5%	0.80	±0.10	±0.10	0.10%	
	C1608NP0681□GTS	1V, 1MHz	680	pF	5%	0.80	±0.10	±0.10	0.10%	
	C1608NP0821□GTS	1V, 1MHz	820	pF	5%	0.80	±0.10	±0.10	0.10%	
	C1608NP0102□GTS	1V, 1MHz	1.0	nF	5%	0.80	±0.10	±0.10	0.10%	
	C1608NP0122□GTS	1V, 1kHz	1.2	nF	5%	0.80	±0.10	±0.15	0.10%	
	C1608NP0152□GTS	1V, 1kHz	1.5	nF	5%	0.80	±0.10	±0.15	0.10%	
	C1608NP0182□GTS	1V, 1kHz	1.8	nF	5%	0.80	±0.10	±0.15	0.10%	
	C1608NP0222□GTS	1V, 1kHz	2.2	nF	5%	0.80	±0.10	±0.15	0.10%	
	C1608NP0332□GTS	1V, 1kHz	3.3	nF	5%	0.80	±0.15	±0.15	0.10%	
25V	C1608NP0103□GTS	1V, 1kHz	10.0	nF	5%	0.80	±0.15	±0.15	0.10%	
16V	C1608NP0272□ETS	1V, 1kHz	2.7	nF	5%	0.80	±0.10	±0.15	0.10%	
	C1608NP0332□ETS	1V, 1kHz	3.3	nF	5%	0.80	±0.10	±0.15	0.10%	

● C2012NP0_S Series (EIA0805)

RV	DARFON P/N	Measuring Condition	Capacitance		Available Tolerance	Thick. (mm)	Tolerance(mm)		DF (max.)	Standard Packing
			Value	Unit			L/W	Thick.		
50V	C2012NP0100□GTS	1V, 1MHz	10	pF	±5%,±2%	0.60	±0.15	±0.15	0.17%	Paper, 4kpcs
	C2012NP0120□GTS	1V, 1MHz	12	pF	±5%,±2%	0.60	±0.15	±0.15	0.16%	
	C2012NP0150□GTS	1V, 1MHz	15	pF	±5%,±2%	0.60	±0.15	±0.15	0.14%	
	C2012NP0180□GTS	1V, 1MHz	18	pF	±5%,±2%	0.60	±0.15	±0.15	0.13%	
	C2012NP0200□GTS	1V, 1MHz	20	pF	±5%,±2%	0.60	±0.15	±0.15	0.13%	
	C2012NP0220□GTS	1V, 1MHz	22	pF	±5%,±2%	0.60	±0.15	±0.15	0.12%	
	C2012NP0270□GTS	1V, 1MHz	27	pF	±5%,±2%	0.60	±0.15	±0.15	0.11%	
	C2012NP0300□GTS	1V, 1MHz	30	pF	±5%,±2%	0.60	±0.15	±0.15	0.10%	
	C2012NP0330□GTS	1V, 1MHz	33	pF	±5%,±2%	0.60	±0.15	±0.15	0.10%	
	C2012NP0360□GTS	1V, 1MHz	36	pF	±5%,±2%	0.60	±0.15	±0.15	0.10%	
	C2012NP0470□GTS	1V, 1MHz	47	pF	±5%,±2%	0.60	±0.15	±0.15	0.10%	
	C2012NP0680□GTS	1V, 1MHz	68	pF	±5%,±2%	0.60	±0.15	±0.15	0.10%	
	C2012NP0820□GTS	1V, 1MHz	82	pF	±5%,±2%	0.60	±0.15	±0.15	0.10%	
	C2012NP0101□GTS	1V, 1MHz	100	pF	±5%,±2%	0.60	±0.15	±0.15	0.10%	
	C2012NP0121□GTS	1V, 1MHz	120	pF	5%	0.60	±0.15	±0.15	0.10%	
	C2012NP0151□GTS	1V, 1MHz	150	pF	5%	0.60	±0.15	±0.15	0.10%	
	C2012NP0201□GTS	1V, 1MHz	200	pF	5%	0.60	±0.15	±0.15	0.10%	
	C2012NP0221□GTS	1V, 1MHz	220	pF	5%	0.60	±0.15	±0.15	0.10%	
	C2012NP0271□GTS	1V, 1MHz	270	pF	5%	0.60	±0.15	±0.15	0.10%	
	C2012NP0331□GTS	1V, 1MHz	330	pF	5%	0.60	±0.15	±0.15	0.10%	
	C2012NP0391□GTS	1V, 1MHz	390	pF	5%	0.60	±0.15	±0.15	0.10%	
	C2012NP0471□GTS	1V, 1MHz	470	pF	5%	0.60	±0.15	±0.15	0.10%	
	C2012NP0561□GTS	1V, 1MHz	560	pF	5%	0.60	±0.15	±0.15	0.10%	
	C2012NP0681□GTS	1V, 1MHz	680	pF	5%	0.60	±0.15	±0.15	0.10%	
	C2012NP0821□GTS	1V, 1MHz	820	pF	5%	0.60	±0.15	±0.15	0.10%	
	C2012NP0102□GTS	1V, 1MHz	1.0	nF	5%	0.60	±0.15	±0.15	0.10%	
	C2012NP0122□GTS	1V, 1kHz	1.2	nF	5%	0.85	±0.15	±0.15	0.10%	
	C2012NP0152□GTS	1V, 1kHz	1.5	nF	5%	0.85	±0.15	±0.15	0.10%	
	C2012NP0182□GTS	1V, 1kHz	1.8	nF	5%	0.85	±0.15	±0.15	0.10%	
	C2012NP0222□GTS	1V, 1kHz	2.2	nF	5%	0.85	±0.15	±0.15	0.10%	
	C2012NP0272□GTS	1V, 1kHz	2.7	nF	5%	0.85	±0.15	±0.15	0.10%	
	C2012NP0332□GTS	1V, 1kHz	3.3	nF	5%	0.85	±0.15	±0.15	0.10%	
	C2012NP0392□GTS	1V, 1kHz	3.9	nF	5%	0.85	±0.15	±0.15	0.10%	
	C2012NP0472□GTS	1V, 1kHz	4.7	nF	5%	0.85	±0.15	±0.15	0.10%	
	C2012NP0272□GPS	1V, 1kHz	2.7	nF	5%	1.25	±0.15	±0.20	0.10%	
	C2012NP0332□GPS	1V, 1kHz	3.3	nF	5%	1.25	±0.15	±0.20	0.10%	
C2012NP0392□GPS	1V, 1kHz	3.9	nF	5%	1.25	±0.15	±0.20	0.10%		
C2012NP0472□GPS	1V, 1kHz	4.7	nF	5%	1.25	±0.15	±0.20	0.10%		
C2012NP0562□GPS	1V, 1kHz	5.6	nF	5%	1.25	±0.15	±0.20	0.10%		
C2012NP0682□GPS	1V, 1kHz	6.8	nF	5%	1.25	±0.15	±0.20	0.10%		
C2012NP0822□GPS	1V, 1kHz	8.2	nF	5%	1.25	±0.15	±0.20	0.10%		
C2012NP0103□GTS	1V, 1kHz	10	nF	5%	0.85	±0.15	±0.10	0.10%	Paper, 4kpcs	
C2012NP0103□GPS	1V, 1kHz	10	nF	5%	1.25	±0.15	±0.20	0.10%	Embossed, 3kpcs	

● C3216NP0_S Series (EIA1206)

RV	DARFON P/N	Measuring Condition	Capacitance		Available Tolerance	Thick. (mm)	Tolerance(mm)		DF (max.)	Standard Packing
			Value	Unit			L/W	Thick.		
50V	C3216NP0100□GTS	1V, 1MHz	10	pF	±5%	0.85	±0.15	±0.15	0.17%	Paper, 4kpcs
	C3216NP0120□GTS	1V, 1MHz	12	pF	±5%	0.85	±0.15	±0.15	0.16%	
	C3216NP0150□GTS	1V, 1MHz	15	pF	±5%	0.85	±0.15	±0.15	0.14%	
	C3216NP0180□GTS	1V, 1MHz	18	pF	±5%	0.85	±0.15	±0.15	0.13%	
	C3216NP0220□GTS	1V, 1MHz	22	pF	±5%	0.85	±0.15	±0.15	0.12%	
	C3216NP0270□GTS	1V, 1MHz	27	pF	±5%	0.85	±0.15	±0.15	0.11%	
	C3216NP0330□GTS	1V, 1MHz	33	pF	±5%	0.85	±0.15	±0.15	0.10%	
	C3216NP0390□GTS	1V, 1MHz	39	pF	±5%	0.85	±0.15	±0.15	0.10%	
	C3216NP0470□GTS	1V, 1MHz	47	pF	±5%	0.85	±0.15	±0.15	0.10%	
	C3216NP0560□GTS	1V, 1MHz	56	pF	±5%	0.85	±0.15	±0.15	0.10%	
	C3216NP0680□GTS	1V, 1MHz	68	pF	±5%	0.85	±0.15	±0.15	0.10%	
	C3216NP0820□GTS	1V, 1MHz	82	pF	±5%	0.85	±0.15	±0.15	0.10%	
	C3216NP0101□GTS	1V, 1MHz	100	pF	±5%	0.85	±0.15	±0.15	0.10%	
	C3216NP0121□GTS	1V, 1MHz	120	pF	±5%	0.85	±0.15	±0.15	0.10%	
	C3216NP0151□GTS	1V, 1MHz	150	pF	±5%	0.85	±0.15	±0.15	0.10%	
	C3216NP0181□GTS	1V, 1MHz	180	pF	±5%	0.85	±0.15	±0.15	0.10%	
	C3216NP0221□GTS	1V, 1MHz	220	pF	±5%	0.85	±0.15	±0.15	0.10%	
	C3216NP0271□GTS	1V, 1MHz	270	pF	±5%	0.85	±0.15	±0.15	0.10%	
	C3216NP0331□GTS	1V, 1MHz	330	pF	±5%	0.85	±0.15	±0.15	0.10%	
	C3216NP0391□GTS	1V, 1MHz	390	pF	±5%	0.85	±0.15	±0.15	0.10%	
	C3216NP0471□GTS	1V, 1MHz	470	pF	±5%	0.85	±0.15	±0.15	0.10%	
	C3216NP0561□GTS	1V, 1MHz	560	pF	±5%	0.85	±0.15	±0.15	0.10%	
	C3216NP0681□GTS	1V, 1MHz	680	pF	±5%	0.85	±0.15	±0.15	0.10%	
	C3216NP0821□GTS	1V, 1MHz	820	pF	±5%	0.85	±0.15	±0.15	0.10%	
	C3216NP0102□GTS	1V, 1MHz	1.0	nF	±5%	0.85	±0.15	±0.15	0.10%	
	C3216NP0122□GTS	1V, 1kHz	1.2	nF	±5%	0.85	±0.15	±0.15	0.10%	
	C3216NP0152□GTS	1V, 1kHz	1.5	nF	±5%	0.85	±0.15	±0.15	0.10%	
	C3216NP0182□GTS	1V, 1kHz	1.8	nF	±5%	0.85	±0.15	±0.15	0.10%	
	C3216NP0222□GTS	1V, 1kHz	2.2	nF	±5%	0.85	±0.15	±0.15	0.10%	
	C3216NP0272□GTS	1V, 1kHz	2.7	nF	±5%	0.85	±0.15	±0.15	0.10%	
	C3216NP0332□GTS	1V, 1kHz	3.3	nF	±5%	0.85	±0.15	±0.15	0.10%	
	C3216NP0392□GTS	1V, 1kHz	3.9	nF	±5%	0.85	±0.15	±0.15	0.10%	
C3216NP0472□GTS	1V, 1kHz	4.7	nF	±5%	0.85	±0.15	±0.15	0.10%		
C3216NP0562□GTS	1V, 1kHz	5.6	nF	±5%	0.85	±0.15	±0.15	0.10%		
C3216NP0682□GPS	1V, 1kHz	6.8	nF	±5%	1.15	±0.15	±0.20	0.10%		
C3216NP0822□GPS	1V, 1kHz	8.2	nF	±5%	1.15	±0.15	±0.20	0.10%		
C3216NP0103□GPS	1V, 1kHz	10	nF	±5%	1.25	±0.15	±0.20	0.10%		
C3216NP0183□GTS	1V, 1kHz	18	nF	±5%	0.85	±0.20	±0.10	0.10%		
16V	C3216NP0123□EPS	1V, 1kHz	12	nF	±5%	1.25	±0.15	±0.20	0.10%	Embossed, 3kpcs
	C3216NP0153□EPS	1V, 1kHz	15	nF	±5%	1.25	±0.15	±0.20	0.10%	
	C3216NP0183□EPS	1V, 1kHz	18	nF	±5%	1.25	±0.15	±0.20	0.10%	
	C3216NP0223□EPS	1V, 1kHz	22	nF	±5%	1.25	±0.15	±0.20	0.10%	
	C3216NP0273□EPS	1V, 1kHz	27	nF	±5%	1.25	±0.15	±0.20	0.10%	
	C3216NP0333□EPS	1V, 1kHz	33	nF	±5%	1.25	±0.15	±0.20	0.10%	
C3216NP0393□EPS	1V, 1kHz	39	nF	±5%	1.60	±0.15	±0.20	0.10%	Embossed, 2kpcs	

□ Tolerance Code: A=±0.05 pF, B=±0.1pF, C=±0.25pF, D=±0.5pF, F=±1%, G=±2%, J=±5%; Special tolerance on the request.

● Class II: High Dielectric Constant Type

■ Feature

1. High volumetric efficiency
2. High insulation resistance
3. RoHS compliant

■ Application

1. Blocking
2. Coupling
3. Timing
4. Bypassing
5. Frequency discriminating
6. Flittering

■ Part Number & Characteristic

■ X5R Series

● C0603X5R Series(EIA0201)

RV	DARFON P/N	Measuring Condition	Capacitance		Available Tolerance	Thick. (mm)	Tolerance(mm)		DF (max.)	Standard Packing	Test Spec.
			Value	Unit			L/W	Thick.			
25V	C0603X5R103□ FTS	1V, 1kHz	100	nF	±10%, ±20%	0.30	± 0.03	± 0.03	5.0%	Paper, 15Kpccs	(II)*
	C0603X5R104□ FTS	1V, 1kHz	100	nF	±10%, ±20%	0.30	± 0.03	± 0.03	10.0%		(II)
16V	C0603X5R103□ ETS	1V, 1kHz	10	nF	±10%, ±20%	0.30	± 0.03	± 0.03	5.0%		(II)
	C0603X5R104□ ETS	1V, 1kHz	100	nF	±10%, ±20%	0.30	± 0.03	± 0.03	10.0%		(II)
10V	C0603X5R222□ DTS	1V, 1kHz	2.2	nF	±10%, ±20%	0.30	± 0.03	± 0.03	7.5%		(I)
	C0603X5R332□ DTS	1V, 1kHz	3.3	nF	±10%, ±20%	0.30	± 0.03	± 0.03	7.5%		(I)
	C0603X5R472□ DTS	1V, 1kHz	4.7	nF	±10%, ±20%	0.30	± 0.03	± 0.03	7.5%		(I)
	C0603X5R562□ DTS	1V, 1kHz	5.6	nF	±10%, ±20%	0.30	± 0.03	± 0.03	7.5%		(I)
	C0603X5R682□ DTS	1V, 1kHz	6.8	nF	±10%, ±20%	0.30	± 0.03	± 0.03	7.5%		(I)
	C0603X5R822□ DTS	1V, 1kHz	8.2	nF	±10%, ±20%	0.30	± 0.03	± 0.03	7.5%		(I)
	C0603X5R103□ DTS	1V, 1kHz	10	nF	±10%, ±20%	0.30	± 0.03	± 0.03	7.5%		(I)
	C0603X5R223□ DTS	1V, 1kHz	22	nF	±10%, ±20%	0.30	± 0.03	± 0.03	7.5%		(II)
	C0603X5R333□ DTS	1V, 1kHz	33	nF	±10%, ±20%	0.30	± 0.03	± 0.03	7.5%		(II)
	C0603X5R473□ DTS	1V, 1kHz	47	nF	±10%, ±20%	0.30	± 0.03	± 0.03	7.5%		(II)
	C0603X5R563□ DTS	1V, 1kHz	56	nF	±10%, ±20%	0.30	± 0.03	± 0.03	7.5%		(II)
	C0603X5R683□ DTS	1V, 1kHz	68	nF	±10%, ±20%	0.30	± 0.03	± 0.03	7.5%		(II)
	C0603X5R823□ DTS	1V, 1kHz	82	nF	±10%, ±20%	0.30	± 0.03	± 0.03	7.5%		(II)
	C0603X5R104□ DTS	0.5V, 1kHz	100	nF	±10%, ±20%	0.30	± 0.03	± 0.03	10.0%		(II)
	C0603X5R224□ DTS	0.5V, 1kHz	220	nF	±10%, ±20%	0.30	± 0.03	± 0.03	10.0%		(II)*
	C0603X5R474□ DTS	0.5V, 1kHz	470	nF	±10%, ±20%	0.30	± 0.03	± 0.03	12.5%		(II)*
C0603X5R105□ DTS	1V, 1kHz	1.0	uF	±20%	0.30	±0.09	±0.09	12.5%	(II)*		
C0603X5R225□ DTS	1V, 1kHz	2.2	uF	±20%	0.30	±0.09	±0.09	12.5%	(II)*		
6.3V	C0603X5R222□ CTS	1V, 1kHz	2.2	nF	±10%, ±20%	0.30	± 0.03	± 0.03	10.0%	(I)	
	C0603X5R332□ CTS	1V, 1kHz	3.3	nF	±10%, ±20%	0.30	± 0.03	± 0.03	10.0%	(I)	
	C0603X5R472□ CTS	1V, 1kHz	4.7	nF	±10%, ±20%	0.30	± 0.03	± 0.03	10.0%	(I)	
	C0603X5R562□ CTS	1V, 1kHz	5.6	nF	±10%, ±20%	0.30	± 0.03	± 0.03	10.0%	(I)	
	C0603X5R682□ CTS	1V, 1kHz	6.8	nF	±10%, ±20%	0.30	± 0.03	± 0.03	10.0%	(I)	
	C0603X5R822□ CTS	1V, 1kHz	8.2	nF	±10%, ±20%	0.30	± 0.03	± 0.03	10.0%	(I)	
	C0603X5R103□ CTS	1V, 1kHz	10	nF	±10%, ±20%	0.30	± 0.03	± 0.03	10.0%	(I)	
	C0603X5R223□ CTS	1V, 1kHz	22	nF	±10%, ±20%	0.30	± 0.03	± 0.03	10.0%	(II)	
	C0603X5R333□ CTS	1V, 1kHz	33	nF	±10%, ±20%	0.30	± 0.03	± 0.03	10.0%	(II)	
	C0603X5R473□ CTS	1V, 1kHz	47	nF	±10%, ±20%	0.30	± 0.03	± 0.03	10.0%	(II)	
	C0603X5R563□ CTS	1V, 1kHz	56	nF	±10%, ±20%	0.30	± 0.03	± 0.03	10.0%	(II)	
	C0603X5R683□ CTS	1V, 1kHz	68	nF	±10%, ±20%	0.30	± 0.03	± 0.03	10.0%	(II)	
	C0603X5R823□ CTS	1V, 1kHz	82	nF	±10%, ±20%	0.30	± 0.03	± 0.03	10.0%	(II)	
	C0603X5R104□ CTS	0.5V, 1kHz	100	nF	±10%, ±20%	0.30	± 0.03	± 0.03	10.0%	(II)	
	C0603X5R224□ CTS	0.5V, 1kHz	220	nF	±10%, ±20%	0.30	± 0.03	± 0.03	10.0%	(II)*	
	C0603X5R474□ CTS	0.5V, 1kHz	470	nF	±10%, ±20%	0.30	± 0.03	± 0.03	12.5%	(II)*	
C0603X5R105□ CTS	0.5V, 1kHz	1.0	uF	±10%, ±20%	0.30	±0.05	±0.05	12.5%	(II)*		
C0603X5R225□ CTS	0.5V, 1kHz	2.2	uF	±20%	0.30	±0.09	±0.09	20.0%	(II)*		
4V	C0603X5R224□ BTS	0.5V, 1kHz	220	nF	±10%, ±20%	0.30	± 0.03	± 0.03	10.0%	(II)	
	C0603X5R474□ BTS	0.5V, 1kHz	470	nF	±10%, ±20%	0.30	± 0.03	± 0.03	12.5%	(II)*	
	C0603X5R105□ BTS	0.5V, 1kHz	1.0	uF	±10%, ±20%	0.30	±0.05	±0.05	10.0%	(II)*	

● C1005X5R Series (EIA0402)

RV	DARFON P/N	Measuring Condition	Capacitance		Available Tolerance	Thick. (mm)	Tolerance(mm)		DF (max.)	Standard Packing	Test Spec.
			Value	Unit			L/W	Thick.			
50V	C1005X5R104□ GTS	1V, 1kHz	100	nF	±10%, ±20%	0.50	±0.05	±0.05	10.0%	Paper, 10kpcs	(II)
35V	C1005X5R105□ NTS	1V, 1kHz	1.0	uF	±10%, ±20%	0.50	±0.10	±0.10	10.0%	Paper, 10kpcs	(II)*

□ Tolerance Code: J=±5%, K=±10%, M=±20% ;Special tolerance on the request.

(II)* High temperature load life test are applicable in rated voltage *100%

RV	DARFON P/N	Measuring Condition	Capacitance		Available Tolerance	Thick. (mm)	Tolerance(mm)		DF (max.)	Standard Packing	Test Spec.
			Value	Unit			L/W	Thick.			
25V	C1005X5R223□ FTS	1V, 1kHz	22	nF	±10%	0.50	±0.05	±0.05	3.0%	Paper, 10kpcs	(I)
	C1005X5R104□ FTS	1V, 1kHz	100	nF	±10%, ±20%	0.50	±0.05	±0.05	5.0%		(I)
	C1005X5R224□ FTS	1V, 1kHz	220	nF	±10%, ±20%	0.50	±0.05	±0.05	10.0%		(II)
	C1005X5R474□ FTS	1V, 1kHz	470	nF	±10%	0.50	±0.05	±0.05	12.5%		(II)
	C1005X5R105□ FTS	1V, 1kHz	1.0	uF	±10%, ±20%	0.50	±0.10	±0.10	12.5%		(II)*
C1005X5R225□ FTS	1V, 1kHz	2.2	uF	±10%, ±20%	0.50	±0.20	±0.20	10.0%	(II)		
16V	C1005X5R153□ ETS	1V, 1kHz	15	nF	±10%, ±20%	0.50	±0.05	±0.05	5.0%	Paper, 10kpcs	(I)
	C1005X5R223□ ETS	1V, 1kHz	22	nF	±10%, ±20%	0.50	±0.05	±0.05	5.0%		(I)
	C1005X5R333□ ETS	1V, 1kHz	33	nF	±10%, ±20%	0.50	±0.05	±0.05	5.0%		(I)
	C1005X5R473□ ETS	1V, 1kHz	47	nF	±10%, ±20%	0.50	±0.05	±0.05	5.0%		(I)
	C1005X5R563□ ETS	1V, 1kHz	56	nF	±10%, ±20%	0.50	±0.05	±0.05	5.0%		(I)
	C1005X5R683□ ETS	1V, 1kHz	68	nF	±10%, ±20%	0.50	±0.05	±0.05	5.0%		(I)
	C1005X5R823□ ETS	1V, 1kHz	82	nF	±10%, ±20%	0.50	±0.05	±0.05	5.0%		(I)
	C1005X5R104□ ETS	1V, 1kHz	100	nF	±10%, ±20%	0.50	±0.05	±0.05	5.0%		(I)
	C1005X5R124□ ETS	1V, 1kHz	120	nF	±10%, ±20%	0.50	±0.05	±0.05	7.5%		(II)
	C1005X5R154□ ETS	1V, 1kHz	150	nF	±10%, ±20%	0.50	±0.05	±0.05	7.5%		(II)
	C1005X5R184□ ETS	1V, 1kHz	180	nF	±10%, ±20%	0.50	±0.05	±0.05	7.5%		(II)
	C1005X5R224□ ETS	1V, 1kHz	220	nF	±10%, ±20%	0.50	±0.05	±0.05	10.0%		(II)
	C1005X5R334□ ETS	1V, 1kHz	330	nF	±10%, ±20%	0.50	±0.05	±0.05	12.5%		(II)
	C1005X5R474□ ETS	1V, 1kHz	470	nF	±10%, ±20%	0.50	±0.05	±0.05	12.5%		(II)
	C1005X5R684□ ETS	1V, 1kHz	680	nF	±10%, ±20%	0.50	±0.05	±0.05	12.5%		(II)
	C1005X5R105□ ETS	1V, 1kHz	1.0	uF	±10%, ±20%	0.50	±0.05	±0.05	12.5%		(II)
	C1005X5R225□ ETS	1V, 1kHz	2.2	uF	±10%, ±20%	0.50	±0.20	±0.20	12.5%		(II)*
C1005X5R475□ ETS	1V, 1kHz	4.7	uF	±20%	0.50	±0.20	±0.20	12.5%	(II)*		
10V	C1005X5R153□ DTS	1V, 1kHz	15	nF	±10%, ±20%	0.50	±0.05	±0.05	7.5%	Paper, 10kpcs	(I)
	C1005X5R223□ DTS	1V, 1kHz	22	nF	±10%, ±20%	0.50	±0.05	±0.05	7.5%		(I)
	C1005X5R333□ DTS	1V, 1kHz	33	nF	±10%, ±20%	0.50	±0.05	±0.05	7.5%		(I)
	C1005X5R473□ DTS	1V, 1kHz	47	nF	±10%, ±20%	0.50	±0.05	±0.05	7.5%		(I)
	C1005X5R223□ DTS	1V, 1kHz	22	nF	±10%, ±20%	0.50	±0.05	±0.05	7.5%		(I)
	C1005X5R333□ DTS	1V, 1kHz	33	nF	±10%, ±20%	0.50	±0.05	±0.05	7.5%		(I)
	C1005X5R473□ DTS	1V, 1kHz	47	nF	±10%, ±20%	0.50	±0.05	±0.05	7.5%		(I)
	C1005X5R563□ DTS	1V, 1kHz	56	nF	±10%, ±20%	0.50	±0.05	±0.05	7.5%		(I)
	C1005X5R683□ DTS	1V, 1kHz	68	nF	±10%, ±20%	0.50	±0.05	±0.05	7.5%		(I)
	C1005X5R823□ DTS	1V, 1kHz	82	nF	±10%, ±20%	0.50	±0.05	±0.05	7.5%		(I)
	C1005X5R104□ DTS	1V, 1kHz	100	nF	±10%, ±20%	0.50	±0.05	±0.05	7.5%		(I)
	C1005X5R124□ DTS	1V, 1kHz	120	nF	±10%, ±20%	0.50	±0.05	±0.05	7.5%		(II)
	C1005X5R154□ DTS	1V, 1kHz	150	nF	±10%, ±20%	0.50	±0.05	±0.05	7.5%		(II)
	C1005X5R184□ DTS	1V, 1kHz	180	nF	±10%, ±20%	0.50	±0.05	±0.05	7.5%		(II)
	C1005X5R224□ DTS	1V, 1kHz	220	nF	±10%, ±20%	0.50	±0.05	±0.05	7.5%		(II)
	C1005X5R334□ DTS	1V, 1kHz	330	nF	±10%, ±20%	0.50	±0.05	±0.05	10.0%		(II)
	C1005X5R394□ DTS	1V, 1kHz	390	nF	±10%, ±20%	0.50	±0.05	±0.05	10.0%		(II)
	C1005X5R474□ DTS	1V, 1kHz	470	nF	±10%, ±20%	0.50	±0.05	±0.05	10.0%		(II)
	C1005X5R684□ DTS	1V, 1kHz	680	nF	±10%, ±20%	0.50	±0.05	±0.05	10.0%		(II)
	C1005X5R105□ DTS	1V, 1kHz	1.0	uF	±10%, ±20%	0.50	±0.05	±0.05	10.0%		(II)
C1005X5R225□ DTS	0.5V, 1kHz	2.2	uF	±10%, ±20%	0.50	±0.05	±0.05	10.0%	(II)*		
C1005X5R475□ DTS	1V, 1kHz	4.7	uF	±10%, ±20%	0.50	±0.15	±0.15	12.5%	(II)*		
C1005X5R106□ DTS	0.5V, 1kHz	10	uF	±20%	0.50	±0.20	±0.20	12.5%	(II)*		
6.3V	C1005X5R224□ CTS	1V, 1kHz	220	nF	±10%, ±20%	0.50	±0.05	±0.05	10.0%	Paper, 10kpcs	(II)
	C1005X5R334□ CTS	1V, 1kHz	330	nF	±10%, ±20%	0.50	±0.05	±0.05	10.0%		(II)
	C1005X5R474□ CTS	1V, 1kHz	470	nF	±10%, ±20%	0.50	±0.05	±0.05	10.0%		(II)
	C1005X5R684□ CTS	1V, 1kHz	680	nF	±10%, ±20%	0.50	±0.05	±0.05	10.0%		(II)
	C1005X5R105□ MCTSA	1V, 1kHz	1.0	uF	±20%	0.30	±0.05	±0.03	12.5%		(II)*
	C1005X5R105□ CTS	0.5V, 1kHz	1.0	uF	±10%, ±20%	0.50	±0.05	±0.05	12.5%		(II)
	C1005X5R225□ MCTSA	0.5V, 1kHz	2.2	uF	±20%	0.30	±0.05	±0.03	10.0%		(II)*
	C1005X5R225□ CTS	0.5V, 1kHz	2.2	uF	±10%, ±20%	0.50	±0.05	±0.05	10.0%		(II)*
	C1005X5R475□ MCTSA	0.5V, 1kHz	4.7	uF	±20%	0.30	±0.20	±0.03	10.0%		(II)*
	C1005X5R475□ CTS	0.5V, 1kHz	4.7	uF	±10%, ±20%	0.50	±0.15	±0.15	10.0%		(II)*
C1005X5R106□ MCTS	0.5V, 1kHz	10	uF	±20%	0.50	±0.20	±0.20	15.0%	(II)*		
4V	C1005X5R105□ BTS	1V, 1kHz	1.0	uF	±10%, ±20%	0.50	±0.05	±0.05	15.0%	Paper, 10kpcs	(II)
	C1005X5R225□ BTS	0.5V, 1kHz	2.2	uF	±10%, ±20%	0.50	±0.05	±0.05	10.0%		(II)
	C1005X5R225□ MBTSA	0.5V, 1kHz	2.2	uF	±20%	0.30	±0.05	±0.03	10.0%		(II)
	C1005X5R475□ BTS	0.5V, 1kHz	4.7	uF	±10%, ±20%	0.50	±0.15	±0.15	10.0%		(II)
	C1005X5R106□ MBTSA	0.5V, 1kHz	10	uF	±20%	0.50	±0.20	±0.20	15.0%		(II)
C1005X5R226□ MBTSA	0.5V, 1kHz	22	uF	±20%	0.50	±0.40	±0.40	15.0%	Paper, 8kpcs	(II)*	

● C1608X5R Series (EIA0603)

RV	DARFON P/N	Measuring Condition	Capacitance		Available Tolerance	Thick. (mm)	Tolerance(mm)		DF (max.)	Standard Packing	Test Spec.	
			Value	Unit			L/W	Thick.				
50V	C1608X5R474□GTS	1V, 1kHz	470	nF	±10%, ±20%	0.80	±0.15	±0.15	10.0%	Paper, 4kpcs	(II)	
	C1608X5R105□GTS	1V, 1kHz	1.0	uF	±10%, ±20%	0.80	±0.10	±0.10	10.0%		(II)	
35V	C1608X5R105□NTS	1V, 1kHz	1.0	uF	±10%, ±20%	0.80	±0.10	±0.10	10.0%	Paper, 4kpcs	(II)	
	C1608X5R225□NTS	1V, 1kHz	2.2	uF	±10%, ±20%	0.80	±0.10	±0.10	10.0%		(II)*	
	C1608X5R475□NTS	1V, 1kHz	4.7	uF	±10%, ±20%	0.80	±0.20	±0.20	10.0%		(II)*	
25V	C1608X5R104□FTS	1V, 1kHz	100	nF	±10%, ±20%	0.80	±0.10	±0.10	5.0%	Paper, 4kpcs	(I)	
	C1608X5R224□FTS	1V, 1kHz	220	nF	±10%, ±20%	0.80	±0.10	±0.10	5.0%		(I)	
	C1608X5R474□FTS	1V, 1kHz	470	nF	±10%, ±20%	0.80	±0.10	±0.10	5.0%		(II)	
	C1608X5R105□FTS	1V, 1kHz	1.0	uF	±10%, ±20%	0.80	±0.15	±0.15	10.0%		(II)	
	C1608X5R225□FTS	1V, 1kHz	2.2	uF	±10%, ±20%	0.80	±0.15	±0.15	10.0%		(II)	
	C1608X5R475□FTS	1V, 1kHz	4.7	uF	±10%, ±20%	0.80	±0.20	±0.20	10.0%		(II)	
	C1608X5R106□FTS	0.5V, 1kHz	10	uF	±20%	0.80	±0.20	±0.20	10.0%		(II)	
16V	C1608X5R104□ETS	1V, 1kHz	100	nF	±10%, ±20%	0.80	±0.10	±0.10	5.0%	Paper, 4kpcs	(I)	
	C1608X5R224□ETS	1V, 1kHz	220	nF	±10%, ±20%	0.80	±0.10	±0.10	5.0%		(I)	
	C1608X5R334□ETS	1V, 1kHz	330	nF	±10%, ±20%	0.80	±0.10	±0.10	5.0%		(I)	
	C1608X5R474□ETS	1V, 1kHz	470	nF	±10%, ±20%	0.80	±0.10	±0.10	3.5%		(II)	
	C1608X5R684□ETS	1V, 1kHz	680	nF	±10%, ±20%	0.80	±0.10	±0.10	7.5%		(II)	
	C1608X5R105□ETS	1V, 1kHz	1.0	uF	±10%, ±20%	0.80	±0.10	±0.10	10.0%		(II)	
	C1608X5R105□ETSQ	0.5V, 1kHz	1.0	uF	±10%, ±20%	0.45	±0.10	±0.05	10.0%		(II)	
	C1608X5R225□ETS	1V, 1kHz	2.2	uF	±10%, ±20%	0.80	±0.10	±0.10	10.0%		(II)	
	C1608X5R475□ETS	1V, 1kHz	4.7	uF	±10%, ±20%	0.80	±0.20	±0.15	10.0%		(II)*	
	C1608X5R106□ETS	1V, 1kHz	10.0	uF	±20%	0.80	±0.20	±0.20	10.0%		(II)*	
	10V	C1608X5R104□DTS	1V, 1kHz	100	nF	±10%, ±20%	0.80	±0.10	±0.10		7.5%	Paper, 4kpcs
C1608X5R224□DTS		1V, 1kHz	220	nF	±10%, ±20%	0.80	±0.10	±0.10	7.5%	(I)		
C1608X5R334□DTS		1V, 1kHz	330	nF	±10%, ±20%	0.80	±0.10	±0.10	7.5%	(I)		
C1608X5R474□DTS		1V, 1kHz	470	nF	±10%, ±20%	0.80	±0.10	±0.10	7.5%	(I)		
C1608X5R684□DTS		1V, 1kHz	680	nF	±10%, ±20%	0.80	±0.10	±0.10	7.5%	(I)		
C1608X5R105□DTS		1V, 1kHz	1.0	uF	±10%, ±20%	0.80	±0.10	±0.10	7.5%	(II)		
C1608X5R105□DTSQ		1V, 1kHz	1.0	uF	±10%, ±20%	0.45	±0.10	±0.05	7.5%	(II)		
C1608X5R225□DTS		1V, 1kHz	2.2	uF	±10%, ±20%	0.80	±0.10	±0.10	10.0%	(II)		
C1608X5R225□DTSQ		0.5V, 1kHz	2.2	uF	±10%, ±20%	0.45	±0.10	±0.05	10.0%	(II)*		
C1608X5R475□DTS		1V, 1kHz	4.7	uF	±10%, ±20%	0.80	±0.15	±0.15	10.0%	(II)		
C1608X5R475□DTSB		1V, 1kHz	4.7	uF	±10%, ±20%	0.50	±0.20	±0.05	10.0%	(II)		
C1608X5R106□DTS		1V, 1kHz	10	uF	±20%	0.80	±0.20	±0.20	10.0%	(II)*		
C1608X5R226□DWS		0.5V, 120Hz	22	uF	±20%	0.80	±0.20	±0.20	10.0%	Embossed, 4kpcs	(II)*	
6.3V		C1608X5R105□CTS	1V, 1kHz	1.0	uF	±10%, ±20%	0.80	±0.10	±0.10	7.5%	Paper, 4kpcs	
	C1608X5R225□CTS	0.5V, 1kHz	2.2	uF	±10%, ±20%	0.80	±0.10	±0.10	10.0%	(II)		
	C1608X5R335□CTS	1V, 1kHz	3.3	uF	±10%	0.80	±0.15	±0.15	10.0%	(II)		
	C1608X5R475□CTS	0.5V, 1kHz	4.7	uF	±10%, ±20%	0.80	±0.10	±0.10	10.0%	(II)		
	C1608X5R106□CTSB	0.5V, 1kHz	10	uF	±20%	0.50	±0.10	±0.10	10.0%	(II)*		
	C1608X5R106□CTS	0.5V, 1kHz	10	uF	±10%, ±20%	0.80	±0.15	±0.15	10.0%	(II)*		
	C1608X5R226□CTSC	0.5V, 120Hz	22	uF	±20%	0.60	±0.20	+0.2/-0.1	10.0%	(II)*		
	C1608X5R226□CPS	0.5V, 120Hz	22	uF	±20%	0.80	±0.20	±0.20	10.0%	Embossed, 4kpcs		(II)*
4V	C1608X5R106□BTS	0.5V, 1kHz	10	uF	±20%	0.80	±0.10	±0.10	10.0%	Paper, 4kpcs	(II)	
	C1608X5R226□BPS	0.5V, 120Hz	22	uF	±20%	0.80	±0.20	±0.20	10.0%	Embossed, 4kpcs	(II)*	
	C1608X5R476□BPS	0.5V, 120Hz	47	uF	±20%	0.80	±0.20	±0.20	12.5%		(II)*	

● C2012X5R Series (EIA0805)

RV	DARFON P/N	Measuring Condition	Capacitance		Available Tolerance	Thick. (mm)	Tolerance(mm)		DF (max.)	Standard Packing	Test Spec.
			Value	Unit			L/W	Thick.			
50V	C2012X5R105□GTS	1V, 1kHz	1.0	uF	±10%, ±20%	0.85	±0.15	±0.15	10.0%	Paper, 4kpcs	(II)
	C2012X5R225□GTS	1V, 1kHz	2.2	uF	±10%, ±20%	0.85	±0.20	±0.15	10.0%		(II)
	C2012X5R105□GPS	1V, 1kHz	1.0	uF	±10%, ±20%	1.25	±0.15	±0.20	10.0%	Embossed, 3kpcs	(II)
	C2012X5R225□GPS	1V, 1kHz	2.2	uF	±10%, ±20%	1.25	±0.15	±0.20	10.0%		(II)
25V	C2012X5R474□FTS	1V, 1kHz	470	nF	±10%, ±20%	0.85	±0.15	±0.15	7.5%	Paper, 4kpcs	(II)
	C2012X5R105□FTS	1V, 1kHz	1.0	uF	±10%, ±20%	0.85	±0.15	±0.10	10.0%		(II)
	C2012X5R105□FPS	1V, 1kHz	1.0	uF	±10%, ±20%	1.25	±0.20	±0.20	10.0%	Embossed, 3kpcs	(I)
	C2012X5R225□FPS	1V, 1kHz	2.2	uF	±10%, ±20%	0.85	±0.20	±0.10	10.0%		Paper, 4kpcs
	C2012X5R225□FPS	1V, 1kHz	2.2	uF	±10%, ±20%	1.25	±0.15	±0.20	10.0%	Embossed, 3kpcs	(II)
	C2012X5R475□FTS	1V, 1kHz	4.7	uF	±10%, ±20%	0.85	±0.20	±0.10	10.0%		Paper, 4kpcs
	C2012X5R475□FPS	1V, 1kHz	4.7	uF	±10%, ±20%	1.25	±0.15	±0.20	10.0%	Embossed, 3kpcs	(II)
	C2012X5R106□FTS	1V, 1kHz	10	uF	±10%, ±20%	0.85	±0.20	±0.10	12.5%		Paper, 4kpcs
	C2012X5R106□FPS	1V, 1kHz	10	uF	±10%, ±20%	1.25	±0.20	±0.20	15.0%	Embossed, 3kpcs	(II)*
	C2012X5R226□FPS	0.5V, 120Hz	22	uF	±20%	1.25	±0.20	±0.20	15.0%		(II)

□ Tolerance Code: J=±5%, K=±10%, M=±20% ;Special tolerance on the request.;

(II)* High temperature load life test are applicable in rated voltage *100%

RV	DARFON P/N	Measuring Condition	Capacitance		Available Tolerance	Thick. (mm)	Tolerance(mm)		DF (max.)	Standard Packing	Test Spec.
			Value	Unit			L/W	Thick.			
16V	C2012X5R105□ ETS	1V, 1kHz	1.0	uF	±10%, ±20%	0.85	±0.15	±0.15	10.0%	Paper, 4kpcs	(II)
	C2012X5R105□ EPS	1V, 1kHz	1.0	uF	±10%, ±20%	1.25	±0.10	±0.20	5.0%	Embossed, 3kpcs	(I)
	C2012X5R225□ EPS	1V, 1kHz	2.2	uF	±10%, ±20%	1.25	±0.10	±0.20	5.0%		(II)
	C2012X5R475□ ETS	0.5V, 1kHz	4.7	uF	±10%, ±20%	0.85	±0.20	±0.10	10.0%	Paper, 4kpcs	(II)
	C2012X5R475□ EPS	1V, 1kHz	4.7	uF	±10%, ±20%	1.25	±0.10	±0.20	7.5%	Embossed, 3kpcs	(II)
	C2012X5R106□ ETS	1V, 1kHz	10	uF	±10%, ±20%	0.85	±0.15	±0.10	10.0%	Paper, 4kpcs	(II)*
	C2012X5R106□ EPS	0.5V, 1kHz	10	uF	±10%, ±20%	1.25	±0.10	±0.20	10.0%	Embossed, 3kpcs	(II)*
	C2012X5R226□ ETS	0.5V, 120Hz	22	uF	±20%	0.85	±0.20	±0.10	10.0%	Paper, 4kpcs	(II)*
10V	C2012X5R226□ EPS	0.5V, 120Hz	22	uF	±20%	1.25	±0.20	±0.20	10.0%	Embossed, 3kpcs	(II)*
	C2012X5R225□ DTS	1V, 1kHz	2.2	uF	±10%, ±20%	0.85	±0.15	±0.10	10.0%	Paper, 4kpcs	(II)
	C2012X5R335□ DPS	1V, 1kHz	3.3	uF	±10%, ±20%	1.25	±0.20	±0.20	10.0%	Embossed, 3kpcs	(II)
	C2012X5R475□ DPS	1V, 1kHz	4.7	uF	±10%, ±20%	1.25	±0.15	±0.20	10.0%		(II)
	C2012X5R106□ DTS	0.5V, 1kHz	10	uF	±10%, ±20%	0.85	±0.20	±0.15	10.0%	Paper, 4kpcs	(II)
	C2012X5R106□ DPS	0.5V, 1kHz	10	uF	±10%, ±20%	1.25	±0.15	±0.20	10.0%	Embossed, 3kpcs	(II)
	C2012X5R226□ DTS	0.5V, 120Hz	22	uF	±20%	0.85	±0.15	±0.15	10.0%	Paper, 4kpcs	(II)*
	C2012X5R226□ DPS	0.5V, 120Hz	22	uF	±20%	1.25	±0.20	±0.20	10.0%	Embossed, 3kpcs	(II)
C2012X5R476□ DPS	0.5V, 120Hz	47	uF	±20%	1.25	±0.20	±0.20	10.0%	(II)*		
6.3V	C2012X5R475□ CPS	0.5V, 1kHz	4.7	uF	±10%, ±20%	1.25	±0.15	±0.20	10.0%	Embossed, 3kpcs	(I)
	C2012X5R106□ CTS	0.5V, 1kHz	10	uF	±10%, ±20%	0.85	±0.20	±0.15	10.0%	Paper, 4kpcs	(II)
	C2012X5R106□ CPS	0.5V, 1kHz	10	uF	±10%, ±20%	1.25	±0.15	±0.20	10.0%	Embossed, 3kpcs	(II)
	C2012X5R226□ CTS	0.5V, 120Hz	22	uF	±20%	0.85	±0.15	±0.15	10.0%	Paper, 4kpcs	(II)
	C2012X5R226□ CPS	0.5V, 120Hz	22	uF	±20%	1.25	±0.15	±0.15	10.0%	Embossed, 3kpcs	(II)
	C2012X5R476□ CTS	0.5V, 120Hz	47	uF	±20%	0.85	±0.20	±0.15	10.0%	Paper, 4kpcs	(II)*
	C2012X5R476□ CPS	0.5V, 120Hz	47	uF	±20%	1.25	±0.20	±0.20	10.0%	Embossed, 3kpcs	(II)*

● C3216X5R Series (EIA1206)

RV	DARFON P/N	Measuring Condition	Capacitance		Available Tolerance	Thick. (mm)	Tolerance(mm)		DF (max.)	Standard Packing	Test Spec.
			Value	Unit			L/W	Thick.			
50V	C3216X5R225□ GTS	1V, 1kHz	2.2	uF	±10%, ±20%	0.85	±0.15	±0.10	10.0%	Paper, 4kpcs	(II)
	C3216X5R475□ GTS	1V, 1kHz	4.7	uF	±10%, ±20%	0.85	±0.15	±0.10	10.0%		(II)
	C3216X5R475□ GPS	1V, 1kHz	4.7	uF	±10%, ±20%	1.60	±0.20	±0.30	10.0%	Embossed, 2kpcs	(II)
	C3216X5R106□ GPS	1V, 1kHz	10.0	uF	±10%, ±20%	1.60	±0.20	±0.20	10.0%		(II)
35V	C3216X5R106□ NTS	1V, 1kHz	10.0	uF	±10%, ±20%	0.85	±0.15	±0.10	10.0%	Paper, 4kpcs	(II)*
	C3216X5R106□ NPS	1V, 1kHz	10	uF	±10%, ±20%	1.60	±0.20	±0.30	10.0%	Embossed, 2kpcs	(II)
25V	C3216X5R225□ FPS	1V, 1kHz	2.2	uF	±10%, ±20%	1.60	±0.20	±0.30	5.0%	Embossed, 2kpcs	(I)
	C3216X5R475□ FPS	1V, 1kHz	4.7	uF	±10%, ±20%	1.60	±0.20	±0.30	5.0%		(I)
	C3216X5R106□ FPS	1V, 1kHz	10	uF	±10%, ±20%	1.60	±0.20	±0.30	10.0%		(II)
	C3216X5R226□ FPS	0.5V, 120Hz	22	uF	±10%, ±20%	1.60	±0.20	±0.30	10.0%		(II)
16V	C3216X5R225□ EPS	1V, 1kHz	2.2	uF	±10%, ±20%	1.60	±0.20	±0.30	5.0%	Embossed, 2kpcs	(I)
	C3216X5R475□ EPS	1V, 1kHz	4.7	uF	±10%, ±20%	1.60	±0.20	±0.30	5.0%		(I)
	C3216X5R106□ EPS	1V, 1kHz	10	uF	±10%, ±20%	1.60	±0.20	±0.30	10.0%		(II)
	C3216X5R226□ EPS	0.5V, 120Hz	22	uF	±10%, ±20%	1.60	±0.20	±0.20	10.0%		(II)
10V	C3216X5R225□ DPS	1V, 1kHz	2.2	uF	±10%, ±20%	1.60	±0.20	±0.30	7.5%	Embossed, 2kpcs	(I)
	C3216X5R475□ DPS	1V, 1kHz	4.7	uF	±10%, ±20%	1.60	±0.20	±0.30	7.5%		(I)
	C3216X5R106□ DPS	1V, 1kHz	10	uF	±10%, ±20%	1.60	±0.20	±0.30	10.0%		(II)
	C3216X5R226□ DPS	0.5V, 120Hz	22	uF	±10%, ±20%	1.60	±0.20	±0.30	10.0%		(II)
	C3216X5R476MDPS	0.5V, 120Hz	47	uF	±20%	1.60	±0.20	±0.30	10.0%		(II)
6.3V	C3216X5R226□ CPS	0.5V, 120Hz	22	uF	±10%, ±20%	1.60	±0.20	±0.30	15.0%	Embossed, 2kpcs	(II)
	C3216X5R476MCPS	0.5V, 120Hz	47	uF	±20%	1.60	±0.20	±0.20	10.0%		(II)
4V	C3216X5R107MCPS	0.5V, 120Hz	100	uF	±20%	1.60	±0.30	±0.30	15.0%	Embossed, 2kpcs	(II)
	C3216X5R226□ BPS	0.5V, 120Hz	22	uF	±10%, ±20%	1.60	±0.20	±0.30	15.0%		(II)
	C3216X5R476MBPS	0.5V, 120Hz	47	uF	±20%	1.60	±0.20	±0.30	15.0%		(II)
	C3216X5R107MBPS	0.5V, 120Hz	100	uF	±20%	1.60	±0.30	±0.30	15.0%	Embossed, 2kpcs	(II)

● C3225X5R Series (EIA1210)

RV	DARFON P/N	Measuring Condition	Capacitance		Available Tolerance	Thick. (mm)	Tolerance(mm)		DF (max.)	Standard Packing	Test Spec.
			Value	Unit			L/W	Thick.			
50V	C3225X5R106□GPS	1V , 1kHz	10	uF	±10% , ±20%	2.50	±0.30/±0.20	±0.20	5.0%	Embossed, 1kpcs	(II)
35V	C3225X5R106□NPS	1V , 1kHz	10	uF	±10% , ±20%	2.50	±0.30/±0.20	±0.20	5.0%	Embossed, 1kpcs	(I)
25V	C3225X5R475□FPS	1V , 1kHz	4.7	uF	±10% , ±20%	2.00	±0.30/±0.20	±0.20	10.0%	Embossed, 2kpcs	(I)
	C3225X5R106□FPS	1V , 1kHz	10	uF	±10% , ±20%	2.00	±0.30/±0.20	±0.20	10.0%		(I)
	C3225X5R226□FPS	0.5V , 120Hz	22	uF	±10% , ±20%	2.50	±0.30/±0.20	±0.20	10.0%	Embossed, 1kpcs	(II)
16V	C3225X5R475□EPS	1V , 1kHz	4.7	uF	±10% , ±20%	2.00	±0.30/±0.20	±0.20	5.0%	Embossed, 2kpcs	(I)
	C3225X5R106□EPS	1V , 1kHz	10	uF	±10% , ±20%	2.00	±0.30/±0.20	±0.20	5.0%		(I)
	C3225X5R226□EPS	0.5V , 120Hz	22	uF	±10% , ±20%	2.50	±0.30/±0.20	±0.20	15.0%	Embossed, 1kpcs	(II)
	C3225X5R476□EPS	0.5V , 120Hz	47	uF	±10% , ±20%	2.50	±0.30/±0.20	±0.20	15.0%		(II)
10V	C3225X5R226□DPS	0.5V , 120Hz	22	uF	±10% , ±20%	2.50	±0.30/±0.20	±0.20	10.0%	Embossed, 1kpcs	(II)
	C3225X5R476□DPS	0.5V , 120Hz	47	uF	±10% , ±20%	2.50	±0.30/±0.20	±0.20	10.0%		(II)
	C3225X5R107MDPS	0.5V , 120Hz	100	uF	±20%	2.50	±0.30/±0.20	±0.30	10.0%		(II)
6.3V	C3225X5R226□CPS	0.5V , 120Hz	22	uF	±10% , ±20%	2.50	±0.30/±0.20	±0.20	10.0%	Embossed, 1kpcs	(II)
	C3225X5R476□CPS	0.5V , 120Hz	47	uF	±10% , ±20%	2.50	±0.30/±0.20	±0.20	15.0%		(II)
	C3225X5R107MCPS	0.5V , 120Hz	100	uF	±20%	2.50	±0.30	±0.30	15.0%		(II)

□ Tolerance Code: K=±10%, M=±20% ;Special tolerance on the request.;

(II)* High temperature load life test are applicable in rated voltage *100%

- X6S Series
- C0603X6S Series (EIA0201)

RV	DARFON P/N	Measuring Condition	Capacitance		Available Tolerance	Thick. (mm)	Tolerance(mm)		DF (max.)	Standard Packing	Test Spec.
			Value	Unit			L/W	Thick.			
6.3V	C0603X6S103□CTS	0.5V , 1kHz	10	nF	±10%, ±20%	0.30	± 0.03	±0.03	5.0%	Paper, 15kpcs	(I)
	C0603X6S104□CTS	0.5V , 1kHz	100	nF	±10%, ±20%	0.30	± 0.03	±0.03	10.0%		(II)*
	C0603X6S224□CTS	0.5V , 1kHz	220	nF	±20%	0.30	± 0.03	±0.03	10.0%		(II)*
4V	C0603X6S104□BTS	0.5V , 1kHz	100	nF	±10%, ±20%	0.30	± 0.03	±0.03	10.0%		(II)
	C0603X6S224□BTS	0.5V , 1kHz	220	nF	±20%	0.30	± 0.03	±0.03	10.0%		(II)
	C0603X6S105MBTS	0.5V , 1kHz	1	uF	±20%	0.30	± 0.03	±0.03	10.0%		(II)*

- C1005X6S Series (EIA0402)

RV	DARFON P/N	Measuring Condition	Capacitance		Available Tolerance	Thick. (mm)	Tolerance(mm)		DF (max.)	Standard Packing	Test Spec.
			Value	Unit			L/W	Thick.			
16V	C1005X6S105□ETS	0.5V , 1kHz	1.0	uF	±10%, ±20%	0.50	±0.10	±0.10	12.5%	Paper, 10kpcs	(II)*
10V	C1005X6S105□DTS	0.5V , 1kHz	1.0	uF	±10%, ±20%	0.50	±0.05	±0.05	12.5%		(II)*
6.3V	C1005X6S105□CTS	0.5V , 1kHz	1.0	uF	±10%, ±20%	0.50	±0.05	±0.05	10.0%		(II)*
	C1005X6S225□CTS	0.5V , 1kHz	2.2	uF	±20%	0.50	±0.05	±0.05	10.0%		(II)*
	C1005X6S475□CTS	0.5V , 1kHz	4.7	uF	±20%	0.50	±0.05	±0.05	10.0%		(II)*

- C1608X6S Series (EIA0603)

RV	DARFON P/N	Measuring Condition	Capacitance		Available Tolerance	Thick. (mm)	Tolerance(mm)		DF (max.)	Standard Packing	Test Spec.
			Value	Unit			L/W	Thick.			
10V	C1608X6S106□DTS	1V , 1kHz	10	uF	±20%	0.80	±0.20	±0.20	10.0%	Paper, 4kpcs	(II)
6.3V	C1608X6S475□CTS	0.5V , 1kHz	4.7	uF	±20%	0.80	±0.10	±0.10	10.0%		(II)*
	C1608X6S106□CTS	0.5V , 120Hz	10	uF	±20%	0.80	±0.20	±0.20	10.0%		(II)
	C1608X6S226□CTS	0.5V , 120Hz	22	uF	±20%	0.80	±0.20	±0.20	10.0%		(II)*

- C2012X6S Series (EIA0805)

RV	DARFON P/N	Measuring Condition	Capacitance		Available Tolerance	Thick. (mm)	Tolerance(mm)		DF (max.)	Standard Packing	Test Spec.
			Value	Unit			L/W	Thick.			
25V	C2012X6S106□FPS	0.5V , 1kHz	10	uF	±10%	1.25	±0.15	±0.15	12.5%	Embossed, 3kpcs	(II)*
16V	C2012X6S106□EPS	0.5V , 1kHz	10	uF	±10%	1.25	±0.15	±0.15	10.0%		(II)*
6.3V	C2012X6S226□CPS	0.5V , 120Hz	22	uF	±20%	1.25	±0.15	±0.15	10.0%		(II)*
4V	C2012X6S226□BPS	0.5V , 120Hz	22	uF	±20%	1.25	±0.15	±0.15	10.0%		(II)
	C2012X6S476□BPS	0.5V , 120Hz	47	uF	±20%	1.25	±0.20	±0.20	10.0%		(II)*

- C3216X6S Series (EIA1206)

RV	DARFON P/N	Measuring Condition	Capacitance		Available Tolerance	Thick. (mm)	Tolerance(mm)		DF (max.)	Standard Packing	Test Spec.
			Value	Unit			L/W	Thick.			
6.3V	C3216X6S476□CPS	0.5V , 120Hz	47	uF	±20%	1.60	±0.20	±0.20	10.0%	Embossed, 2kpcs	(II)
4V	C3216X6S226□BTS	0.5V , 120Hz	22	uF	±20%	0.85	±0.20	±0.10	10.0%	Paper, 4kpcs	(II)

■ X7R Series

● C0603X7R Series(EIA0201)

RV	DARFON P/N	Measuring Condition	Capacitance		Available Tolerance	Thick. (mm)	Tolerance(mm)		DF (max.)	Standard Packing	Test Spec.
			Value	Unit			L/W	Thick.			
50V	C0603X7R101□GTS	1V, 1kHz	100	pF	±10%, ±5%	0.30	± 0.03	± 0.03	3.0%	Paper, 15Kpcs	(I)
	C0603X7R121□GTS	1V, 1kHz	120	pF	±10%	0.30	± 0.03	± 0.03	3.0%		(I)
	C0603X7R151□GTS	1V, 1kHz	150	pF	±10%	0.30	± 0.03	± 0.03	3.0%		(I)
	C0603X7R181□GTS	1V, 1kHz	180	pF	±10%	0.30	± 0.03	± 0.03	3.0%		(I)
	C0603X7R221□GTS	1V, 1kHz	220	pF	±10%	0.30	± 0.03	± 0.03	3.0%		(I)
	C0603X7R271□GTS	1V, 1kHz	270	pF	±10%	0.30	± 0.03	± 0.03	3.0%		(I)
	C0603X7R331□GTS	1V, 1kHz	330	pF	±10%	0.30	± 0.03	± 0.03	3.0%		(I)
	C0603X7R391□GTS	1V, 1kHz	390	pF	±10%	0.30	± 0.03	± 0.03	3.0%		(I)
	C0603X7R471□GTS	1V, 1kHz	470	pF	±10%	0.30	± 0.03	± 0.03	3.0%		(I)
	C0603X7R561□GTS	1V, 1kHz	560	pF	±10%	0.30	± 0.03	± 0.03	3.0%		(I)
	C0603X7R681□GTS	1V, 1kHz	680	pF	±10%	0.30	± 0.03	± 0.03	3.0%		(I)
	C0603X7R821□GTS	1V, 1kHz	820	pF	±10%	0.30	± 0.03	± 0.03	3.0%		(I)
	C0603X7R102□GTS	1V, 1kHz	1.0	nF	±10%	0.30	± 0.03	± 0.03	3.0%		(I)
	C0603X7R122□GTS	1V, 1kHz	1.2	nF	±10%	0.30	± 0.03	± 0.03	3.0%		(I)
C0603X7R152□GTS	1V, 1kHz	1.5	nF	±10%	0.30	± 0.03	± 0.03	3.0%	(I)		
C0603X7R182□GTS	1V, 1kHz	1.8	nF	±10%	0.30	± 0.03	± 0.03	3.0%	(I)		
C0603X7R222□GTS	1V, 1kHz	2.2	nF	±10%	0.30	± 0.03	± 0.03	3.0%	(I)		
25V	C0603X7R101□FTS	1V, 1kHz	100	pF	±10%	0.30	± 0.03	± 0.03	3.5%	Paper, 15Kpcs	(I)
	C0603X7R121□FTS	1V, 1kHz	120	pF	±10%	0.30	± 0.03	± 0.03	3.5%		(I)
	C0603X7R151□FTS	1V, 1kHz	150	pF	±10%	0.30	± 0.03	± 0.03	3.5%		(I)
	C0603X7R181□FTS	1V, 1kHz	180	pF	±10%	0.30	± 0.03	± 0.03	3.5%		(I)
	C0603X7R221□FTS	1V, 1kHz	220	pF	±10%	0.30	± 0.03	± 0.03	3.5%		(I)
	C0603X7R271□FTS	1V, 1kHz	270	pF	±10%	0.30	± 0.03	± 0.03	3.5%		(I)
	C0603X7R331□FTS	1V, 1kHz	330	pF	±10%	0.30	± 0.03	± 0.03	3.5%		(I)
	C0603X7R391□FTS	1V, 1kHz	390	pF	±10%	0.30	± 0.03	± 0.03	3.5%		(I)
	C0603X7R471□FTS	1V, 1kHz	470	pF	±10%	0.30	± 0.03	± 0.03	3.5%		(I)
	C0603X7R561□FTS	1V, 1kHz	560	pF	±10%	0.30	± 0.03	± 0.03	3.5%		(I)
	C0603X7R681□FTS	1V, 1kHz	680	pF	±10%	0.30	± 0.03	± 0.03	3.5%		(I)
	C0603X7R821□FTS	1V, 1kHz	820	pF	±10%	0.30	± 0.03	± 0.03	3.5%		(I)
	C0603X7R102□FTS	1V, 1kHz	1.0	nF	±10%	0.30	± 0.03	± 0.03	3.5%		(I)
	C0603X7R122□FTS	1V, 1kHz	1.2	nF	±10%	0.30	± 0.03	± 0.03	3.5%		(I)
C0603X7R152□FTS	1V, 1kHz	1.5	nF	±10%	0.30	± 0.03	± 0.03	3.5%	(I)		
C0603X7R182□FTS	1V, 1kHz	1.8	nF	±10%	0.30	± 0.03	± 0.03	3.5%	(I)		
C0603X7R222□FTS	1V, 1kHz	2.2	nF	±10%	0.30	± 0.03	± 0.03	3.5%	(I)		
16V	C0603X7R221□ETS	1V, 1kHz	220	pF	±10%	0.30	± 0.03	± 0.03	3.5%	Paper, 15Kpcs	(I)
	C0603X7R331□ETS	1V, 1kHz	330	pF	±10%	0.30	± 0.03	± 0.03	3.5%		(I)
	C0603X7R102□ETS	1V, 1kHz	1.0	nF	±10%	0.30	± 0.03	± 0.03	3.5%		(I)
	C0603X7R272□ETS	1V, 1kHz	2.7	nF	±10%	0.30	± 0.03	± 0.03	5.0%		(I)
	C0603X7R332□ETS	1V, 1kHz	3.3	nF	±10%	0.30	± 0.03	± 0.03	5.0%		(I)
	C0603X7R392□ETS	1V, 1kHz	3.9	nF	±10%	0.30	± 0.03	± 0.03	5.0%		(I)
	C0603X7R472□ETS	1V, 1kHz	4.7	nF	±10%	0.30	± 0.03	± 0.03	5.0%		(I)
	C0603X7R562□ETS	1V, 1kHz	5.6	nF	±10%	0.30	± 0.03	± 0.03	5.0%		(I)
	C0603X7R682□ETS	1V, 1kHz	6.8	nF	±10%	0.30	± 0.03	± 0.03	5.0%		(I)
10V	C0603X7R822□ETS	1V, 1kHz	8.2	nF	±10%	0.30	± 0.03	± 0.03	5.0%	(I)	
	C0603X7R103□ETS	1V, 1kHz	10	nF	±10%	0.30	± 0.03	± 0.03	5.0%	(I)	
	C0603X7R182□DTS	1V, 1kHz	1.8	nF	±10%	0.30	± 0.03	± 0.03	5.0%	(I)	
	C0603X7R272□DTS	1V, 1kHz	2.7	nF	±10%	0.30	± 0.03	± 0.03	5.0%	(I)	
	C0603X7R332□DTS	1V, 1kHz	3.3	nF	±10%	0.30	± 0.03	± 0.03	5.0%	(I)	
	C0603X7R392□DTS	1V, 1kHz	3.9	nF	±10%	0.30	± 0.03	± 0.03	5.0%	(I)	
	C0603X7R472□DTS	1V, 1kHz	4.7	nF	±10%	0.30	± 0.03	± 0.03	5.0%	(I)	
	C0603X7R562□DTS	1V, 1kHz	5.6	nF	±10%	0.30	± 0.03	± 0.03	5.0%	(I)	
C0603X7R682□DTS	1V, 1kHz	6.8	nF	±10%	0.30	± 0.03	± 0.03	5.0%	(I)		
C0603X7R822□DTS	1V, 1kHz	8.2	nF	±10%	0.30	± 0.03	± 0.03	5.0%	(I)		
C0603X7R103□DTS	1V, 1kHz	10	nF	±10%	0.30	± 0.03	± 0.03	5.0%	(I)		

□ Tolerance Code: J=±5%, K=±10%, M=±20%; Special tolerance on the request.

(II)* High temperature load life test are applicable in rated voltage *100%

● C1005X7R Series (EIA0402)

RV	DARFON P/N	Measuring Condition	Capacitance		Available Tolerance	Thick. (mm)	Tolerance(mm)		DF (max.)	Standard Packing	Test Spec.
			Value	Unit			L/W	Thick.			
50V	C1005X7R101□GTS	1V, 1kHz	100	pF	±10%	0.50	±0.05	±0.05	3.0%	Paper, 10Kpcs	(I)
	C1005X7R121□GTS	1V, 1kHz	120	pF	±10%	0.50	±0.05	±0.05	3.0%		(I)
	C1005X7R151□GTS	1V, 1kHz	150	pF	±10%	0.50	±0.05	±0.05	3.0%		(I)
	C1005X7R181□GTS	1V, 1kHz	180	pF	±10%	0.50	±0.05	±0.05	3.0%		(I)
	C1005X7R221□GTS	1V, 1kHz	220	pF	±10%	0.50	±0.05	±0.05	3.0%		(I)
	C1005X7R271□GTS	1V, 1kHz	270	pF	±10%	0.50	±0.05	±0.05	3.0%		(I)
	C1005X7R331□GTS	1V, 1kHz	330	pF	±10%	0.50	±0.05	±0.05	3.0%		(I)
	C1005X7R391□GTS	1V, 1kHz	390	pF	±10%	0.50	±0.05	±0.05	3.0%		(I)
	C1005X7R471□GTS	1V, 1kHz	470	pF	±10%	0.50	±0.05	±0.05	3.0%		(I)
	C1005X7R561□GTS	1V, 1kHz	560	pF	±10%	0.50	±0.05	±0.05	3.0%		(I)
	C1005X7R681□GTS	1V, 1kHz	680	pF	±10%	0.50	±0.05	±0.05	3.0%		(I)
	C1005X7R821□GTS	1V, 1kHz	820	pF	±10%	0.50	±0.05	±0.05	3.0%		(I)
	C1005X7R102□GTS	1V, 1kHz	1.0	nF	±10%, ±5%	0.50	±0.05	±0.05	3.0%		(I)
	C1005X7R122□GTS	1V, 1kHz	1.2	nF	±10%	0.50	±0.05	±0.05	3.0%		(I)
	C1005X7R152□GTS	1V, 1kHz	1.5	nF	±10%	0.50	±0.05	±0.05	3.0%		(I)
	C1005X7R182□GTS	1V, 1kHz	1.8	nF	±10%	0.50	±0.05	±0.05	3.0%		(I)
	C1005X7R222□GTS	1V, 1kHz	2.2	nF	±10%	0.50	±0.05	±0.05	3.0%		(I)
	C1005X7R272□GTS	1V, 1kHz	2.7	nF	±10%	0.50	±0.05	±0.05	3.0%		(I)
	C1005X7R332□GTS	1V, 1kHz	3.3	nF	±10%	0.50	±0.05	±0.05	3.0%		(I)
	C1005X7R392□GTS	1V, 1kHz	3.9	nF	±10%	0.50	±0.05	±0.05	3.0%		(I)
	C1005X7R472□GTS	1V, 1kHz	4.7	nF	±10%	0.50	±0.05	±0.05	3.0%		(I)
	C1005X7R562□GTS	1V, 1kHz	5.6	nF	±10%	0.50	±0.05	±0.05	3.0%		(I)
	C1005X7R682□GTS	1V, 1kHz	6.8	nF	±10%	0.50	±0.05	±0.05	3.0%		(I)
	C1005X7R822□GTS	1V, 1kHz	8.2	nF	±10%	0.50	±0.05	±0.05	3.0%		(I)
	C1005X7R103□GTS	1V, 1kHz	10	nF	±10%	0.50	±0.05	±0.05	3.0%		(I)
	C1005X7R123□GTS	1V, 1kHz	12	nF	±10%	0.50	±0.05	±0.05	3.0%		(I)
	C1005X7R153□GTS	1V, 1kHz	15	nF	±10%	0.50	±0.05	±0.05	3.0%		(I)
	C1005X7R223□GTS	1V, 1kHz	22	nF	±10%	0.50	±0.05	±0.05	3.0%		(I)
	C1005X7R473□GTS	1V, 1kHz	47	nF	±10%	0.50	±0.05	±0.05	10.0%		(II)
	C1005X7R563□GTS	1V, 1kHz	56	nF	±10%	0.50	±0.05	±0.05	10.0%		(II)
C1005X7R683□GTS	1V, 1kHz	68	nF	±10%	0.50	±0.05	±0.05	10.0%	(II)		
C1005X7R823□GTS	1V, 1kHz	82	nF	±10%	0.50	±0.05	±0.05	10.0%	(II)		
C1005X7R104□GTS	1V, 1kHz	100	nF	±10%	0.50	±0.05	±0.05	10.0%	(II)		
25V	C1005X7R101□FTS	1V, 1kHz	100	pF	±10%	0.50	±0.05	±0.05	3.0%	Paper, 10Kpcs	(I)
	C1005X7R121□FTS	1V, 1kHz	120	pF	±10%	0.50	±0.05	±0.05	3.0%		(I)
	C1005X7R151□FTS	1V, 1kHz	150	pF	±10%	0.50	±0.05	±0.05	3.0%		(I)
	C1005X7R181□FTS	1V, 1kHz	180	pF	±10%	0.50	±0.05	±0.05	3.0%		(I)
	C1005X7R221□FTS	1V, 1kHz	220	pF	±10%	0.50	±0.05	±0.05	3.0%		(I)
	C1005X7R271□FTS	1V, 1kHz	270	pF	±10%	0.50	±0.05	±0.05	3.0%		(I)
	C1005X7R331□FTS	1V, 1kHz	330	pF	±10%	0.50	±0.05	±0.05	3.0%		(I)
	C1005X7R391□FTS	1V, 1kHz	390	pF	±10%	0.50	±0.05	±0.05	3.0%		(I)
	C1005X7R471□FTS	1V, 1kHz	470	pF	±10%	0.50	±0.05	±0.05	3.0%		(I)
	C1005X7R561□FTS	1V, 1kHz	560	pF	±10%	0.50	±0.05	±0.05	3.0%		(I)
	C1005X7R681□FTS	1V, 1kHz	680	pF	±10%	0.50	±0.05	±0.05	3.0%		(I)
	C1005X7R821□FTS	1V, 1kHz	820	pF	±10%	0.50	±0.05	±0.05	3.0%		(I)
	C1005X7R102□FTS	1V, 1kHz	1.0	nF	±10%	0.50	±0.05	±0.05	3.0%		(I)
	C1005X7R122□FTS	1V, 1kHz	1.2	nF	±10%	0.50	±0.05	±0.05	3.0%		(I)
	C1005X7R152□FTS	1V, 1kHz	1.5	nF	±10%	0.50	±0.05	±0.05	3.0%		(I)
	C1005X7R182□FTS	1V, 1kHz	1.8	nF	±10%	0.50	±0.05	±0.05	3.0%		(I)
	C1005X7R222□FTS	1V, 1kHz	2.2	nF	±10%	0.50	±0.05	±0.05	3.0%		(I)
	C1005X7R272□FTS	1V, 1kHz	2.7	nF	±10%	0.50	±0.05	±0.05	3.0%		(I)
	C1005X7R332□FTS	1V, 1kHz	3.3	nF	±10%	0.50	±0.05	±0.05	3.0%		(I)
	C1005X7R392□FTS	1V, 1kHz	3.9	nF	±10%	0.50	±0.05	±0.05	3.0%		(I)
	C1005X7R472□FTS	1V, 1kHz	4.7	nF	±10%	0.50	±0.05	±0.05	3.0%		(I)
	C1005X7R562□FTS	1V, 1kHz	5.6	nF	±10%	0.50	±0.05	±0.05	3.0%		(I)
	C1005X7R682□FTS	1V, 1kHz	6.8	nF	±10%	0.50	±0.05	±0.05	3.0%		(I)
	C1005X7R822□FTS	1V, 1kHz	8.2	nF	±10%	0.50	±0.05	±0.05	3.0%		(I)
	C1005X7R103□FTS	1V, 1kHz	10	nF	±10%	0.50	±0.05	±0.05	3.0%		(I)
	C1005X7R123□FTS	1V, 1kHz	12	nF	±10%	0.50	±0.05	±0.05	3.0%		(I)
	C1005X7R153□FTS	1V, 1kHz	15	nF	±10%	0.50	±0.05	±0.05	3.0%		(I)
	C1005X7R183□FTS	1V, 1kHz	18	nF	±10%	0.50	±0.05	±0.05	3.0%		(I)
	C1005X7R223□FTS	1V, 1kHz	22	nF	±10%	0.50	±0.05	±0.05	3.0%		(I)

MLCC
General Purpose

RV	DARFON P/N	Measuring Condition	Capacitance		Available Tolerance	Thick. (mm)	Tolerance(mm)		DF (max.)	Standard Packing	Test Spec.
			Value	Unit			L/W	Thick.			
25V	C1005X7R273□ FTS	1V, 1kHz	27	nF	±10%	0.50	±0.05	±0.05	3.5%	Paper, 10Kpcs	(I)
	C1005X7R333□ FTS	1V, 1kHz	33	nF	±10%	0.50	±0.05	±0.05	3.5%		(I)
	C1005X7R473□ FTS	1V, 1kHz	47	nF	±10%	0.50	±0.05	±0.05	3.5%		(I)
	C1005X7R563□ FTS	1V, 1kHz	56	nF	±10%	0.50	±0.05	±0.05	3.5%		(I)
	C1005X7R683□ FTS	1V, 1kHz	68	nF	±10%	0.50	±0.05	±0.05	3.5%		(I)
	C1005X7R104□ FTS	1V, 1kHz	100	nF	±10%	0.50	±0.05	±0.05	10.0%		(II)
16V	C1005X7R224□ FTS	1V, 1kHz	220	nF	±10%	0.50	±0.05	±0.05	10.0%	Paper, 10Kpcs	(II)
	C1005X7R101□ ETS	1V, 1kHz	100	pF	±10%	0.50	±0.05	±0.05	5.0%		(I)
	C1005X7R121□ ETS	1V, 1kHz	120	pF	±10%	0.50	±0.05	±0.05	5.0%		(I)
	C1005X7R151□ ETS	1V, 1kHz	150	pF	±10%	0.50	±0.05	±0.05	5.0%		(I)
	C1005X7R181□ ETS	1V, 1kHz	180	pF	±10%	0.50	±0.05	±0.05	5.0%		(I)
	C1005X7R221□ ETS	1V, 1kHz	220	pF	±10%	0.50	±0.05	±0.05	5.0%		(I)
	C1005X7R271□ ETS	1V, 1kHz	270	pF	±10%	0.50	±0.05	±0.05	5.0%		(I)
	C1005X7R331□ ETS	1V, 1kHz	330	pF	±10%	0.50	±0.05	±0.05	5.0%		(I)
	C1005X7R391□ ETS	1V, 1kHz	390	pF	±10%	0.50	±0.05	±0.05	5.0%		(I)
	C1005X7R471□ ETS	1V, 1kHz	470	pF	±10%	0.50	±0.05	±0.05	5.0%		(I)
	C1005X7R561□ ETS	1V, 1kHz	560	pF	±10%	0.50	±0.05	±0.05	5.0%		(I)
	C1005X7R681□ ETS	1V, 1kHz	680	pF	±10%	0.50	±0.05	±0.05	5.0%		(I)
	C1005X7R821□ ETS	1V, 1kHz	820	pF	±10%	0.50	±0.05	±0.05	5.0%		(I)
	C1005X7R102□ ETS	1V, 1kHz	1.0	nF	±10%	0.50	±0.05	±0.05	5.0%		(I)
	C1005X7R122□ ETS	1V, 1kHz	1.2	nF	±10%	0.50	±0.05	±0.05	5.0%		(I)
	C1005X7R152□ ETS	1V, 1kHz	1.5	nF	±10%	0.50	±0.05	±0.05	5.0%		(I)
	C1005X7R182□ ETS	1V, 1kHz	1.8	nF	±10%	0.50	±0.05	±0.05	5.0%		(I)
	C1005X7R222□ ETS	1V, 1kHz	2.2	nF	±10%	0.50	±0.05	±0.05	5.0%		(I)
	C1005X7R272□ ETS	1V, 1kHz	2.7	nF	±10%	0.50	±0.05	±0.05	5.0%		(I)
	C1005X7R332□ ETS	1V, 1kHz	3.3	nF	±10%	0.50	±0.05	±0.05	5.0%		(I)
	C1005X7R392□ ETS	1V, 1kHz	3.9	nF	±10%	0.50	±0.05	±0.05	5.0%		(I)
	C1005X7R472□ ETS	1V, 1kHz	4.7	nF	±10%	0.50	±0.05	±0.05	5.0%		(I)
	C1005X7R562□ ETS	1V, 1kHz	5.6	nF	±10%	0.50	±0.05	±0.05	5.0%		(I)
	C1005X7R682□ ETS	1V, 1kHz	6.8	nF	±10%	0.50	±0.05	±0.05	5.0%		(I)
	C1005X7R822□ ETS	1V, 1kHz	8.2	nF	±10%	0.50	±0.05	±0.05	5.0%		(I)
	C1005X7R103□ ETS	1V, 1kHz	10	nF	±10%	0.50	±0.05	±0.05	5.0%		(I)
	C1005X7R123□ ETS	1V, 1kHz	12	nF	±10%	0.50	±0.05	±0.05	5.0%		(I)
	C1005X7R153□ ETS	1V, 1kHz	15	nF	±10%	0.50	±0.05	±0.05	5.0%		(I)
	C1005X7R183□ ETS	1V, 1kHz	18	nF	±10%	0.50	±0.05	±0.05	5.0%		(I)
	C1005X7R223□ ETS	1V, 1kHz	22	nF	±10%	0.50	±0.05	±0.05	5.0%		(I)
	C1005X7R273□ ETS	1V, 1kHz	27	nF	±10%	0.50	±0.05	±0.05	5.0%		(I)
	C1005X7R333□ ETS	1V, 1kHz	33	nF	±10%	0.50	±0.05	±0.05	5.0%		(I)
	C1005X7R393□ ETS	1V, 1kHz	39	nF	±10%	0.50	±0.05	±0.05	5.0%		(I)
	C1005X7R473□ ETS	1V, 1kHz	47	nF	±10%	0.50	±0.05	±0.05	5.0%		(I)
C1005X7R563□ ETS	1V, 1kHz	56	nF	±10%	0.50	±0.05	±0.05	5.0%	(I)		
C1005X7R683□ ETS	1V, 1kHz	68	nF	±10%	0.50	±0.05	±0.05	5.0%	(I)		
C1005X7R823□ ETS	1V, 1kHz	82	nF	±10%	0.50	±0.05	±0.05	5.0%	(I)		
C1005X7R104□ ETS	1V, 1kHz	100	nF	±10%	0.50	±0.05	±0.05	5.0%	(I)		
C1005X7R224□ ETS	1V, 1kHz	220	nF	±10%	0.50	±0.05	±0.05	10.0%	(II)		
10V	C1005X7R101□ DTS	1V, 1kHz	100	pF	±10%	0.50	±0.05	±0.05	5.0%	Paper, 10kpcs	(I)
	C1005X7R121□ DTS	1V, 1kHz	120	pF	±10%	0.50	±0.05	±0.05	5.0%		(I)
	C1005X7R151□ DTS	1V, 1kHz	150	pF	±10%	0.50	±0.05	±0.05	5.0%		(I)
	C1005X7R181□ DTS	1V, 1kHz	180	pF	±10%	0.50	±0.05	±0.05	5.0%		(I)
	C1005X7R221□ DTS	1V, 1kHz	220	pF	±10%	0.50	±0.05	±0.05	5.0%		(I)
	C1005X7R271□ DTS	1V, 1kHz	270	pF	±10%	0.50	±0.05	±0.05	5.0%		(I)
	C1005X7R331□ DTS	1V, 1kHz	330	pF	±10%	0.50	±0.05	±0.05	5.0%		(I)
	C1005X7R391□ DTS	1V, 1kHz	390	pF	±10%	0.50	±0.05	±0.05	5.0%		(I)
	C1005X7R471□ DTS	1V, 1kHz	470	pF	±10%	0.50	±0.05	±0.05	5.0%		(I)
	C1005X7R561□ DTS	1V, 1kHz	560	pF	±10%	0.50	±0.05	±0.05	5.0%		(I)
	C1005X7R681□ DTS	1V, 1kHz	680	pF	±10%	0.50	±0.05	±0.05	5.0%		(I)
	C1005X7R821□ DTS	1V, 1kHz	820	pF	±10%	0.50	±0.05	±0.05	5.0%		(I)
	C1005X7R102□ DTS	1V, 1kHz	1.0	nF	±10%	0.50	±0.05	±0.05	5.0%		(I)
	C1005X7R122□ DTS	1V, 1kHz	1.2	nF	±10%	0.50	±0.05	±0.05	5.0%		(I)
C1005X7R152□ DTS	1V, 1kHz	1.5	nF	±10%	0.50	±0.05	±0.05	5.0%	(I)		
C1005X7R182□ DTS	1V, 1kHz	1.8	nF	±10%	0.50	±0.05	±0.05	5.0%	(I)		

□ Tolerance Code: J=±5%, K=±10%, M=±20%; Special tolerance on the request.

(II)* High temperature load life test are applicable in rated voltage *100%

RV	DARFON P/N	Measuring Condition	Capacitance		Available Tolerance	Thick. (mm)	Tolerance(mm)		DF (max.)	Standard Packing	Test Spec.
			Value	Unit			L/W	Thick.			
10V	C1005X7R222□ DTS	1V, 1kHz	2.2	nF	±10%	0.50	±0.05	±0.05	5.0%	Paper, 10kpcs	(I)
	C1005X7R272□ DTS	1V, 1kHz	2.7	nF	±10%	0.50	±0.05	±0.05	5.0%		(I)
	C1005X7R332□ DTS	1V, 1kHz	3.3	nF	±10%	0.50	±0.05	±0.05	5.0%		(I)
	C1005X7R392□ DTS	1V, 1kHz	3.9	nF	±10%	0.50	±0.05	±0.05	5.0%		(I)
	C1005X7R472□ DTS	1V, 1kHz	4.7	nF	±10%	0.50	±0.05	±0.05	5.0%		(I)
	C1005X7R562□ DTS	1V, 1kHz	5.6	nF	±10%	0.50	±0.05	±0.05	5.0%		(I)
	C1005X7R682□ DTS	1V, 1kHz	6.8	nF	±10%	0.50	±0.05	±0.05	5.0%		(I)
	C1005X7R822□ DTS	1V, 1kHz	8.2	nF	±10%	0.50	±0.05	±0.05	5.0%		(I)
	C1005X7R103□ DTS	1V, 1kHz	10	nF	±10%	0.50	±0.05	±0.05	5.0%		(I)
	C1005X7R123□ DTS	1V, 1kHz	12	nF	±10%	0.50	±0.05	±0.05	5.0%		(I)
	C1005X7R153□ DTS	1V, 1kHz	15	nF	±10%	0.50	±0.05	±0.05	5.0%		(I)
	C1005X7R183□ DTS	1V, 1kHz	18	nF	±10%	0.50	±0.05	±0.05	5.0%		(I)
	C1005X7R223□ DTS	1V, 1kHz	22	nF	±10%	0.50	±0.05	±0.05	5.0%		(I)
	C1005X7R273□ DTS	1V, 1kHz	27	nF	±10%	0.50	±0.05	±0.05	5.0%		(I)
	C1005X7R333□ DTS	1V, 1kHz	33	nF	±10%	0.50	±0.05	±0.05	5.0%		(I)
	C1005X7R393□ DTS	1V, 1kHz	39	nF	±10%	0.50	±0.05	±0.05	5.0%		(I)
	C1005X7R473□ DTS	1V, 1kHz	47	nF	±10%	0.50	±0.05	±0.05	5.0%		(I)
	C1005X7R563□ DTS	1V, 1kHz	56	nF	±10%	0.50	±0.05	±0.05	5.0%		(I)
C1005X7R683□ DTS	1V, 1kHz	68	nF	±10%	0.50	±0.05	±0.05	5.0%	(I)		
C1005X7R823□ DTS	1V, 1kHz	82	nF	±10%	0.50	±0.05	±0.05	5.0%	(I)		
C1005X7R104□ DTS	1V, 1kHz	100	nF	±10%	0.50	±0.05	±0.05	5.0%	(I)		
C1005X7R224□ DTS	1V, 1kHz	220	nF	±10%	0.50	±0.05	±0.05	10.0%	(II)		
6.3V	C1005X7R474□ CTS	1V, 1kHz	470	nF	±10%, ±20%	0.50	±0.05	±0.05	10.0%	Paper, 10kpcs	(II)
	C1005X7R105□ CTS	1V, 1kHz	1.0	uF	±10%, ±20%	0.50	±0.05	±0.05	12.5%		(II)*

● C1608X7R Series (EIA0603)

RV	DARFON P/N	Measuring Condition	Capacitance		Available Tolerance	Thick. (mm)	Tolerance(mm)		DF (max.)	Standard Packing	Test Spec.
			Value	Unit			L/W	Thick.			
50V	C1608X7R101□ GTS	1V, 1kHz	100	pF	±10%	0.80	±0.10	±0.10	2.5%	Paper, 4kpcs	(I)
	C1608X7R121□ GTS	1V, 1kHz	120	pF	±10%	0.80	±0.10	±0.10	2.5%		(I)
	C1608X7R151□ GTS	1V, 1kHz	150	pF	±10%	0.80	±0.10	±0.10	2.5%		(I)
	C1608X7R181□ GTS	1V, 1kHz	180	pF	±10%	0.80	±0.10	±0.10	2.5%		(I)
	C1608X7R221□ GTS	1V, 1kHz	220	pF	±10%	0.80	±0.10	±0.10	2.5%		(I)
	C1608X7R271□ GTS	1V, 1kHz	270	pF	±10%	0.80	±0.10	±0.10	2.5%		(I)
	C1608X7R331□ GTS	1V, 1kHz	330	pF	±10%	0.80	±0.10	±0.10	2.5%		(I)
	C1608X7R391□ GTS	1V, 1kHz	390	pF	±10%	0.80	±0.10	±0.10	2.5%		(I)
	C1608X7R471□ GTS	1V, 1kHz	470	pF	±10%	0.80	±0.10	±0.10	2.5%		(I)
	C1608X7R561□ GTS	1V, 1kHz	560	pF	±10%	0.80	±0.10	±0.10	2.5%		(I)
	C1608X7R681□ GTS	1V, 1kHz	680	pF	±10%	0.80	±0.10	±0.10	2.5%		(I)
	C1608X7R821□ GTS	1V, 1kHz	820	pF	±10%	0.80	±0.10	±0.10	2.5%		(I)
	C1608X7R102□ GTS	1V, 1kHz	1.0	nF	±10%	0.80	±0.10	±0.10	2.5%		(I)
	C1608X7R122□ GTS	1V, 1kHz	1.2	nF	±10%	0.80	±0.10	±0.10	2.5%		(I)
	C1608X7R152□ GTS	1V, 1kHz	1.5	nF	±10%	0.80	±0.10	±0.10	2.5%		(I)
	C1608X7R182□ GTS	1V, 1kHz	1.8	nF	±10%	0.80	±0.10	±0.10	2.5%		(I)
	C1608X7R222□ GTS	1V, 1kHz	2.2	nF	±10%	0.80	±0.10	±0.10	2.5%		(I)
	C1608X7R272□ GTS	1V, 1kHz	2.7	nF	±10%	0.80	±0.10	±0.10	2.5%		(I)
	C1608X7R332□ GTS	1V, 1kHz	3.3	nF	±10%	0.80	±0.10	±0.10	2.5%		(I)
	C1608X7R392□ GTS	1V, 1kHz	3.9	nF	±10%	0.80	±0.10	±0.10	2.5%		(I)
	C1608X7R472□ GTS	1V, 1kHz	4.7	nF	±10%	0.80	±0.10	±0.10	2.5%		(I)
	C1608X7R562□ GTS	1V, 1kHz	5.6	nF	±10%	0.80	±0.10	±0.10	2.5%		(I)
	C1608X7R682□ GTS	1V, 1kHz	6.8	nF	±10%	0.80	±0.10	±0.10	2.5%		(I)
	C1608X7R822□ GTS	1V, 1kHz	8.2	nF	±10%	0.80	±0.10	±0.10	2.5%		(I)
	C1608X7R103□ GTS	1V, 1kHz	10	nF	±10%	0.80	±0.10	±0.10	2.5%		(I)
	C1608X7R123□ GTS	1V, 1kHz	12	nF	±10%	0.80	±0.10	±0.10	2.5%		(I)
	C1608X7R153□ GTS	1V, 1kHz	15	nF	±10%	0.80	±0.10	±0.10	2.5%		(I)
	C1608X7R183□ GTS	1V, 1kHz	18	nF	±10%	0.80	±0.10	±0.10	2.5%		(I)
	C1608X7R223□ GTS	1V, 1kHz	22	nF	±10%	0.80	±0.10	±0.10	2.5%		(I)
	C1608X7R273□ GTS	1V, 1kHz	27	nF	±10%	0.80	±0.10	±0.10	2.5%		(I)
	C1608X7R333□ GTS	1V, 1kHz	33	nF	±10%	0.80	±0.15	±0.15	2.5%		(I)

RV	DARFON P/N	Measuring Condition	Capacitance		Available Tolerance	Thick. (mm)	Tolerance(mm)		DF (max.)	Standard Packing	Test Spec.
			Value	Unit			L/W	Thick.			
50V	C1608X7R393□GTS	1V, 1kHz	39	nF	±10%	0.80	±0.15	±0.15	2.5%	Paper, 4kpcs	(I)
	C1608X7R473□GTS	1V, 1kHz	47	nF	±10%	0.80	±0.15	±0.15	3.0%		(I)
	C1608X7R563□GTS	1V, 1kHz	56	nF	±10%	0.80	±0.15	±0.15	3.0%		(I)
	C1608X7R683□GTS	1V, 1kHz	68	nF	±10%	0.80	±0.15	±0.15	3.0%		(I)
	C1608X7R823□GTS	1V, 1kHz	82	nF	±10%	0.80	±0.15	±0.15	3.0%		(I)
	C1608X7R104□GTS	1V, 1kHz	100	nF	±10%	0.80	±0.15	±0.15	3.0%		(I)
	C1608X7R474□GTS	1V, 1kHz	470	nF	±10%	0.80	±0.15	±0.15	10.0%		(II)
C1608X7R105□GTS	1V, 1kHz	1.0	uF	±10%	0.80	±0.20	±0.20	10.0%	(II)		
25V	C1608X7R101□FTS	1V, 1kHz	100	pF	±10%	0.80	±0.10	±0.10	3.5%	Paper, 4kpcs	(I)
	C1608X7R121□FTS	1V, 1kHz	120	pF	±10%	0.80	±0.10	±0.10	3.5%		(I)
	C1608X7R151□FTS	1V, 1kHz	150	pF	±10%	0.80	±0.10	±0.10	3.5%		(I)
	C1608X7R181□FTS	1V, 1kHz	180	pF	±10%	0.80	±0.10	±0.10	3.5%		(I)
	C1608X7R221□FTS	1V, 1kHz	220	pF	±10%	0.80	±0.10	±0.10	3.5%		(I)
	C1608X7R271□FTS	1V, 1kHz	270	pF	±10%	0.80	±0.10	±0.10	3.5%		(I)
	C1608X7R331□FTS	1V, 1kHz	330	pF	±10%	0.80	±0.10	±0.10	3.5%		(I)
	C1608X7R391□FTS	1V, 1kHz	390	pF	±10%	0.80	±0.10	±0.10	3.5%		(I)
	C1608X7R471□FTS	1V, 1kHz	470	pF	±10%	0.80	±0.10	±0.10	3.5%		(I)
	C1608X7R561□FTS	1V, 1kHz	560	pF	±10%	0.80	±0.10	±0.10	3.5%		(I)
	C1608X7R681□FTS	1V, 1kHz	680	pF	±10%	0.80	±0.10	±0.10	3.5%		(I)
	C1608X7R821□FTS	1V, 1kHz	820	pF	±10%	0.80	±0.10	±0.10	3.5%		(I)
	C1608X7R102□FTS	1V, 1kHz	1.0	nF	±10%	0.80	±0.10	±0.10	3.5%		(I)
	C1608X7R122□FTS	1V, 1kHz	1.2	nF	±10%	0.80	±0.10	±0.10	3.5%		(I)
	C1608X7R152□FTS	1V, 1kHz	1.5	nF	±10%	0.80	±0.10	±0.10	3.5%		(I)
	C1608X7R182□FTS	1V, 1kHz	1.8	nF	±10%	0.80	±0.10	±0.10	3.5%		(I)
	C1608X7R222□FTS	1V, 1kHz	2.2	nF	±10%	0.80	±0.10	±0.10	3.5%		(I)
	C1608X7R272□FTS	1V, 1kHz	2.7	nF	±10%	0.80	±0.10	±0.10	3.5%		(I)
	C1608X7R332□FTS	1V, 1kHz	3.3	nF	±10%	0.80	±0.10	±0.10	3.5%		(I)
	C1608X7R392□FTS	1V, 1kHz	3.9	nF	±10%	0.80	±0.10	±0.10	3.5%		(I)
	C1608X7R472□FTS	1V, 1kHz	4.7	nF	±10%	0.80	±0.10	±0.10	3.5%		(I)
	C1608X7R562□FTS	1V, 1kHz	5.6	nF	±10%	0.80	±0.10	±0.10	3.5%		(I)
	C1608X7R682□FTS	1V, 1kHz	6.8	nF	±10%	0.80	±0.10	±0.10	3.5%		(I)
	C1608X7R822□FTS	1V, 1kHz	8.2	nF	±10%	0.80	±0.10	±0.10	3.5%		(I)
	C1608X7R103□FTS	1V, 1kHz	10	nF	±10%	0.80	±0.10	±0.10	3.5%		(I)
	C1608X7R123□FTS	1V, 1kHz	12	nF	±10%	0.80	±0.10	±0.10	3.5%		(I)
	C1608X7R153□FTS	1V, 1kHz	15	nF	±10%	0.80	±0.10	±0.10	3.5%		(I)
	C1608X7R183□FTS	1V, 1kHz	18	nF	±10%	0.80	±0.10	±0.10	3.5%		(I)
	C1608X7R223□FTS	1V, 1kHz	22	nF	±10%	0.80	±0.10	±0.10	3.5%		(I)
	C1608X7R273□FTS	1V, 1kHz	27	nF	±10%	0.80	±0.10	±0.10	3.5%		(I)
	C1608X7R333□FTS	1V, 1kHz	33	nF	±10%	0.80	±0.10	±0.10	3.5%		(I)
	C1608X7R393□FTS	1V, 1kHz	39	nF	±10%	0.80	±0.10	±0.10	3.5%		(I)
	C1608X7R473□FTS	1V, 1kHz	47	nF	±10%	0.80	±0.10	±0.10	3.5%		(I)
C1608X7R563□FTS	1V, 1kHz	56	nF	±10%	0.80	±0.10	±0.10	3.5%	(I)		
C1608X7R683□FTS	1V, 1kHz	68	nF	±10%	0.80	±0.10	±0.10	3.5%	(I)		
C1608X7R823□FTS	1V, 1kHz	82	nF	±10%	0.80	±0.10	±0.10	3.5%	(I)		
C1608X7R104□FTS	1V, 1kHz	100	nF	±10%	0.80	±0.10	±0.10	3.5%	(I)		
C1608X7R154□FTS	1V, 1kHz	150	nF	±10%	0.80	±0.15	±0.15	10.0%	(I)		
C1608X7R224□FTS	1V, 1kHz	220	nF	±10%	0.80	±0.15	±0.15	3.5%	(I)		
C1608X7R334□FTS	1V, 1kHz	330	nF	±10%	0.80	±0.15	±0.15	7.0%	(I)		
C1608X7R474□FTS	1V, 1kHz	470	nF	±10%	0.80	±0.15	±0.15	10.0%	(I)		
C1608X7R105□FTS	1V, 1kHz	1.0	uF	±10%	0.80	±0.15	±0.15	10.0%	(II)		
16V	C1608X7R101□ETS	1V, 1kHz	100	pF	±10%	0.80	±0.10	±0.10	5.0%	Paper, 4kpcs	(I)
	C1608X7R121□ETS	1V, 1kHz	120	pF	±10%	0.80	±0.10	±0.10	5.0%		(I)
	C1608X7R151□ETS	1V, 1kHz	150	pF	±10%	0.80	±0.10	±0.10	5.0%		(I)
	C1608X7R181□ETS	1V, 1kHz	180	pF	±10%	0.80	±0.10	±0.10	5.0%		(I)
	C1608X7R221□ETS	1V, 1kHz	220	pF	±10%	0.80	±0.10	±0.10	5.0%		(I)
	C1608X7R271□ETS	1V, 1kHz	270	pF	±10%	0.80	±0.10	±0.10	5.0%		(I)
	C1608X7R331□ETS	1V, 1kHz	330	pF	±10%	0.80	±0.10	±0.10	5.0%		(I)
	C1608X7R391□ETS	1V, 1kHz	390	pF	±10%	0.80	±0.10	±0.10	5.0%		(I)
	C1608X7R471□ETS	1V, 1kHz	470	pF	±10%	0.80	±0.10	±0.10	5.0%		(I)
	C1608X7R561□ETS	1V, 1kHz	560	pF	±10%	0.80	±0.10	±0.10	5.0%		(I)
	C1608X7R681□ETS	1V, 1kHz	680	pF	±10%	0.80	±0.10	±0.10	5.0%		(I)
	C1608X7R821□ETS	1V, 1kHz	820	pF	±10%	0.80	±0.10	±0.10	5.0%		(I)

□ Tolerance Code: J=±5%, K=±10%, M=±20%; Special tolerance on the request.

(II)* High temperature load life test are applicable in rated voltage *100%

RV	DARFON P/N	Measuring Condition	Capacitance		Available Tolerance	Thick. (mm)	Tolerance(mm)		DF (max.)	Standard Packing	Test Spec.
			Value	Unit			L/W	Thick.			
16V	C1608X7R102□ ETS	1V, 1kHz	1.0	nF	±10%	0.80	±0.10	±0.10	5.0%	Paper, 4 Kpcs	(I)
	C1608X7R122□ ETS	1V, 1kHz	1.2	nF	±10%	0.80	±0.10	±0.10	5.0%		(I)
	C1608X7R152□ ETS	1V, 1kHz	1.5	nF	±10%	0.80	±0.10	±0.10	5.0%		(I)
	C1608X7R182□ ETS	1V, 1kHz	1.8	nF	±10%	0.80	±0.10	±0.10	5.0%		(I)
	C1608X7R222□ ETS	1V, 1kHz	2.2	nF	±10%	0.80	±0.10	±0.10	5.0%		(I)
	C1608X7R272□ ETS	1V, 1kHz	2.7	nF	±10%	0.80	±0.10	±0.10	5.0%		(I)
	C1608X7R332□ ETS	1V, 1kHz	3.3	nF	±10%	0.80	±0.10	±0.10	5.0%		(I)
	C1608X7R392□ ETS	1V, 1kHz	3.9	nF	±10%	0.80	±0.10	±0.10	5.0%		(I)
	C1608X7R472□ ETS	1V, 1kHz	4.7	nF	±10%	0.80	±0.10	±0.10	5.0%		(I)
	C1608X7R562□ ETS	1V, 1kHz	5.6	nF	±10%	0.80	±0.10	±0.10	5.0%		(I)
	C1608X7R682□ ETS	1V, 1kHz	6.8	nF	±10%	0.80	±0.10	±0.10	5.0%		(I)
	C1608X7R822□ ETS	1V, 1kHz	8.2	nF	±10%	0.80	±0.10	±0.10	5.0%		(I)
	C1608X7R103□ ETS	1V, 1kHz	10	nF	±10%	0.80	±0.10	±0.10	5.0%		(I)
	C1608X7R123□ ETS	1V, 1kHz	12	nF	±10%	0.80	±0.10	±0.10	5.0%		(I)
	C1608X7R153□ ETS	1V, 1kHz	15	nF	±10%	0.80	±0.10	±0.10	5.0%		(I)
	C1608X7R183□ ETS	1V, 1kHz	18	nF	±10%	0.80	±0.10	±0.10	5.0%		(I)
	C1608X7R223□ ETS	1V, 1kHz	22	nF	±10%	0.80	±0.10	±0.10	5.0%		(I)
	C1608X7R273□ ETS	1V, 1kHz	27	nF	±10%	0.80	±0.10	±0.10	5.0%		(I)
	C1608X7R333□ ETS	1V, 1kHz	33	nF	±10%	0.80	±0.10	±0.10	5.0%		(I)
	C1608X7R393□ ETS	1V, 1kHz	39	nF	±10%	0.80	±0.10	±0.10	5.0%		(I)
	C1608X7R473□ ETS	1V, 1kHz	47	nF	±10%	0.80	±0.10	±0.10	5.0%		(I)
	C1608X7R563□ ETS	1V, 1kHz	56	nF	±10%	0.80	±0.10	±0.10	5.0%		(I)
	C1608X7R683□ ETS	1V, 1kHz	68	nF	±10%	0.80	±0.10	±0.10	5.0%		(I)
	C1608X7R823□ ETS	1V, 1kHz	82	nF	±10%	0.80	±0.10	±0.10	5.0%		(I)
	C1608X7R104□ ETS	1V, 1kHz	100	nF	±10%	0.80	±0.10	±0.10	5.0%		(I)
	C1608X7R154□ ETS	1V, 1kHz	150	nF	±10%	0.80	±0.10	±0.10	5.0%		(I)
C1608X7R224□ ETS	1V, 1kHz	220	nF	±10%	0.80	±0.15	±0.15	5.0%	(I)		
C1608X7R334□ ETS	1V, 1kHz	330	nF	±10%	0.80	±0.15	±0.15	5.0%	(I)		
C1608X7R474□ ETS	1V, 1kHz	470	nF	±10%	0.80	±0.15	±0.15	5.0%	(I)		
C1608X7R684□ ETS	1V, 1kHz	680	nF	±10%	0.80	±0.15	±0.15	10.0%	(I)		
C1608X7R105□ ETS	1V, 1kHz	1.0	uF	±10%	0.80	±0.15	±0.15	10.0%	(II)		
10V	C1608X7R101□ DTS	1V, 1kHz	100	pF	±10%	0.80	±0.10	±0.10	5.0%	Paper, 4 Kpcs	(I)
	C1608X7R121□ DTS	1V, 1kHz	120	pF	±10%	0.80	±0.10	±0.10	5.0%		(I)
	C1608X7R151□ DTS	1V, 1kHz	150	pF	±10%	0.80	±0.10	±0.10	5.0%		(I)
	C1608X7R181□ DTS	1V, 1kHz	180	pF	±10%	0.80	±0.10	±0.10	5.0%		(I)
	C1608X7R221□ DTS	1V, 1kHz	220	pF	±10%	0.80	±0.10	±0.10	5.0%		(I)
	C1608X7R271□ DTS	1V, 1kHz	270	pF	±10%	0.80	±0.10	±0.10	5.0%		(I)
	C1608X7R331□ DTS	1V, 1kHz	330	pF	±10%	0.80	±0.10	±0.10	5.0%		(I)
	C1608X7R391□ DTS	1V, 1kHz	390	pF	±10%	0.80	±0.10	±0.10	5.0%		(I)
	C1608X7R471□ DTS	1V, 1kHz	470	pF	±10%	0.80	±0.10	±0.10	5.0%		(I)
	C1608X7R561□ DTS	1V, 1kHz	560	pF	±10%	0.80	±0.10	±0.10	5.0%		(I)
	C1608X7R681□ DTS	1V, 1kHz	680	pF	±10%	0.80	±0.10	±0.10	5.0%		(I)
	C1608X7R821□ DTS	1V, 1kHz	820	pF	±10%	0.80	±0.10	±0.10	5.0%		(I)
	C1608X7R102□ DTS	1V, 1kHz	1.0	nF	±10%	0.80	±0.10	±0.10	5.0%		(I)
	C1608X7R122□ DTS	1V, 1kHz	1.2	nF	±10%	0.80	±0.10	±0.10	5.0%		(I)
	C1608X7R152□ DTS	1V, 1kHz	1.5	nF	±10%	0.80	±0.10	±0.10	5.0%		(I)
	C1608X7R182□ DTS	1V, 1kHz	1.8	nF	±10%	0.80	±0.10	±0.10	5.0%		(I)
	C1608X7R222□ DTS	1V, 1kHz	2.2	nF	±10%	0.80	±0.10	±0.10	5.0%		(I)
	C1608X7R272□ DTS	1V, 1kHz	2.7	nF	±10%	0.80	±0.10	±0.10	5.0%		(I)
	C1608X7R332□ DTS	1V, 1kHz	3.3	nF	±10%	0.80	±0.10	±0.10	5.0%		(I)
	C1608X7R392□ DTS	1V, 1kHz	3.9	nF	±10%	0.80	±0.10	±0.10	5.0%		(I)
	C1608X7R472□ DTS	1V, 1kHz	4.7	nF	±10%	0.80	±0.10	±0.10	5.0%		(I)
	C1608X7R562□ DTS	1V, 1kHz	5.6	nF	±10%	0.80	±0.10	±0.10	5.0%		(I)
	C1608X7R682□ DTS	1V, 1kHz	6.8	nF	±10%	0.80	±0.10	±0.10	5.0%		(I)
	C1608X7R822□ DTS	1V, 1kHz	8.2	nF	±10%	0.80	±0.10	±0.10	5.0%		(I)
	C1608X7R103□ DTS	1V, 1kHz	10	nF	±10%	0.80	±0.10	±0.10	5.0%		(I)
	C1608X7R123□ DTS	1V, 1kHz	12	nF	±10%	0.80	±0.10	±0.10	5.0%		(I)
C1608X7R153□ DTS	1V, 1kHz	15	nF	±10%	0.80	±0.10	±0.10	5.0%	(I)		
C1608X7R183□ DTS	1V, 1kHz	18	nF	±10%	0.80	±0.10	±0.10	5.0%	(I)		
C1608X7R223□ DTS	1V, 1kHz	22	nF	±10%	0.80	±0.10	±0.10	5.0%	(I)		
C1608X7R273□ DTS	1V, 1kHz	27	nF	±10%	0.80	±0.10	±0.10	5.0%	(I)		
C1608X7R333□ DTS	1V, 1kHz	33	nF	±10%	0.80	±0.10	±0.10	5.0%	(I)		
C1608X7R393□ DTS	1V, 1kHz	39	nF	±10%	0.80	±0.10	±0.10	5.0%	(I)		

RV	DARFON P/N	Measuring Condition	Capacitance		Available Tolerance	Thick. (mm)	Tolerance(mm)		DF (max.)	Standard Packing	Test Spec.
			Value	Unit			L/W	Thick.			
10V	C1608X7R473□ DTS	1V, 1kHz	47	nF	±10%	0.80	±0.10	±0.10	5.0%	Paper, 4kpcs	(I)
	C1608X7R563□ DTS	1V, 1kHz	56	nF	±10%	0.80	±0.10	±0.10	5.0%		(I)
	C1608X7R683□ DTS	1V, 1kHz	68	nF	±10%	0.80	±0.10	±0.10	5.0%		(I)
	C1608X7R823□ DTS	1V, 1kHz	82	nF	±10%	0.80	±0.10	±0.10	5.0%		(I)
	C1608X7R104□ DTS	1V, 1kHz	100	nF	±10%	0.80	±0.10	±0.10	5.0%		(I)
	C1608X7R224□ DTS	1V, 1kHz	220	nF	±10%	0.80	±0.15	±0.15	5.0%		(I)
	C1608X7R334□ DTS	1V, 1kHz	330	nF	±10%	0.80	±0.15	±0.15	10.0%		(I)
	C1608X7R474□ DTS	1V, 1kHz	470	nF	±10%	0.80	±0.15	±0.15	10.0%		(I)
	C1608X7R684□ DTS	1V, 1kHz	680	nF	±10%	0.80	±0.15	±0.15	10.0%		(I)
	C1608X7R105□ DTS	1V, 1kHz	1.0	uF	±10%	0.80	±0.15	±0.15	10.0%		(II)
C1608X7R225□ DTS	1V, 1kHz	2.2	uF	±10%	0.80	±0.15	±0.15	10.0%	(II)		
6.3V	C1608X7R225□ CTS	1V, 1kHz	2.2	uF	±10%	0.80	±0.15	±0.15	10.0%		(II)

● C2012X7R Series (EIA0805)

RV	DARFON P/N	Measuring Condition	Capacitance		Available Tolerance	Thick. (mm)	Tolerance(mm)		DF (max.)	Standard Packing	Test Spec.
			Value	Unit			L/W	Thick.			
50V	C2012X7R151□ GTSC	1V, 1kHz	150	pF	±10%	0.60	±0.15	±0.15	2.5%	Paper, 4kpcs	(I)
	C2012X7R151□ GTS	1V, 1kHz	150	pF	±10%	0.85	±0.15	±0.15	2.5%		(I)
	C2012X7R181□ GTSC	1V, 1kHz	180	pF	±10%	0.60	±0.15	±0.15	2.5%		(I)
	C2012X7R181□ GTS	1V, 1kHz	180	pF	±10%	0.85	±0.15	±0.15	2.5%		(I)
	C2012X7R221□ GTSC	1V, 1kHz	220	pF	±10%	0.60	±0.15	±0.15	2.5%		(I)
	C2012X7R221□ GTS	1V, 1kHz	220	pF	±10%	0.85	±0.15	±0.15	2.5%		(I)
	C2012X7R271□ GTSC	1V, 1kHz	270	pF	±10%	0.60	±0.15	±0.15	2.5%		(I)
	C2012X7R271□ GTS	1V, 1kHz	270	pF	±10%	0.85	±0.15	±0.15	2.5%		(I)
	C2012X7R331□ GTSC	1V, 1kHz	330	pF	±10%	0.60	±0.15	±0.15	2.5%		(I)
	C2012X7R331□ GTS	1V, 1kHz	330	pF	±10%	0.85	±0.15	±0.15	2.5%		(I)
	C2012X7R391□ GTSC	1V, 1kHz	390	pF	±10%	0.60	±0.15	±0.15	2.5%		(I)
	C2012X7R391□ GTS	1V, 1kHz	390	pF	±10%	0.85	±0.15	±0.15	2.5%		(I)
	C2012X7R471□ GTSC	1V, 1kHz	470	pF	±10%	0.60	±0.15	±0.15	2.5%		(I)
	C2012X7R471□ GTS	1V, 1kHz	470	pF	±10%	0.85	±0.15	±0.15	2.5%		(I)
	C2012X7R561□ GTSC	1V, 1kHz	560	pF	±10%	0.60	±0.15	±0.15	2.5%		(I)
	C2012X7R561□ GTS	1V, 1kHz	560	pF	±10%	0.85	±0.15	±0.15	2.5%		(I)
	C2012X7R681□ GTSC	1V, 1kHz	680	pF	±10%	0.60	±0.15	±0.15	2.5%		(I)
	C2012X7R681□ GTS	1V, 1kHz	680	pF	±10%	0.85	±0.15	±0.15	2.5%		(I)
	C2012X7R821□ GTSC	1V, 1kHz	820	pF	±10%	0.60	±0.15	±0.15	2.5%		(I)
	C2012X7R821□ GTS	1V, 1kHz	820	pF	±10%	0.85	±0.15	±0.15	2.5%		(I)
	C2012X7R102□ GTSC	1V, 1kHz	1.0	nF	±10%	0.60	±0.15	±0.15	2.5%		(I)
	C2012X7R102□ GTS	1V, 1kHz	1.0	nF	±10%	0.85	±0.15	±0.15	2.5%		(I)
	C2012X7R122□ GTSC	1V, 1kHz	1.2	nF	±10%	0.60	±0.15	±0.15	2.5%		(I)
	C2012X7R122□ GTS	1V, 1kHz	1.2	nF	±10%	0.85	±0.15	±0.15	2.5%		(I)
	C2012X7R152□ GTSC	1V, 1kHz	1.5	nF	±10%	0.60	±0.15	±0.15	2.5%		(I)
	C2012X7R152□ GTS	1V, 1kHz	1.5	nF	±10%	0.85	±0.15	±0.15	2.5%		(I)
	C2012X7R182□ GTSC	1V, 1kHz	1.8	nF	±10%	0.60	±0.15	±0.15	2.5%		(I)
	C2012X7R182□ GTS	1V, 1kHz	1.8	nF	±10%	0.85	±0.15	±0.15	2.5%		(I)
	C2012X7R222□ GTSC	1V, 1kHz	2.2	nF	±10%	0.60	±0.15	±0.15	2.5%		(I)
	C2012X7R222□ GTS	1V, 1kHz	2.2	nF	±10%	0.85	±0.15	±0.15	2.5%		(I)
	C2012X7R272□ GTSC	1V, 1kHz	2.7	nF	±10%	0.60	±0.15	±0.15	2.5%		(I)
	C2012X7R272□ GTS	1V, 1kHz	2.7	nF	±10%	0.85	±0.15	±0.15	2.5%		(I)
	C2012X7R332□ GTSC	1V, 1kHz	3.3	nF	±10%	0.60	±0.15	±0.15	2.5%		(I)
	C2012X7R332□ GTS	1V, 1kHz	3.3	nF	±10%	0.85	±0.15	±0.15	2.5%		(I)
	C2012X7R392□ GTSC	1V, 1kHz	3.9	nF	±10%	0.60	±0.15	±0.15	2.5%		(I)
	C2012X7R392□ GTS	1V, 1kHz	3.9	nF	±10%	0.85	±0.15	±0.15	2.5%		(I)
	C2012X7R472□ GTSC	1V, 1kHz	4.7	nF	±10%	0.60	±0.15	±0.15	2.5%		(I)
	C2012X7R472□ GTS	1V, 1kHz	4.7	nF	±10%	0.85	±0.15	±0.15	2.5%		(I)
	C2012X7R562□ GTSC	1V, 1kHz	5.6	nF	±10%	0.60	±0.15	±0.15	2.5%		(I)
	C2012X7R562□ GTS	1V, 1kHz	5.6	nF	±10%	0.85	±0.15	±0.15	2.5%		(I)
C2012X7R682□ GTSC	1V, 1kHz	6.8	nF	±10%	0.60	±0.15	±0.15	2.5%	(I)		
C2012X7R682□ GTS	1V, 1kHz	6.8	nF	±10%	0.85	±0.15	±0.15	2.5%	(I)		
C2012X7R822□ GTSC	1V, 1kHz	8.2	nF	±10%	0.60	±0.15	±0.15	2.5%	(I)		
C2012X7R822□ GTS	1V, 1kHz	8.2	nF	±10%	0.85	±0.15	±0.15	2.5%	(I)		

□ Tolerance Code: J=±5%, K=±10%, M=±20%; Special tolerance on the request.

(II)* High temperature load life test are applicable in rated voltage *100%

RV	DARFON P/N	Measuring Condition	Capacitance		Available Tolerance	Thick. (mm)	Tolerance(mm)		DF (max.)	Standard Packing	Test Spec.
			Value	Unit			L/W	Thick.			
50V	C2012X7R103□GTSC	1V, 1kHz	10	nF	±10%	0.60	±0.15	±0.15	2.5%	Paper, 4kpcs	(I)
	C2012X7R103□GTS	1V, 1kHz	10	nF	±10%	0.85	±0.15	±0.15	2.5%		(I)
	C2012X7R123□GTSC	1V, 1kHz	12	nF	±10%	0.60	±0.15	±0.15	2.5%		(I)
	C2012X7R123□GTS	1V, 1kHz	12	nF	±10%	0.85	±0.15	±0.15	2.5%		(I)
	C2012X7R153□GTSC	1V, 1kHz	15	nF	±10%	0.60	±0.15	±0.15	2.5%		(I)
	C2012X7R153□GTS	1V, 1kHz	15	nF	±10%	0.85	±0.15	±0.15	2.5%		(I)
	C2012X7R183□GTSC	1V, 1kHz	18	nF	±10%	0.60	±0.15	±0.15	2.5%		(I)
	C2012X7R183□GTS	1V, 1kHz	18	nF	±10%	0.85	±0.15	±0.15	2.5%		(I)
	C2012X7R223□GTSC	1V, 1kHz	22	nF	±10%	0.60	±0.15	±0.15	2.5%		(I)
	C2012X7R223□GTS	1V, 1kHz	22	nF	±10%	0.85	±0.15	±0.15	2.5%		(I)
	C2012X7R273□GTSC	1V, 1kHz	27	nF	±10%	0.60	±0.15	±0.15	2.5%		(I)
	C2012X7R273□GTS	1V, 1kHz	27	nF	±10%	0.85	±0.15	±0.15	2.5%		(I)
	C2012X7R333□GTSC	1V, 1kHz	33	nF	±10%	0.60	±0.15	±0.15	2.5%		(I)
	C2012X7R333□GTS	1V, 1kHz	33	nF	±10%	0.85	±0.15	±0.15	2.5%		(I)
	C2012X7R393□GTSC	1V, 1kHz	39	nF	±10%	0.60	±0.15	±0.15	2.5%		(I)
	C2012X7R393□GTS	1V, 1kHz	39	nF	±10%	0.85	±0.15	±0.15	2.5%		(I)
	C2012X7R473□GTS	1V, 1kHz	47	nF	±10%	0.85	±0.15	±0.15	2.5%		(I)
	C2012X7R563□GTS	1V, 1kHz	56	nF	±10%	0.85	±0.15	±0.15	2.5%		(I)
	C2012X7R683□GTS	1V, 1kHz	68	nF	±10%	0.85	±0.15	±0.15	2.5%		(I)
	C2012X7R823□GTS	1V, 1kHz	82	nF	±10%	0.85	±0.15	±0.15	2.5%		(I)
	C2012X7R104□GTS	1V, 1kHz	100	nF	±10%	0.85	±0.15	±0.15	2.5%		(I)
	C2012X7R124□GTS	1V, 1kHz	120	nF	±10%	0.85	±0.15	±0.15	2.5%		(I)
	C2012X7R154□GTS	1V, 1kHz	150	nF	±10%	0.85	±0.15	±0.15	2.5%		(I)
	C2012X7R184□GTS	1V, 1kHz	180	nF	±10%	0.85	±0.15	±0.15	3.0%		(I)
	C2012X7R224□GTS	1V, 1kHz	220	nF	±10%	0.85	±0.15	±0.15	3.0%		(I)
C2012X7R224□GPS	1V, 1kHz	220	nF	±10%	1.25	±0.15	±0.20	3.0%	Embossed, 3kpcs	(I)	
C2012X7R334□GPS	1V, 1kHz	330	nF	±10%	1.25	±0.15	±0.20	3.0%		(I)	
C2012X7R474□GPS	1V, 1kHz	470	nF	±10%	1.25	±0.15	±0.20	3.5%		(I)	
C2012X7R105□GPS	1V, 1kHz	1.0	uF	±10%	1.25	±0.10	±0.10	10.0%		(II)	
C2012X7R225□GPS	1V, 1kHz	2.2	uF	±10%	1.25	±0.20	±0.20	10.0%		(II)	
25V	C2012X7R102□FTSC	1V, 1kHz	1.0	nF	±10%	0.60	±0.15	±0.15	3.5%	Paper, 4kpcs	(I)
	C2012X7R102□FTS	1V, 1kHz	1.0	nF	±10%	0.85	±0.15	±0.15	3.5%		(I)
	C2012X7R122□FTSC	1V, 1kHz	1.2	nF	±10%	0.60	±0.15	±0.15	3.5%		(I)
	C2012X7R122□FTS	1V, 1kHz	1.2	nF	±10%	0.85	±0.15	±0.15	3.5%		(I)
	C2012X7R152□FTSC	1V, 1kHz	1.5	nF	±10%	0.60	±0.15	±0.15	3.5%		(I)
	C2012X7R152□FTS	1V, 1kHz	1.5	nF	±10%	0.85	±0.15	±0.15	3.5%		(I)
	C2012X7R182□FTSC	1V, 1kHz	1.8	nF	±10%	0.60	±0.15	±0.15	3.5%		(I)
	C2012X7R182□FTS	1V, 1kHz	1.8	nF	±10%	0.85	±0.15	±0.15	3.5%		(I)
	C2012X7R222□FTSC	1V, 1kHz	2.2	nF	±10%	0.60	±0.15	±0.15	3.5%		(I)
	C2012X7R222□FTS	1V, 1kHz	2.2	nF	±10%	0.85	±0.15	±0.15	3.5%		(I)
	C2012X7R272□FTSC	1V, 1kHz	2.7	nF	±10%	0.60	±0.15	±0.15	3.5%		(I)
	C2012X7R272□FTS	1V, 1kHz	2.7	nF	±10%	0.85	±0.15	±0.15	3.5%		(I)
	C2012X7R332□FTSC	1V, 1kHz	3.3	nF	±10%	0.60	±0.15	±0.15	3.5%		(I)
	C2012X7R332□FTS	1V, 1kHz	3.3	nF	±10%	0.85	±0.15	±0.15	3.5%		(I)
	C2012X7R392□FTSC	1V, 1kHz	3.9	nF	±10%	0.60	±0.15	±0.15	3.5%		(I)
	C2012X7R392□FTS	1V, 1kHz	3.9	nF	±10%	0.85	±0.15	±0.15	3.5%		(I)
	C2012X7R472□FTSC	1V, 1kHz	4.7	nF	±10%	0.60	±0.15	±0.15	3.5%		(I)
	C2012X7R472□FTS	1V, 1kHz	4.7	nF	±10%	0.85	±0.15	±0.15	3.5%		(I)
	C2012X7R562□FTSC	1V, 1kHz	5.6	nF	±10%	0.60	±0.15	±0.15	3.5%		(I)
	C2012X7R562□FTS	1V, 1kHz	5.6	nF	±10%	0.85	±0.15	±0.15	3.5%		(I)
	C2012X7R682□FTSC	1V, 1kHz	6.8	nF	±10%	0.60	±0.15	±0.15	3.5%		(I)
	C2012X7R682□FTS	1V, 1kHz	6.8	nF	±10%	0.85	±0.15	±0.15	3.5%		(I)
	C2012X7R822□FTSC	1V, 1kHz	8.2	nF	±10%	0.60	±0.15	±0.15	3.5%		(I)
	C2012X7R103□FTSC	1V, 1kHz	10	nF	±10%	0.60	±0.15	±0.15	3.5%		(I)
	C2012X7R103□FTS	1V, 1kHz	10	nF	±10%	0.85	±0.15	±0.15	3.5%		(I)
C2012X7R123□FTSC	1V, 1kHz	12	nF	±10%	0.60	±0.15	±0.15	3.5%	(I)		
C2012X7R123□FTS	1V, 1kHz	12	nF	±10%	0.85	±0.15	±0.15	3.5%	(I)		
C2012X7R153□FTSC	1V, 1kHz	15	nF	±10%	0.60	±0.15	±0.15	3.5%	(I)		
C2012X7R153□FTS	1V, 1kHz	15	nF	±10%	0.85	±0.15	±0.15	3.5%	(I)		

RV	DARFON P/N	Measuring Condition	Capacitance		Available Tolerance	Thick. (mm)	Tolerance(mm)		DF (max.)	Standard Packing	Test Spec.
			Value	Unit			L/W	Thick.			
25V	C2012X7R183□ FTSC	1V, 1kHz	18	nF	±10%	0.60	±0.15	±0.15	3.5%	Paper, 4kpcs	(I)
	C2012X7R183□ FTS	1V, 1kHz	18	nF	±10%	0.85	±0.15	±0.15	3.5%		(I)
	C2012X7R223□ FTSC	1V, 1kHz	22	nF	±10%	0.60	±0.15	±0.15	3.5%		(I)
	C2012X7R223□ FTS	1V, 1kHz	22	nF	±10%	0.85	±0.15	±0.15	3.5%		(I)
	C2012X7R273□ FTSC	1V, 1kHz	27	nF	±10%	0.60	±0.15	±0.15	3.5%		(I)
	C2012X7R273□ FTS	1V, 1kHz	27	nF	±10%	0.85	±0.15	±0.15	3.5%		(I)
	C2012X7R333□ FTSC	1V, 1kHz	33	nF	±10%	0.60	±0.15	±0.15	3.5%		(I)
	C2012X7R333□ FTS	1V, 1kHz	33	nF	±10%	0.85	±0.15	±0.15	3.5%		(I)
	C2012X7R393□ FTSC	1V, 1kHz	39	nF	±10%	0.60	±0.15	±0.15	3.5%		(I)
	C2012X7R393□ FTS	1V, 1kHz	39	nF	±10%	0.85	±0.15	±0.15	3.5%		(I)
	C2012X7R473□ FTSC	1V, 1kHz	47	nF	±10%	0.85	±0.15	±0.15	3.5%		(I)
	C2012X7R563□ FTS	1V, 1kHz	56	nF	±10%	0.85	±0.15	±0.15	3.5%		(I)
	C2012X7R683□ FTS	1V, 1kHz	68	nF	±10%	0.85	±0.15	±0.15	3.5%		(I)
	C2012X7R823□ FTS	1V, 1kHz	82	nF	±10%	0.85	±0.15	±0.15	3.5%		(I)
	C2012X7R104□ FTS	1V, 1kHz	100	nF	±10%	0.85	±0.15	±0.15	3.5%		(I)
	C2012X7R124□ FTS	1V, 1kHz	120	nF	±10%	0.85	±0.15	±0.15	3.5%		(I)
	C2012X7R154□ FTS	1V, 1kHz	150	nF	±10%	0.85	±0.15	±0.15	3.5%		(I)
	C2012X7R184□ FTS	1V, 1kHz	180	nF	±10%	0.85	±0.15	±0.15	3.5%		(I)
	C2012X7R224□ FTS	1V, 1kHz	220	nF	±10%	0.85	±0.15	±0.15	3.5%		(I)
	16V	C2012X7R334□ FPS	1V, 1kHz	330	nF	±10%	1.25	±0.15	±0.20		5.0%
C2012X7R474□ FPS		1V, 1kHz	470	nF	±10%	1.25	±0.15	±0.20	5.0%	(I)	
C2012X7R105□ FPS		1V, 1kHz	1.0	uF	±10%	1.25	±0.15	±0.15	10.0%	(II)	
C2012X7R225□ FPS		1V, 1kHz	2.2	uF	±10%	1.25	±0.15	±0.20	10.0%	(II)	
C2012X7R475□ FPS		1V, 1kHz	4.7	uF	±10%	1.25	±0.15	±0.15	12.5%	(II)*	
10V	C2012X7R224□ ETS	1V, 1kHz	220	nF	±10%	0.85	±0.15	±0.15	3.5%	Paper, 4kpcs	(I)
	C2012X7R334□ EPS	1V, 1kHz	330	nF	±10%	1.25	±0.15	±0.20	5.0%		(I)
	C2012X7R474□ EPS	1V, 1kHz	470	nF	±10%	1.25	±0.15	±0.20	5.0%		(I)
	C2012X7R105□ EPS	1V, 1kHz	1.0	uF	±10%	1.25	±0.15	±0.20	5.0%		(I)
	C2012X7R225□ EPS	1V, 1kHz	2.2	uF	±10%	1.25	±0.15	±0.20	10.0%		(II)
	C2012X7R475□ EPS	1V, 1kHz	4.7	uF	±10%	1.25	±0.15	±0.20	10.0%		(II)*
6.3V	C2012X7R106□ EPS	0.5V, 1kHz	10	uF	±10%	1.25	±0.15	±0.20	10.0%	Embossed, 3kpcs	(II)*
	C2012X7R105□ DPS	1V, 1kHz	1.0	uF	±10%	1.25	±0.15	±0.20	5.0%		(I)
	C2012X7R225□ DPS	1V, 1kHz	2.2	uF	±10%	1.25	±0.15	±0.20	10.0%		(II)
	C2012X7R475□ DPS	1V, 1kHz	4.7	uF	±10%	1.25	±0.15	±0.20	10.0%		(II)
6.3V	C2012X7R106□ DPS	0.5V, 1kHz	10	uF	±10%	1.25	±0.15	±0.20	10.0%	Embossed, 3kpcs	(II)
	C2012X7R106□ CPS	0.5V, 1kHz	10	uF	±10%, ±20%	1.25	±0.15	±0.20	15.0%		(II)

● C3216X7R Series (EIA1206)

RV	DARFON P/N	Measuring Condition	Capacitance		Available Tolerance	Thick. (mm)	Tolerance(mm)		DF (max.)	Standard Packing	Test Spec.	
			Value	Unit			L/W	Thick.				
50V	C3216X7R562□ GTS	1V, 1kHz	5.6	nF	±5%, ±10%	0.85	±0.15	±0.10	3.5%	Paper, 4kpcs	(I)	
	C3216X7R103□ GTS	1V, 1kHz	10	nF	±10%	0.85	±0.15	±0.10	3.5%		(I)	
	C3216X7R123□ GTS	1V, 1kHz	12	nF	±10%	0.85	±0.15	±0.10	3.5%		(I)	
	C3216X7R153□ GTS	1V, 1kHz	15	nF	±10%	0.85	±0.15	±0.10	3.5%		(I)	
	C3216X7R183□ GTS	1V, 1kHz	18	nF	±10%	0.85	±0.15	±0.10	3.5%		(I)	
	C3216X7R223□ GTS	1V, 1kHz	22	nF	±10%	0.85	±0.15	±0.10	3.5%		(I)	
	C3216X7R273□ GTS	1V, 1kHz	27	nF	±10%	0.85	±0.15	±0.10	3.5%		(I)	
	C3216X7R333□ GTS	1V, 1kHz	33	nF	±10%	0.85	±0.15	±0.10	3.5%		(I)	
	C3216X7R393□ GTS	1V, 1kHz	39	nF	±10%	0.85	±0.15	±0.10	3.5%		(I)	
	C3216X7R473□ GTS	1V, 1kHz	47	nF	±10%	0.85	±0.15	±0.10	3.5%		(I)	
	C3216X7R563□ GTS	1V, 1kHz	56	nF	±10%	0.85	±0.15	±0.10	3.5%		(I)	
	C3216X7R683□ GTS	1V, 1kHz	68	nF	±10%	0.85	±0.15	±0.10	3.5%		(I)	
	C3216X7R823□ GTS	1V, 1kHz	82	nF	±10%	0.85	±0.15	±0.10	3.5%		(I)	
	C3216X7R104□ GTS	1V, 1kHz	100	nF	±10%	0.85	±0.15	±0.10	3.5%		(I)	
	C3216X7R224□ GPS	1V, 1kHz	220	nF	±10%	0.95	±0.15	±0.10	3.5%		(I)	
	C3216X7R334□ GPS	1V, 1kHz	330	nF	±10%	1.25	±0.15	±0.15	3.5%		Embossed, 3kpcs	(I)
	C3216X7R474□ GPSP	1V, 1kHz	470	nF	±10%	1.25	±0.15	±0.15	3.5%		(I)	
	C3216X7R474□ GPS	1V, 1kHz	470	nF	±10%	1.60	±0.15	±0.20	3.5%		Embossed, 2kpcs	(I)

□ Tolerance Code: J=±5%, K=±10%, M=±20%; Special tolerance on the request.

(II)* High temperature load life test are applicable in rated voltage *100%

RV	DARFON P/N	Measuring Condition	Capacitance		Available Tolerance	Thick. (mm)	Tolerance(mm)		DF (max.)	Standard Packing	Test Spec.
			Value	Unit			L/W	Thick.			
50V	C3216X7R105□GPSG	1V, 1kHz	1.0	uF	±10%	1.25	±0.15	±0.15	3.5%	Embossed, 3kpcs	(I)
	C3216X7R105□GPS	1V, 1kHz	1.0	uF	±10%	1.60	±0.30	±0.30	3.5%		(I)
	C3216X7R225□GPS	1V, 1kHz	2.2	uF	±10%	1.60	±0.20	±0.20	10.0%	Embossed, 2kpcs	(II)
	C3216X7R475□GPS	1V, 1kHz	4.7	uF	±10%	1.60	±0.30	±0.30	10.0%		(II)
25V	C3216X7R224□FPS	1V, 1kHz	220	nF	±10%	0.95	±0.15	±0.10	3.5%	Embossed, 3kpcs	(I)
	C3216X7R334□FPS	1V, 1kHz	330	nF	±10%	0.95	±0.15	±0.10	3.5%		(I)
	C3216X7R474□FPS	1V, 1kHz	470	nF	±10%	1.25	±0.15	±0.20	3.5%		(I)
	C3216X7R105□FPS	1V, 1kHz	1.0	uF	±10%	1.25	±0.15	±0.20	3.5%		(I)
	C3216X7R225□FPS	1V, 1kHz	2.2	uF	±10%	1.60	±0.30	±0.30	5.0%	Embossed, 2kpcs	(I)
	C3216X7R475□FPS	1V, 1kHz	4.7	uF	±10%	1.60	±0.30	±0.30	10.0%		(I)
	C3216X7R106□FPS	1V, 1kHz	10	uF	±10%	1.60	±0.30	±0.30	10.0%		(II)
16V	C3216X7R474□EPS	1V, 1kHz	470	nF	±10%	1.25	±0.15	±0.20	5.0%	Embossed, 3kpcs	(I)
	C3216X7R105□EPS	1V, 1kHz	1.0	uF	±10%	1.25	±0.15	±0.20	5.0%		(I)
	C3216X7R225□EPS	1V, 1kHz	2.2	uF	±10%	1.60	±0.30	±0.30	10.0%	Embossed, 2kpcs	(I)
	C3216X7R475□EPS	1V, 1kHz	4.7	uF	±10%	1.60	±0.30	±0.30	10.0%		(I)
	C3216X7R106□EPS	1V, 1kHz	10	uF	±10%, ±20%	1.60	±0.30	±0.30	10.0%		(II)*
10V	C3216X7R225□DPS	1V, 1kHz	2.2	uF	±10%	1.60	±0.30	±0.30	10.0%	Embossed, 2kpcs	(I)
	C3216X7R106□DPS	1V, 1kHz	10	uF	±10%, ±20%	1.60	±0.30	±0.30	10.0%		(II)
	C3216X7R226□DPS	0.5V, 120Hz	22	uF	±10%, ±20%	1.60	±0.30	±0.30	10.0%		(II)
6.3V	C3216X7R226□CPS	0.5V, 120Hz	22	uF	±10%	1.60	±0.30	±0.30	10.0%		(II)

● C3225X7R Series (EIA1210)

RV	DARFON P/N	Measuring Condition	Capacitance		Available Tolerance	Thick. (mm)	Tolerance(mm)		DF (max.)	Standard Packing	Test Spec.
			Value	Unit			L/W	Thick.			
50V	C3225X7R475□GPS	1V, 1kHz	4.7	uF	±10%	2.50	±0.3/±0.2	±0.20	10.0%	Embossed, 1kpcs	(II)
	C3225X7R106□GPS	1V, 1kHz	10	uF	±20%	2.50	±0.30	±0.30	10.0%		(II)
25V	C3225X7R475□FPS	1V, 1kHz	4.7	uF	±10%	2.00	±0.3/±0.2	±0.20	10.0%	Embossed, 2kpcs	(I)
	C3225X7R106□FPS	1V, 1kHz	10	uF	±10%	2.00	±0.3/±0.2	±0.30	10.0%		(II)
16V	C3225X7R106□EPS	1V, 1kHz	10	uF	±10%	2.00	±0.3/±0.2	±0.20	10.0%	Embossed, 1kpcs	(I)
	C3225X7R226□EPS	0.5V, 120Hz	22	uF	±10%	2.50	±0.3/±0.2	±0.30	10.0%		(II)
10V	C3225X7R226□DPS	0.5V, 120Hz	22	uF	±10%	2.50	±0.3/±0.2	±0.20	10.0%	Embossed, 1kpcs	(II)
	C3225X7R476□DPS	0.5V, 120Hz	47	uF	±10%	2.50	±0.3/±0.2	±0.20	10.0%		(II)

■ Y5V Series

● C1005Y5V Series (EIA0402)

RV	DARFON P/N	Measuring Condition	Capacitance		Available Tolerance	Thick. (mm)	Tolerance(mm)		DF (max.)	Standard Packing	Test Spec.
			Value	Unit			L/W	Thick.			
50V	C1005Y5V103ZGTS	1V, 1kHz	10	nF	+80%/-20%	0.50	±0.05	±0.05	7.0%	Paper, 10Kpcs	(I)
	C1005Y5V123ZGTS	1V, 1kHz	12	nF	+80%/-20%	0.50	±0.05	±0.05	9.0%		(I)
	C1005Y5V153ZGTS	1V, 1kHz	15	nF	+80%/-20%	0.50	±0.05	±0.05	9.0%		(I)
	C1005Y5V183ZGTS	1V, 1kHz	18	nF	+80%/-20%	0.50	±0.05	±0.05	9.0%		(I)
	C1005Y5V223ZGTS	1V, 1kHz	22	nF	+80%/-20%	0.50	±0.05	±0.05	9.0%		(I)
	C1005Y5V273ZGTS	1V, 1kHz	27	nF	+80%/-20%	0.50	±0.05	±0.05	9.0%		(I)
C1005Y5V333ZGTS	1V, 1kHz	33	nF	+80%/-20%	0.50	±0.05	±0.05	9.0%	(I)		
25V	C1005Y5V103ZFTS	1V, 1kHz	10	nF	+80%/-20%	0.50	±0.05	±0.05	9.0%		(I)
	C1005Y5V123ZFTS	1V, 1kHz	12	nF	+80%/-20%	0.50	±0.05	±0.05	9.0%		(I)
	C1005Y5V153ZFTS	1V, 1kHz	15	nF	+80%/-20%	0.50	±0.05	±0.05	9.0%		(I)
	C1005Y5V183ZFTS	1V, 1kHz	18	nF	+80%/-20%	0.50	±0.05	±0.05	9.0%		(I)
	C1005Y5V223ZFTS	1V, 1kHz	22	nF	+80%/-20%	0.50	±0.05	±0.05	9.0%		(I)
	C1005Y5V273ZFTS	1V, 1kHz	27	nF	+80%/-20%	0.50	±0.05	±0.05	9.0%		(I)
	C1005Y5V333ZFTS	1V, 1kHz	33	nF	+80%/-20%	0.50	±0.05	±0.05	9.0%		(I)
	C1005Y5V393ZFTS	1V, 1kHz	39	nF	+80%/-20%	0.50	±0.05	±0.05	9.0%		(I)
	C1005Y5V473ZFTS	1V, 1kHz	47	nF	+80%/-20%	0.50	±0.05	±0.05	9.0%		(I)
	C1005Y5V104ZFTS	1V, 1kHz	100	nF	+80%/-20%	0.50	±0.05	±0.05	9.0%		(I)
16V	C1005Y5V103ZETS	1V, 1kHz	10	nF	+80%/-20%	0.50	±0.05	±0.05	9.0%		(I)
	C1005Y5V123ZETS	1V, 1kHz	12	nF	+80%/-20%	0.50	±0.05	±0.05	9.0%	(I)	
	C1005Y5V153ZETS	1V, 1kHz	15	nF	+80%/-20%	0.50	±0.05	±0.05	9.0%	(I)	
	C1005Y5V183ZETS	1V, 1kHz	18	nF	+80%/-20%	0.50	±0.05	±0.05	9.0%	(I)	
	C1005Y5V223ZETS	1V, 1kHz	22	nF	+80%/-20%	0.50	±0.05	±0.05	9.0%	(I)	
	C1005Y5V273ZETS	1V, 1kHz	27	nF	+80%/-20%	0.50	±0.05	±0.05	9.0%	(I)	
	C1005Y5V333ZETS	1V, 1kHz	33	nF	+80%/-20%	0.50	±0.05	±0.05	9.0%	(I)	
	C1005Y5V393ZETS	1V, 1kHz	39	nF	+80%/-20%	0.50	±0.05	±0.05	9.0%	(I)	
	C1005Y5V473ZETS	1V, 1kHz	47	nF	+80%/-20%	0.50	±0.05	±0.05	9.0%	(I)	
	C1005Y5V563ZETS	1V, 1kHz	56	nF	+80%/-20%	0.50	±0.05	±0.05	9.0%	(I)	
	C1005Y5V683ZETS	1V, 1kHz	68	nF	+80%/-20%	0.50	±0.05	±0.05	9.0%	(I)	
	C1005Y5V823ZETS	1V, 1kHz	82	nF	+80%/-20%	0.50	±0.05	±0.05	9.0%	(I)	
	C1005Y5V104ZETS	1V, 1kHz	100	nF	+80%/-20%	0.50	±0.05	±0.05	9.0%	(I)	
	C1005Y5V224ZETS	1V, 1kHz	220	nF	+80%/-20%	0.50	±0.05	±0.05	9.0%	(II)	
C1005Y5V474ZETS	1V, 1kHz	470	nF	+80%/-20%	0.50	±0.05	±0.05	12.5%	(II)		
10V	C1005Y5V104ZDTS	1V, 1kHz	100	nF	+80%/-20%	0.50	±0.05	±0.05	12.5%	(I)	
	C1005Y5V224ZDTS	1V, 1kHz	220	nF	+80%/-20%	0.50	±0.05	±0.05	12.5%	(I)	
	C1005Y5V474ZDTS	1V, 1kHz	470	nF	+80%/-20%	0.50	±0.05	±0.05	16.0%	(I)	
	C1005Y5V105ZDTS	1V, 1kHz	1.0	uF	+80%/-20%	0.50	±0.05	±0.05	16.0%	(II)	
6.3V	C1005Y5V104ZCTS	1V, 1kHz	100	nF	+80%/-20%	0.50	±0.05	±0.05	12.5%	(I)	
	C1005Y5V224ZCTS	1V, 1kHz	220	nF	+80%/-20%	0.50	±0.05	±0.05	12.5%	(I)	
	C1005Y5V474ZCTS	1V, 1kHz	470	nF	+80%/-20%	0.50	±0.05	±0.05	16.0%	(I)	
	C1005Y5V105ZCTS	1V, 1kHz	1.0	uF	+80%/-20%	0.50	±0.05	±0.05	16.0%	(I)	

● C1608Y5V Series (EIA0603)

RV	DARFON P/N	Measuring Condition	Capacitance		Available Tolerance	Thick. (mm)	Tolerance(mm)		DF (max.)	Standard Packing	Test Spec.
			Value	Unit			L/W	Thick.			
50V	C1608Y5V103ZGTS	1V, 1kHz	10	nF	+80%/-20%	0.80	±0.10	±0.10	5.0%	Paper, 4kpcs	(I)
	C1608Y5V123ZGTS	1V, 1kHz	12	nF	+80%/-20%	0.80	±0.10	±0.10	5.0%		(I)
	C1608Y5V153ZGTS	1V, 1kHz	15	nF	+80%/-20%	0.80	±0.10	±0.10	5.0%		(I)
	C1608Y5V183ZGTS	1V, 1kHz	18	nF	+80%/-20%	0.80	±0.10	±0.10	5.0%		(I)
	C1608Y5V223ZGTS	1V, 1kHz	22	nF	+80%/-20%	0.80	±0.10	±0.10	5.0%		(I)
	C1608Y5V273ZGTS	1V, 1kHz	27	nF	+80%/-20%	0.80	±0.10	±0.10	5.0%		(I)
	C1608Y5V333ZGTS	1V, 1kHz	33	nF	+80%/-20%	0.80	±0.10	±0.10	5.0%		(I)
	C1608Y5V393ZGTS	1V, 1kHz	39	nF	+80%/-20%	0.80	±0.10	±0.10	5.0%		(I)
	C1608Y5V473ZGTS	1V, 1kHz	47	nF	+80%/-20%	0.80	±0.10	±0.10	5.0%		(I)
	C1608Y5V563ZGTS	1V, 1kHz	56	nF	+80%/-20%	0.80	±0.10	±0.10	5.0%		(I)
	C1608Y5V683ZGTS	1V, 1kHz	68	nF	+80%/-20%	0.80	±0.10	±0.10	5.0%		(I)
	C1608Y5V823ZGTS	1V, 1kHz	82	nF	+80%/-20%	0.80	±0.10	±0.10	5.0%		(I)
	C1608Y5V104ZGTS	1V, 1kHz	100	nF	+80%/-20%	0.80	±0.10	±0.10	7.0%		(I)
	C1608Y5V224ZGTS	1V, 1kHz	220	nF	+80%/-20%	0.80	±0.10	±0.10	9.0%		(I)
	C1608Y5V474ZGTS	1V, 1kHz	470	nF	+80%/-20%	0.80	±0.15	±0.15	9.0%		(I)

(II)* High temperature load life test are applicable in rated voltage *100%

RV	DARFON P/N	Measuring Condition	Capacitance		Available Tolerance	Thick. (mm)	Tolerance(mm)		DF (max.)	Standard Packing	Test Spec.
			Value	Unit			L/W	Thick.			
25V	C1608Y5V103ZFTS	1V, 1kHz	10	nF	+80%/-20%	0.80	±0.10	±0.10	5.0%	Paper, 4kpcs	(I)
	C1608Y5V123ZFTS	1V, 1kHz	12	nF	+80%/-20%	0.80	±0.10	±0.10	5.0%		(I)
	C1608Y5V153ZFTS	1V, 1kHz	15	nF	+80%/-20%	0.80	±0.10	±0.10	5.0%		(I)
	C1608Y5V183ZFTS	1V, 1kHz	18	nF	+80%/-20%	0.80	±0.10	±0.10	5.0%		(I)
	C1608Y5V223ZFTS	1V, 1kHz	22	nF	+80%/-20%	0.80	±0.10	±0.10	5.0%		(I)
	C1608Y5V273ZFTS	1V, 1kHz	27	nF	+80%/-20%	0.80	±0.10	±0.10	5.0%		(I)
	C1608Y5V333ZFTS	1V, 1kHz	33	nF	+80%/-20%	0.80	±0.10	±0.10	5.0%		(I)
	C1608Y5V393ZFTS	1V, 1kHz	39	nF	+80%/-20%	0.80	±0.10	±0.10	5.0%		(I)
	C1608Y5V473ZFTS	1V, 1kHz	47	nF	+80%/-20%	0.80	±0.10	±0.10	5.0%		(I)
	C1608Y5V563ZFTS	1V, 1kHz	56	nF	+80%/-20%	0.80	±0.10	±0.10	5.0%		(I)
	C1608Y5V683ZFTS	1V, 1kHz	68	nF	+80%/-20%	0.80	±0.10	±0.10	5.0%		(I)
	C1608Y5V823ZFTS	1V, 1kHz	82	nF	+80%/-20%	0.80	±0.10	±0.10	5.0%		(I)
	C1608Y5V104ZFTS	1V, 1kHz	100	nF	+80%/-20%	0.80	±0.10	±0.10	7.0%		(I)
	C1608Y5V224ZFTS	1V, 1kHz	220	nF	+80%/-20%	0.80	±0.10	±0.10	9.0%		(I)
C1608Y5V334ZFTS	1V, 1kHz	330	nF	+80%/-20%	0.80	±0.10	±0.10	9.0%	(I)		
C1608Y5V105ZFTS	1V, 1kHz	1.0	uF	+80%/-20%	0.80	±0.15	±0.15	10.0%	(II)		
16V	C1608Y5V103ZETS	1V, 1kHz	10	nF	+80%/-20%	0.80	±0.10	±0.10	7.0%	Paper, 4kpcs	(I)
	C1608Y5V123ZETS	1V, 1kHz	12	nF	+80%/-20%	0.80	±0.10	±0.10	7.0%		(I)
	C1608Y5V153ZETS	1V, 1kHz	15	nF	+80%/-20%	0.80	±0.10	±0.10	7.0%		(I)
	C1608Y5V183ZETS	1V, 1kHz	18	nF	+80%/-20%	0.80	±0.10	±0.10	7.0%		(I)
	C1608Y5V223ZETS	1V, 1kHz	22	nF	+80%/-20%	0.80	±0.10	±0.10	7.0%		(I)
	C1608Y5V273ZETS	1V, 1kHz	27	nF	+80%/-20%	0.80	±0.10	±0.10	7.0%		(I)
	C1608Y5V333ZETS	1V, 1kHz	33	nF	+80%/-20%	0.80	±0.10	±0.10	7.0%		(I)
	C1608Y5V393ZETS	1V, 1kHz	39	nF	+80%/-20%	0.80	±0.10	±0.10	7.0%		(I)
	C1608Y5V473ZETS	1V, 1kHz	47	nF	+80%/-20%	0.80	±0.10	±0.10	7.0%		(I)
	C1608Y5V563ZETS	1V, 1kHz	56	nF	+80%/-20%	0.80	±0.10	±0.10	7.0%		(I)
	C1608Y5V683ZETS	1V, 1kHz	68	nF	+80%/-20%	0.80	±0.10	±0.10	7.0%		(I)
	C1608Y5V823ZETS	1V, 1kHz	82	nF	+80%/-20%	0.80	±0.10	±0.10	7.0%		(I)
	C1608Y5V104ZETS	1V, 1kHz	100	nF	+80%/-20%	0.80	±0.10	±0.10	7.0%		(I)
	C1608Y5V224ZETS	1V, 1kHz	220	nF	+80%/-20%	0.80	±0.10	±0.10	9.0%		(I)
	C1608Y5V334ZETS	1V, 1kHz	330	nF	+80%/-20%	0.80	±0.10	±0.10	12.5%		(I)
	C1608Y5V474ZETS	1V, 1kHz	470	nF	+80%/-20%	0.80	±0.10	±0.10	12.5%		(I)
C1608Y5V684ZETS	1V, 1kHz	680	nF	+80%/-20%	0.80	±0.10	±0.10	12.5%	(I)		
C1608Y5V824ZETS	1V, 1kHz	820	nF	+80%/-20%	0.80	+0.15/-0.10	+0.15/-0.10	12.5%	(I)		
C1608Y5V105ZETS	1V, 1kHz	1.0	uF	+80%/-20%	0.80	+0.15/-0.10	+0.15/-0.10	12.5%	(I)		
C1608Y5V225ZETS	1V, 1kHz	2.2	uF	+80%/-20%	0.80	+0.15/-0.10	+0.15/-0.10	12.5%	(II)		
10V	C1608Y5V104ZDTS	1V, 1kHz	100	nF	+80%/-20%	0.80	±0.10	±0.10	12.5%	Paper, 4kpcs	(I)
	C1608Y5V224ZDTS	1V, 1kHz	220	nF	+80%/-20%	0.80	±0.10	±0.10	12.5%		(II)
	C1608Y5V334ZDTS	1V, 1kHz	330	nF	+80%/-20%	0.80	±0.10	±0.10	12.5%		(II)
	C1608Y5V474ZDTS	1V, 1kHz	470	nF	+80%/-20%	0.80	±0.10	±0.10	12.5%		(II)
	C1608Y5V105ZDTS	1V, 1kHz	1.0	uF	+80%/-20%	0.80	+0.15/-0.10	+0.15/-0.10	12.5%		(II)
	C1608Y5V225ZDTS	1V, 1kHz	2.2	uF	+80%/-20%	0.80	+0.15/-0.10	+0.15/-0.10	12.5%		(II)
6.3V	C1608Y5V104ZCTS	1V, 1kHz	100	nF	+80%/-20%	0.80	±0.10	±0.10	12.5%	Paper, 4kpcs	(I)
	C1608Y5V224ZCTS	1V, 1kHz	220	nF	+80%/-20%	0.80	±0.10	±0.10	12.5%		(I)
	C1608Y5V334ZCTS	1V, 1kHz	330	nF	+80%/-20%	0.80	±0.10	±0.10	12.5%		(I)
	C1608Y5V474ZCTS	1V, 1kHz	470	nF	+80%/-20%	0.80	±0.10	±0.10	12.5%		(I)
	C1608Y5V105ZCTS	1V, 1kHz	1.0	uF	+80%/-20%	0.80	+0.15/-0.10	+0.15/-0.10	12.5%		(I)
	C1608Y5V225ZCTS	1V, 1kHz	2.2	uF	+80%/-20%	0.80	+0.15/-0.10	+0.15/-0.10	12.5%		(I)
C1608Y5V475ZCTS	1V, 1kHz	4.7	uF	+80%/-20%	0.80	+0.15/-0.10	+0.15/-0.10	12.5%	(II)		

● C2012Y5V Series (EIA0805)

RV	DARFON P/N	Measuring Condition	Capacitance		Available Tolerance	Thick. (mm)	Tolerance(mm)		DF (max.)	Standard Packing	Test Spec.
			Value	Unit			L/W	Thick.			
50V	C2012Y5V104ZGTS	1V, 1kHz	100	nF	+80%/-20%	0.60	±0.15/±0.10	±0.10	5.0%	Paper, 4kpcs	(I)
	C2012Y5V224ZGTS	1V, 1kHz	220	nF	+80%/-20%	0.60	±0.15/±0.10	±0.10	5.0%		(I)
	C2012Y5V334ZGTS	1V, 1kHz	330	nF	+80%/-20%	0.80	±0.15/±0.10	±0.10	5.0%		(I)
	C2012Y5V474ZGTS	1V, 1kHz	470	nF	+80%/-20%	0.80	±0.15/±0.10	±0.10	7.0%		(I)
	C2012Y5V105ZGPTS	1V, 1kHz	1.0	uF	+80%/-20%	1.25	±0.20	±0.20	9.0%		Embossed, 3kpcs
25V	C2012Y5V104ZFTS	1V, 1kHz	100	nF	+80%/-20%	0.60	±0.15/±0.10	±0.10	5.0%	Paper, 4kpcs	(I)
	C2012Y5V224ZFTS	1V, 1kHz	220	nF	+80%/-20%	0.60	±0.15/±0.10	±0.10	5.0%		(I)
	C2012Y5V474ZFTS	1V, 1kHz	470	nF	+80%/-20%	0.80	±0.15/±0.10	±0.10	7.0%		(I)
	C2012Y5V105ZFTS	1V, 1kHz	1.0	uF	+80%/-20%	0.85	±0.20	±0.10	9.0%		(II)
	C2012Y5V105ZFPS	1V, 1kHz	1.0	uF	+80%/-20%	1.25	±0.15/±0.10	±0.20	7.0%		Embossed, 3kpcs
C2012Y5V225ZFPS	1V, 1kHz	2.2	uF	+80%/-20%	1.25	±0.20	±0.20	10.0%	(I)		
16V	C2012Y5V104ZETS	1V, 1kHz	100	nF	+80%/-20%	0.60	±0.15/±0.10	±0.10	5.0%	Paper, 4kpcs	(I)
	C2012Y5V224ZETS	1V, 1kHz	220	nF	+80%/-20%	0.60	±0.15/±0.10	±0.10	5.0%		(I)
	C2012Y5V474ZETS	1V, 1kHz	470	nF	+80%/-20%	0.80	±0.15/±0.10	±0.10	7.0%		(I)
	C2012Y5V105ZETS	1V, 1kHz	1.0	uF	+80%/-20%	0.85	±0.20	±0.10	9.0%		(I)
	C2012Y5V225ZETS	1V, 1kHz	2.2	uF	+80%/-20%	0.85	±0.20	±0.10	9.0%		(I)
	C2012Y5V475ZEPS	1V, 1kHz	4.7	uF	+80%/-20%	1.25	±0.15/±0.10	±0.10	12.5%		Embossed, 3kpcs
10V	C2012Y5V475ZDPS	1V, 1kHz	4.7	uF	+80%/-20%	1.25	±0.15/±0.10	±0.10	12.5%	Embossed, 3kpcs	(II)*
	C2012Y5V106ZDPS	1V, 1kHz	10	uF	+80%/-20%	1.25	±0.20	±0.20	12.5%		(II)*

● C3216Y5V Series (EIA1206)

RV	DARFON P/N	Measuring Condition	Capacitance		Available Tolerance	Thick. (mm)	Tolerance(mm)		DF (max.)	Standard Packing	Test Spec.
			Value	Unit			L/W	Thick.			
50V	C3216Y5V105ZGPS	1V, 1kHz	1.0	uF	+80%/-20%	0.95	±0.15/±0.20	±0.15	7.0%	Embossed, 3kpcs	(I)
	C3216Y5V475ZGPS	1V, 1kHz	4.7	uF	+80%/-20%	1.60	±0.30	±0.30	9.0%	Embossed, 2kpcs	(I)
35V	C3216Y5V475ZNPS	1V, 1kHz	4.7	uF	+80%/-20%	1.15	±0.20	±0.15	12.5%	Embossed, 3kpcs	(II)*
25V	C3216Y5V225ZFPS	1V, 1kHz	2.2	uF	+80%/-20%	0.95	±0.15/±0.20	±0.15	9.0%		(I)
	C3216Y5V475ZFPS	1V, 1kHz	4.7	uF	+80%/-20%	1.15	±0.20	±0.15	9.0%	(I)	
	C3216Y5V106ZFPS	1V, 1kHz	10	uF	+80%/-20%	1.60	±0.30	±0.30	12.5%	Embossed, 2kpcs	(II)
16V	C3216Y5V475ZETS	1V, 1kHz	4.7	uF	+80%/-20%	0.85	±0.30/±0.20	±0.10	12.5%	Paper, 4kpcs	(II)
	C3216Y5V475ZEPS	1V, 1kHz	4.7	uF	+80%/-20%	1.15	±0.20	±0.15	12.5%	Embossed, 3kpcs	(I)
	C3216Y5V106ZEPS	1V, 1kHz	10	uF	+80%/-20%	1.15	±0.20	±0.20	12.5%		(I)
	C3216Y5V226ZEPS	0.5V, 120Hz	22	uF	+80%/-20%	1.60	±0.30	±0.30	12.5%	Embossed, 2kpcs	(I)
10V	C3216Y5V475ZDPS	1V, 1kHz	4.7	uF	+80%/-20%	1.15	±0.20	±0.15	12.5%	Embossed, 3kpcs	(I)
	C3216Y5V226ZDPS	0.5V, 120Hz	22	uF	+80%/-20%	1.60	±0.30	±0.30	20.0%	Embossed, 2kpcs	(II)

● C3225Y5V Series (EIA1210)

RV	DARFON P/N	Measuring Condition	Capacitance		Available Tolerance	Thick. (mm)	Tolerance(mm)		DF (max.)	Standard Packing	Test Spec.
			Value	Unit			L/W	Thick.			
35V	C3225Y5V106ZNPS	1V, 1kHz	10	uF	+80%/-20%	1.60	±0.20	±0.20	9.0%	Embossed, 2kpcs	(I)
16V	C3225Y5V226ZEPS	0.5V, 120Hz	22	uF	+80%/-20%	2.00	±0.30/±0.20	±0.30	16.0%		(I)
6.3V	C3225Y5V476ZCWS	0.5V, 120Hz	47	uF	+80%/-20%	2.00	±0.40/±0.30	±0.20	20.0%	Embossed, 1kpcs	(II)

(II)* High temperature load life test are applicable in rated voltage *100%

- Test Spec.
- General Purpose (I)

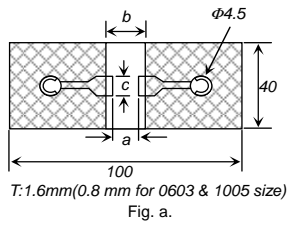
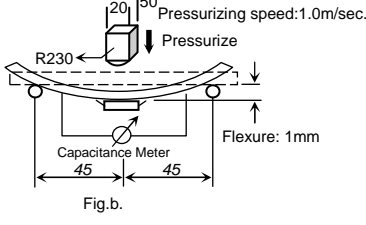
Item	Specification		Test Method																																
	Temp. compensation type	High dielectric constant type																																	
1	Operation Temperature Range	NP0: -55 to 125 °C X7R: -55 to 125 °C X6S: -55 to 105 °C X5R: -55 to 85 °C Y5V: -30 to 85 °C	---																																
2	Rated Voltage	Shown in the table of "Part Number & Characteristic"	The rated voltage is defined as the maximum voltage, which may be applied continuously to the capacitor.																																
3	Appearance	No defects or abnormalities.	Visual inspection																																
4	Dimensions	Within the specified dimension.	Using calipers																																
5	Dielectric Strength	No defects or abnormalities.	No failure shall be observed when 250% of the rated voltage is applied between the terminations for 1 to 5 seconds. The charge and discharge current is less than 50mA.																																
6	Insulation Resistance (I.R.)	To apply rated voltage. I.R. $\geq 10G\Omega$ or $R_C R \geq 500\Omega \cdot F$ (whichever is smaller)	The insulation resistance shall be measured with a DC voltage not exceeding the rated voltage at 25°C and 75%RH max, and within 1 minute of charging.																																
7	Capacitance	Within the specified tolerance * X7R, X6S, X5R and Y5V at 1000 hours	The capacitance / D.F. shall be measured at 25°C at the frequency and voltage shown in the table of "Part Number & Characteristic".																																
8	Q/Dissipation Factor (D.F.)	NP0: If $C \leq 30pF$, $DF \leq 1/(400+20C)$, C in pF If $C > 30pF$, $DF \leq 0.1\%$.	Shown in the table of "Part Number & Characteristic"																																
9	Capacitance Temperature Characteristics	Capacitance change NP0 within $0 \pm 30ppm/^\circ C$ under operating temperature range. X7R/X5R within $\pm 15\%$ X6S within $\pm 22\%$ Y5V: -82 to + 22%	1. Temperature compensation type: The capacitance value at 25°C and 85°C shall be measured and calculated from the formula given below. $T.C. = (C_{85} - C_{25}) / C_{25} \cdot \Delta T \cdot 10^6 (PPM/^\circ C)$ 2. High dielectric constant type: The ranges of capacitance change compared with the 25°C value over the temperature ranges shall be within the specified ranges.																																
10	Termination Strength	No removal of the terminations or marking defect.	Apply a parallel force of 5N to a PCB mounted sample for 10 ± 1 sec. *2N for 0603 (EIA 0201).																																
11	Deflection (Bending Strength)	No cracking or marking defects shall occur at 1mm deflection. Capacitance change: NP0: within $\pm 5\%$ or $\pm 0.5pF$. (whichever is larger) X7R, X6S, X5R: within $\pm 12.5\%$ Y5V: within $\pm 20\%$	Solder the capacitor to the test jig (glass epoxy boards) shown in Fig.a using a SAC305(Sn96.5Ag3.0Cu0.5) solder (then let sit for 24 \pm 2 hours for X7R, X6S, X5R and Y5V). Then apply a force in the direction shown in Fig.b. The soldering shall be done with the reflow method and shall be conducted with care so that the soldering is uniform and free of defects such as heat shock.																																
		(Unit in mm)  <table border="1" data-bbox="774 1366 981 1556"> <thead> <tr> <th>Size</th> <th>a</th> <th>b</th> <th>C</th> </tr> </thead> <tbody> <tr> <td>0603</td> <td>0.3</td> <td>0.9</td> <td>0.3</td> </tr> <tr> <td>1005</td> <td>0.4</td> <td>1.5</td> <td>0.5</td> </tr> <tr> <td>1608</td> <td>1.0</td> <td>3.0</td> <td>1.2</td> </tr> <tr> <td>2012</td> <td>1.2</td> <td>4.0</td> <td>1.65</td> </tr> <tr> <td>3216</td> <td>2.2</td> <td>5.0</td> <td>2.0</td> </tr> <tr> <td>4520</td> <td>3.5</td> <td>7.0</td> <td>2.5</td> </tr> <tr> <td>4532</td> <td>3.5</td> <td>7.0</td> <td>3.7</td> </tr> </tbody> </table> 	Size	a	b	C	0603	0.3	0.9	0.3	1005	0.4	1.5	0.5	1608	1.0	3.0	1.2	2012	1.2	4.0	1.65	3216	2.2	5.0	2.0	4520	3.5	7.0	2.5	4532	3.5	7.0	3.7	
Size	a	b	C																																
0603	0.3	0.9	0.3																																
1005	0.4	1.5	0.5																																
1608	1.0	3.0	1.2																																
2012	1.2	4.0	1.65																																
3216	2.2	5.0	2.0																																
4520	3.5	7.0	2.5																																
4532	3.5	7.0	3.7																																
12	Solderability of Termination	90% of the terminations are to be soldered evenly and continuously.	Immerse the test capacitor into a methanol solution containing rosin for 3 to 5 seconds, preheat it 150 to 180°C for 2 to 3 minutes and immerse it into SAC305(Sn96.5Ag3.0Cu0.5) solder of $245 \pm 5^\circ C$ for 3 ± 1 seconds.																																
13	Resistance to Soldering Heat	Appearance	No marking defects	*Preheat the capacitor at 120 to 150°C for 1 minute.																															
		Cap. Change	NP0 within $\pm 2.5\%$ or 0.25pF (whichever is larger) X7R/X6S/X5R within $\pm 7.5\%$ Y5V within $\pm 20\%$	Immerse the capacitor in a SAC305(Sn96.5Ag3.0Cu0.5) solder solution at $270 \pm 5^\circ C$ for 10 ± 1 seconds. Let sit at room temperature for 24 \pm 2 hours, then measure.																															
		Q/D.F.	If $C \leq 30pF$, $DF \leq 1/(400+20C)$ If $C > 30pF$, $DF \leq 0.1\%$	To satisfy the specified initial spec.	* Preheat 150 to 200°C for size ≥ 3216 .																														
		I.R.	I.R. $\geq 10,000M\Omega$ or $R_C R \geq 500\Omega \cdot F$. (whichever is smaller)	I.R. $\geq 10,000M\Omega$ or $R_C R \geq 500\Omega \cdot F$. (whichever is smaller)	*High dielectric constant type: Initial measurement : perform a heat treatment at $150 \pm 0/-10^\circ C$ for one hour and then let sit for 24 \pm 2 hours at room temperature. Perform the initial measurement.																														

	Item	Specification		Test Method	
		Temp. compensation type	High dielectric constant type		
14	Temperature cycle (Thermal shock)	Appearance	No marking defects		Solder the capacitor to supporting jig (Glass epoxy board) and perform the five cycles according to the four heat treatments listed in the following table. Let sit for 24±2hrs at room temperature, then measure. Step 1: Minimum operating temperature 30±3min Step 2: Room temperature 2-3 min Step 3: Maximum operating temperature 30±3min Step 4: Room temperature 2-3min *High dielectric constant type: Initial measurement: perform a heat treatment at 150±10°C for one hour and then let sit for 24±2 hours at room temp. Perform the initial measurement.
		Cap. Change	NPO within ±2.5% or 0.25pF (whichever is larger)	X7R/X6S/X5R within ±7.5% Y5V within ±20%	
		Q/D.F.	If C ≤ 30pF, DF ≤ 1/(400+20C) If C > 30pF, DF ≤ 0.1%	To satisfy the specified initial spec.	
		I.R.	I.R. ≥ 10GΩ or R _C R ≥ 500Ω-F. (whichever is smaller)	I.R. ≥ 10GΩ or R _C R ≥ 500Ω-F. (whichever is smaller)	
15	Humidity load	Appearance	No marking defects		Apply the rated voltage at 40±2°C and 90 to 95% humidity for 500±12 hours. The charge / discharge current is less than 50mA. [Temperature compensation type] Remove and let sit for 24±2 hours at room temperature, then measure. [High dielectric constant type] *Initial measurement Perform a heat treatment at 150+0/-10°C for one hour and then let sit for 24±2 hours at room temperature. Perform the initial measurement. *Measurement after test Perform a heat treatment and then let sit for 24±2 hours at room temperature, then measure.
		Cap. Change	NPO within ±7.5% or 0.75pF (whichever is larger)	X7R/X6S/X5R within ±12.5% Y5V within ±30%	
		Q/D.F.	If C > 30pF, DF ≤ 0.5% If C ≤ 30pF, DF ≤ 1/(100+10xC/3) C in pF	X7R/X6S/X5R 200% max of initial spec. Y5V 150% max of initial spec.	
		I.R.	I.R. ≥ 500MΩ or R _C R ≥ 25Ω-F. (whichever is smaller)	I.R. ≥ 500MΩ or R _C R ≥ 25Ω-F. (whichever is smaller)	
16	High temperature load life test	Appearance	No marking defects		Apply 200% of the rated voltage for 1000±12 hours at the maximum operating temperature ± 3°C. The charge / discharge current is less than 50mA. [Temperature compensation type] Remove and let sit for 24±2 hours at room temperature, then measure. [High dielectric constant type] *Initial measurement Perform a heat treatment at 150+0/-10°C for one hour and then let sit for 24±2 hours at room temperature. Perform the initial measurement. *Measurement after test Perform a heat treatment and then let sit for 24±2 hours at room temperature, then measure.
		Cap. Change	NPO within ±7.5% or 0.75pF (whichever is larger)	X7R/X6S/X5R within ±12.5% Y5V within ±30%	
		Q/D.F.	If C > 30pF, DF ≤ 0.3% If 10pF < C ≤ 30pF, DF ≤ 1/(275+5xC/2) If C ≤ 10pF, DF ≤ 1/(200+10C), C in pF	X7R/X6S/X5R 200% max of initial spec. Y5V 150% max of initial spec.	
		I.R.	More than 1GΩ or R _C R ≥ 50Ω-F (whichever is less.)	More than 1GΩ or R _C R ≥ 50Ω-F (whichever is less.)	

● General Purpose (II)

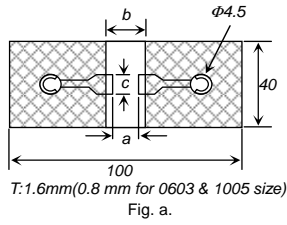
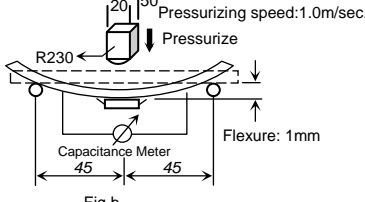
Item	Specification	Test Method																																
1	Operation Temperature Range X7R: -55 to 125 °C X6S: -55 to 105 °C X5R: -55 to 85 °C Y5V: -30 to 85 °C	---																																
2	Rated Voltage Shown in the table of "Part Number & Characteristic"	The rated voltage is defined as the maximum voltage, which may be applied continuously to the capacitor.																																
3	Appearance No defects or abnormalities.	Visual inspection																																
4	Dimensions Within the specified dimension.	Using calipers																																
5	Dielectric Strength No defects or abnormalities.	No failure shall be observed when 250% of the rated voltage is applied between the terminations for 1 to 5 seconds. The charge and discharge current is less than 50mA.																																
6	Insulation Resistance (I.R.) R _{CR} ≥ 50Ω-F	The insulation resistance shall be measured with a DC voltage not exceeding the rated voltage at 25°C and 75%RH max, and within 1 minute of charging, provided the charge/discharge current is less than 50 mA.																																
7	Capacitance Within the specified tolerance * X7R, X6S, X5R and Y5V at 1000 hours	The capacitance / D.F. shall be measured at 25°C at the frequency and voltage shown in the table of "Part Number & Characteristic".																																
8	Q/Dissipation Factor (D.F.) Shown in the table of "Part Number & Characteristic"																																	
9	Capacitance Temperature Characteristics Capacitance change X7R/X5R within ±15% X6S within ±22% Y5V: -82 to + 22%	The ranges of capacitance change compared with the 25°C value over the temperature ranges shall be within the specified ranges.																																
10	Termination Strength No removal of the terminations or marking defect.	Apply a parallel force of 5N to a PCB mounted sample for 10±1sec. *2N for 0603 (EIA 0201).																																
11	Deflection (Bending Strength) No cracking or marking defects shall occur at 1mm deflection. Capacitance change: X7R, X6S, X5R: within ±12.5% Y5V: within ±20% (Unit in mm)  <table border="1" data-bbox="774 1142 981 1332"> <thead> <tr> <th>Size</th> <th>a</th> <th>b</th> <th>C</th> </tr> </thead> <tbody> <tr> <td>0603</td> <td>0.3</td> <td>0.9</td> <td>0.3</td> </tr> <tr> <td>1005</td> <td>0.4</td> <td>1.5</td> <td>0.5</td> </tr> <tr> <td>1608</td> <td>1.0</td> <td>3.0</td> <td>1.2</td> </tr> <tr> <td>2012</td> <td>1.2</td> <td>4.0</td> <td>1.65</td> </tr> <tr> <td>3216</td> <td>2.2</td> <td>5.0</td> <td>2.0</td> </tr> <tr> <td>4520</td> <td>3.5</td> <td>7.0</td> <td>2.5</td> </tr> <tr> <td>4532</td> <td>3.5</td> <td>7.0</td> <td>3.7</td> </tr> </tbody> </table> 	Size	a	b	C	0603	0.3	0.9	0.3	1005	0.4	1.5	0.5	1608	1.0	3.0	1.2	2012	1.2	4.0	1.65	3216	2.2	5.0	2.0	4520	3.5	7.0	2.5	4532	3.5	7.0	3.7	Solder the capacitor to the test jig (glass epoxy boards) shown in Fig.a using a SAC305(Sn96.5Ag3.0Cu0.5) solder (then let sit for 24±2 hours for X7R X5R and Y5V). Then apply a force in the direction shown in Fig.b. The soldering shall be done with the reflow method and shall be conducted with care so that the soldering is uniform and free of defects such as heat shock.
Size	a	b	C																															
0603	0.3	0.9	0.3																															
1005	0.4	1.5	0.5																															
1608	1.0	3.0	1.2																															
2012	1.2	4.0	1.65																															
3216	2.2	5.0	2.0																															
4520	3.5	7.0	2.5																															
4532	3.5	7.0	3.7																															
12	Solderability of Termination 90% of the terminations are to be soldered evenly and continuously.	Immerse the test capacitor into a methanol solution containing rosin for 3 to 5 seconds, preheat it 150 to 180°C for 2 to 3 minutes and immerse it into SAC305(Sn96.5Ag3.0Cu0.5) solder of 245 ± 5°C for 3±1seconds.																																
13	Resistance to Soldering Heat																																	
	Appearance	No marking defects	*Preheat the capacitor at 120 to 150°C for 1 minute.																															
	Cap. Change	X7R/X6S/X5R within ±% Y5V within ±20%	Immerse the capacitor in a SAC305(Sn96.5Ag3.0Cu0.5) solder solution at 270±5°C for 10±1 seconds. Let sit at room temperature for 24±2 hours, then measure.																															
	D.F.	To satisfy the specified initial spec.	* Preheat 150 to 200°C for size ≥ 3216.																															
	I.R.	R _{CR} ≥ 50Ω-F.	* Initial measurement : perform a heat treatment at 150+0/-10°C for one hour and then let sit for 24±2 hours at room temperature. Perform the initial measurement.																															

Item		Specification	Test Method
14	Temperature cycle (Thermal shock)	Appearance	Solder the capacitor to supporting jig (Glass epoxy board) and perform the five cycles according to the four heat treatments listed in the following table. Let sit for 24±2hrs at room temperature, then measure. Step 1: Minimum operating temperature 30±3min Step 2: Room temperature 2-3 min Step 3: Maximum operating temperature 30±3min Step 4: Room temperature 2-3min * Initial measurement: perform a heat treatment at 150±10°C for one hour and then let sit for 24±2 hours at room temp. Perform the initial measurement.
		Cap. Change	
		Q/D.F.	
		I.R.	
15	Humidity load	Appearance	Apply the rated voltage at 40±2°C and 90 to 95% humidity for 500±12 hours. The charge / discharge current is less than 50mA. *Initial measurement Perform a heat treatment at 150+0/-10°C for one hour and then let sit for 24±2 hours at room temperature. Perform the initial measurement. *Measurement after test Perform a heat treatment and then let sit for 24±2 hours at room temperature, then measure.
		Cap. Change	
		Q/D.F.	
		I.R.	
16	High temperature load life test	Appearance	Apply 150% of the rated voltage for 1000±12 hours at the maximum operating temperature ± 3°C. The charge / discharge current is less than 50mA. *Initial measurement Perform a heat treatment at 150+0/-10°C for one hour and then let sit for 24±2 hours at room temperature. Perform the initial measurement. *Measurement after test Perform a heat treatment and then let sit for 24±2 hours at room temperature, then measure. * Some of the parts are applicable in rated voltage *100%. Please refer to "Part Number & Characteristic" with (II)* labeled in "Test Spec."
		Cap. Change	
		D.F.	
		I.R.	

Package

- Tape and reel packaging**

Tape and reel packaging is currently the most promising system for high-speed production. A typical 180mm (7 inch) diameter reel contains 1,500 to 15,000 capacitors, 250mm (10 inch) contains 10,000 capacitors, and 330mm (13 inch) contains 10,000 to 50,000 capacitors. Three standard sizes are available in taped and reeled package either with paper carrier tapes or embossed tapes.

【Paper tape specifications】

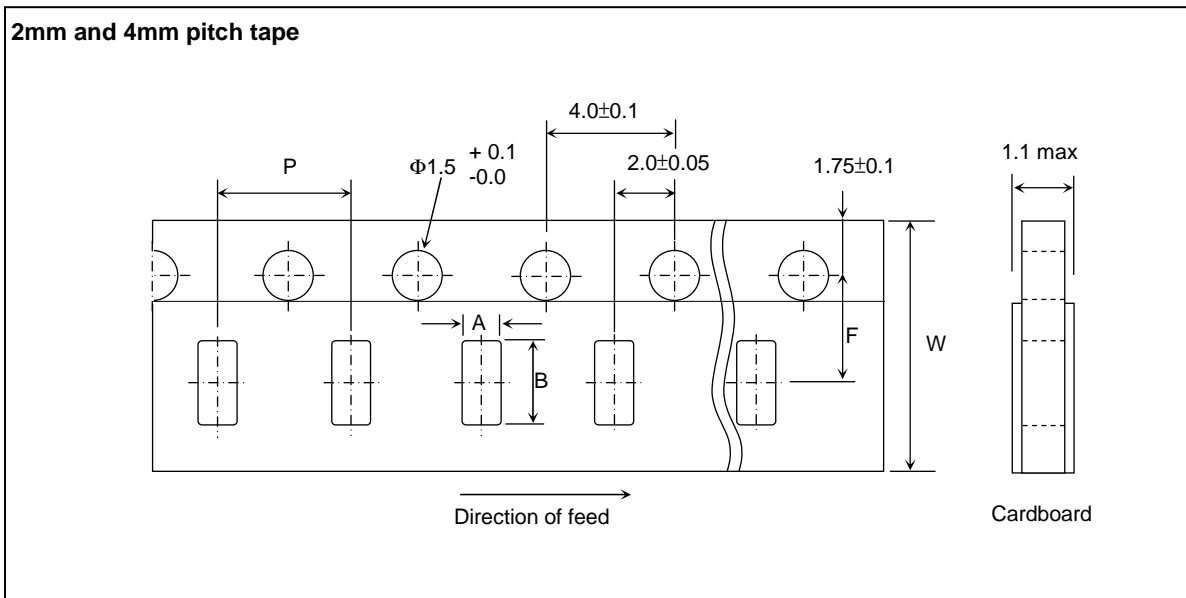

SYMBOL	PRODUCT SIZE CODE												UNIT
	0402(01005)		0603(0201)		1005(0402) (±0.05 mm)		1005(0402) (±0.10 mm)		1005(0402) (±0.15 mm)		1005(0402) (±0.20 mm)		
	SIZE	TOL.	SIZE	TOL.	SIZE	TOL.	SIZE	TOL.	SIZE	TOL.	SIZE	TOL.	
A	0.23	±0.02	0.38	±0.04	0.65	±0.10	0.70	±0.10	0.72	±0.10	0.80	±0.10	mm
B	0.43	±0.02	0.68	±0.04	1.15	±0.10	1.19	±0.10	1.25	±0.10	1.35	±0.10	mm
F	3.5	±0.05	3.5	±0.05	3.5	±0.05	3.5	±0.05	3.5	±0.05	3.5	±0.05	mm
P	2	±0.05	2	±0.10	2	±0.10	2	±0.10	2	±0.10	2	±0.10	mm
W	8	±0.20	8	±0.20	8	±0.20	8	±0.20	8	±0.20	8	±0.20	mm

SYMBOL	PRODUCT SIZE CODE (EIA)								UNIT
	1608 (0603) (±0.15 mm)		1608 (0603) (±0.20 mm)		2012 (0805)		3216 (1206)		
	Size	Tol.	Size	Tol.	Size	Tol.	Size	Tol.	
A	1.0	±0.2	1.1	±0.2	1.5	±0.2	1.9	±0.2	mm
B	1.8	±0.2	1.9	±0.2	2.3	±0.2	3.6	±0.2	mm
F	3.5	±0.05	3.5	±0.05	3.5	±0.05	3.5	±0.05	mm
P	4	±0.1	4	±0.1	4	±0.1	4	±0.1	mm
W	8	±0.2	8	±0.2	8	±0.2	8	±0.2	mm

【 Embossed tape specifications 】

1mm and 4mm and 8mm pitch tape

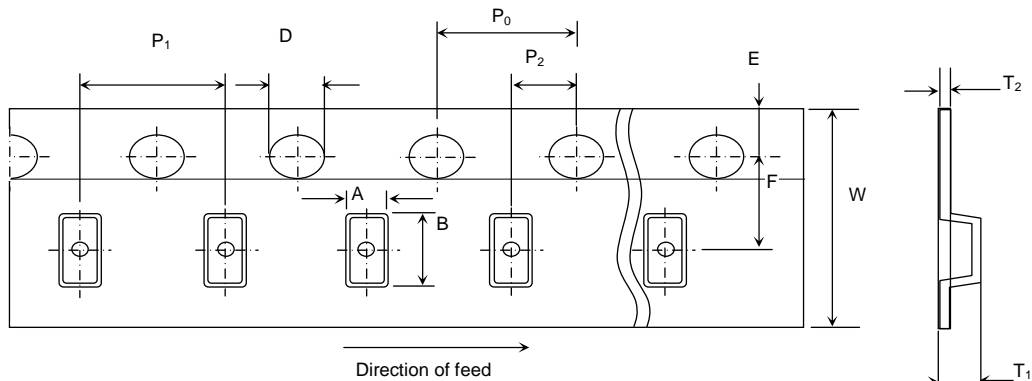

For $W= 8\text{mm}$: $T_1=2.5\text{mm}$ max.

For $W= 12\text{mm}$: $T_1= 4.5\text{mm}$

DIMENSION (mm)	PRODUCT SIZE CODE						
	1mm tape	4 mm tape				8 mm tape	
	0402 (01005)	1608 (0603)	2012 (0805)	3216 (1206)	3225 (1210)	4520 (1808)	4532 (1812)
P_1	1 ± 0.02	4 ± 0.1	4 ± 0.1	4 ± 0.1	4 ± 0.1	8 ± 0.1	8 ± 0.1
P_0	2 ± 0.04	4 ± 0.1	4 ± 0.1	4 ± 0.1	4 ± 0.1	4 ± 0.1	4 ± 0.1
P_2	1 ± 0.02	2 ± 0.05	2 ± 0.05	2 ± 0.05	2 ± 0.05	2 ± 0.05	2 ± 0.05
A	0.23 ± 0.02	1.2 ± 0.2	1.45 ± 0.2	1.9 ± 0.2	2.8 ± 0.2	2.3 ± 0.2	3.6 ± 0.2
B	0.43 ± 0.02	2.0 ± 0.2	2.3 ± 0.2	3.5 ± 0.2	3.6 ± 0.2	4.9 ± 0.2	4.9 ± 0.2
W	4 ± 0.05	8 ± 0.3	8 ± 0.2	8 ± 0.2	8 ± 0.2	12 ± 0.2	12 ± 0.2
E	0.9 ± 0.05	1.75 ± 0.1	1.75 ± 0.1	1.75 ± 0.1	1.75 ± 0.1	1.75 ± 0.1	1.75 ± 0.1
F	1.8 ± 0.02	3.5 ± 0.05	3.5 ± 0.05	3.5 ± 0.05	3.5 ± 0.05	5.5 ± 0.05	5.5 ± 0.05
D	0.8 ± 0.04	1.5 (+0.1/-0.0)	1.5 (+0.1/-0.0)	1.5 (+0.1/-0.0)	1.5 (+0.1/-0.0)	1.5 (+0.1/-0.0)	1.5 (+0.1/-0.0)
T_1	0.5 max	1.4 max.	2.5 max.	2.5 max.	2.5 max.	4.5	4.5
T_2	0.15~0.40	0.25 ± 0.1	0.305 ± 0.1	0.30 ± 0.1	0.30 ± 0.1	0.30 ± 0.1	0.30 ± 0.1

【Reel specifications】

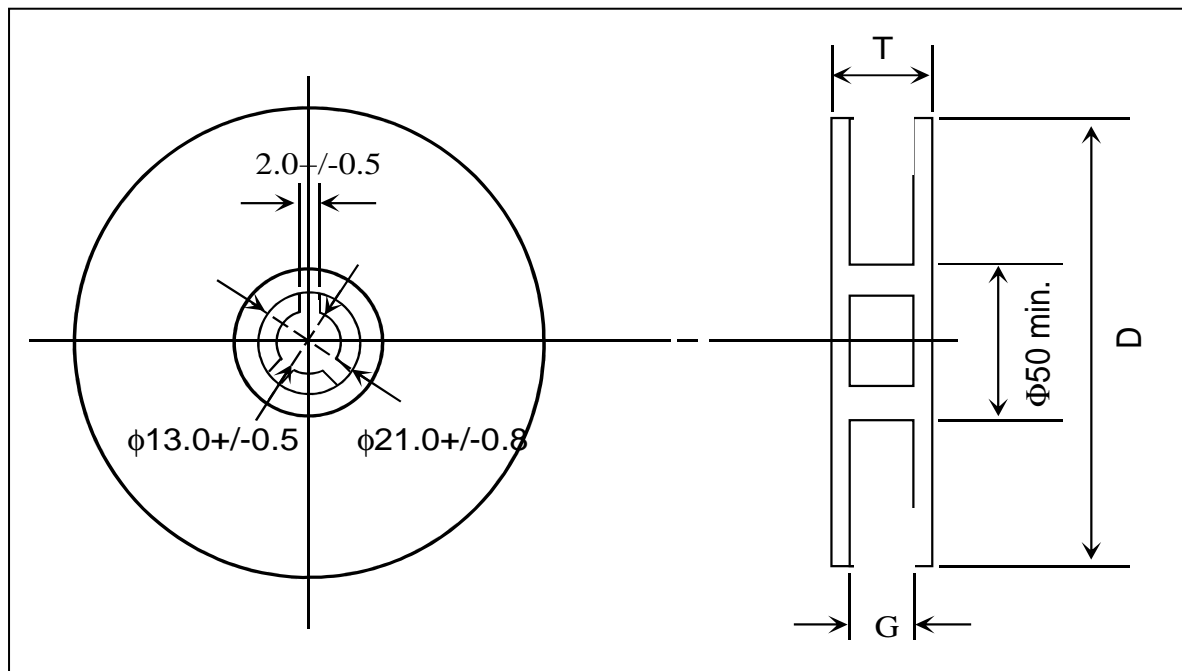

TAPE WIDTH (mm)	G (mm)	T max. (mm)	D (mm)
4	5.0 ± 1.5	8.0	180
8	10.0 ± 1.5	14.5	180
8	10.0 ± 1.5	14.5	250
8	10.0 ± 1.5	14.5	330
12	14.0 ± 1.5	18.5	180

MLCC

【Thickness and Packing Amount】

Thickness			Amount per reel			
			180 mm (7")		330 mm (13")	
Code	Spec.(mm)	Size (EIA)	Paper	Embossed	Paper	Embossed
Z	0.20	0402 (01005)	20K	40K ^{#1}		
A	0.30	0603 (0201)	15K		50K	
		1005 (0402)	15K		50K	
B	0.50	1005 (0402)	10K		50K	
Q	0.45	1005 (0402)	10K		50K	
		1608 (0603)	4K		15K	
C	0.60	2012 (0805)	4K		15K	
		3216 (1206)	4K		15K	
D	0.80	1608 (0603)	4K	4K	15K	
E	0.85	2012 (0805)	4K		15K	
		3216 (1206)	4K		15K	
		3225 (1210)		3K		10K
I	0.95	4532 (1812)		1K		
		2012 (0805)		3K		
F	1.15	3216 (1206)		3K		10K
		4520 (1808)		3K		
H	1.25	2012 (0805)		2K/3K		10K
		3216 (1206)		3K		10K
		3225 (1210)		3K		
		4520 (1808)		2K/3K		
		4532 (1812)		1K		
		3225 (1210)		3K		
L	1.60	3216 (1206)		2K		
		3225 (1210)		2K		
		4520 (1808)		2K		
		4532 (1812)		1K		
N	2.00	3216 (1206)		2K/3K		
		3225 (1210)		2K		
		4520 (1808)		1K		
		4532 (1812)		1K		
P	2.50	3225 (1210)		500pcs/1K		

#1: 4mm width 1mm pitch Embossed Taping

【Packing Rule】

EIA SIZE	Tape	Reel Size	Reels/Box	Boxes/ Carton
01005	Emboss	7"	8	12
01005	Paper	7"	5	12
0201	Paper	7"	5	12
0402	Paper	7"	5	12
0603	Paper/Emboss	7"	5	12
0805	Paper/Emboss	7"	5	12
1206	Paper/Emboss	7"	5	12
1210	Emboss	7"	5	12
1808	Emboss	7"	5	12
1812	Emboss	7"	5	12

Others

【Storage】

1. The chip capacitors shall be packaged in carrier tapes or bulk cases.
2. Keep storage place temperatures from +5°C to +35°C, humidity from 45 to 70% RH.
3. The storage atmosphere must be free of gas containing sulfur and chlorine. Also, avoid exposing the product to saline moisture. If the product is exposed to such atmospheres, the terminations will oxidize and solderability will be affected.
4. The solderability is assured for 12 months from our final inspection date if the above storage condition is followed.

【Circuit Design】

1. Once application and assembly environments have been checked, the capacitor may be used in conformance with the rating and performance, which are provided in both the catalog and the specifications. Exceeding the specifications listed may result in inferior performance. It may also cause a short, open, smoking, or flaming to occur, etc.
2. Please use the capacitors in conformance with the operating temperature provided in both the catalog and the specifications. Be especially cautious not to exceed the maximum temperature. In the situation the maximum temperature set forth in both the catalog and specifications is exceeded, the capacitor's insulation resistance may deteriorate, power may suddenly surge and short-circuit may occur. The loss of capacitance will occur, and may self-heat due to equivalent series resistance when alternating electric current is passed through. As this effect becomes critical in high frequency circuits, please exercise with caution. When using the capacitor in a (self-heating) circuit, please make sure the surface of the capacitor remains under the maximum temperature for usage. Also, please make certain temperature rise remain below 20°C.
3. Please keep voltage under the rated voltage, which is applied to the capacitor. Also, please make certain the peak voltage remains below the rated voltage when AC voltage is super-imposed to the DC voltage. In the situation where AC or pulse voltage is employed, ensure average peak voltage does not exceed the rated voltage. Exceeding the rated voltage provided in both catalog and specifications may lead to defective withstanding voltage or, in worse case situations, may cause the capacitor to burn out.
4. It's is a common phenomenon of high-dielectric products to have a deteriorated amount of static electricity due to the application of DC voltage.

【Handling】

Chip capacitors should be handled with care to avoid contamination or damage. The use of vacuum pick-up or plastic tweezers is recommended for manual placement. Tape and reeled packages are suitable for automatic pick and placement machine.

【Flux】

1. An excessive amount of flux or too rapid temperature rise can cause solvent burst, solder can generate a large quantity of gas. The gas can spread small solder particles to cause solder balling effect or bridging problem.
2. Flux containing too high of a percentage of halide may cause corrosion of termination unless sufficient cleaning is applied.
3. Use rosin-type flux. Highly acidic flux (halide content less than 0.2wt%) is not recommended.
4. The water soluble flux causes deteriorated insulation resistance between outer terminations unless sufficiently cleaned.

【Component Spacing】

For wave soldering components, the spacing must be sufficient far apart to prevent bridging or shadowing. This is not so important for reflow process but enough space for rework should be considered. The suggested spacing for reflow soldering and wave soldering is 0.5mm and 1.0mm, respectively.

【Solder Fillet】

Too much solder amount may increase solder stress and cause crack risk. Insufficient solder amount may reduce adhesive strength and cause parts falling off PCB. When soldering, confirm that the solder is placed over 0.2mm of the surface of the terminations.

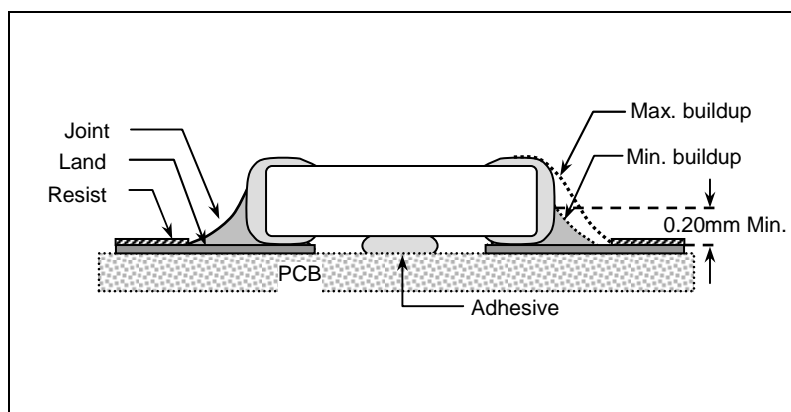

【Recommended Land Pattern Dimensions】

When mounting the capacitor to substrate, it's important to consider that the amount of solder (size of fillet) used has a direct effect upon the capacitor once it's mounted.

1. The greater the amount of solder, the greater the stress to the elements, as this may cause the substrate to break or crack.
2. In the situation where two or more devices are mounted onto a common land, separate the device into exclusive pads by using soldering resist.
3. Land width equal to or less than component. It is permissible to reduce land width to 80% of component width.

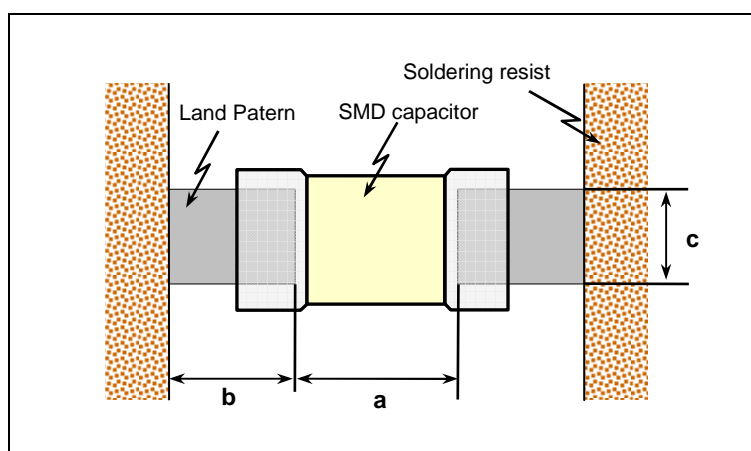

Size mm (EIA)	L x W (mm) (Dimension tolerance)	a (mm)	b (mm)	c (mm)
0402 (01005)	0.4*0.2	0.16 to 0.20	0.12 to 0.18	0.20 to 0.23
0603 (0201)	0.6*0.3	0.15 to 0.35	0.2 to 0.3	0.25 to 0.3
1005 (0402)	1.0*0.5 (within±0.10)	0.3 to 0.5	0.35 to 0.45	0.4 to 0.5
	1.0*0.5 (±0.15 or ±0.20)	0.4 to 0.6	0.4 to 0.5	0.5 to 0.6
1608 (0603)	1.6*0.8 (within±0.10)	0.7 to 1.0	0.6 to 0.8	0.7 to 0.8
	1.6*0.8 (±0.15 or ±0.20)	0.8 to 1.1	0.7 to 0.9	0.8 to 0.9
2012 (0805)	2.0*1.25	1.0 to 1.3	0.7 to 0.9	1.0 to 1.2
3216 (1206)	3.2*1.6	2.1 to 2.5	1.0 to 1.2	1.3 to 1.6
3225 (1210)	3.2*2.5	2.1 to 2.5	1.0 to 1.2	2.0 to 2.5
4520 (1808)	4.5*2.0	3.2 to 3.8	1.2 to 1.4	1.7 to 2.0
4532 (1812)	4.5*3.2	3.2 to 3.8	1.2 to 1.4	2.7 to 3.2

【Resin Mold】

If a large amount of resin is used for molding the chip, cracks may occur due to contraction stress during curing. To avoid such cracks, use a low shrinkage resin. The insulation resistance of the chip will degrade due to moisture absorption. Use a low moisture absorption resin. Check carefully that the resin does not generate a decomposition gas or reaction gas during the curing process or during normal storage. Such gases may crack the chip capacitor or damage the device itself.

【Soldering Profile for SMT Process with SnPb Solder Paste】

Reflow Soldering

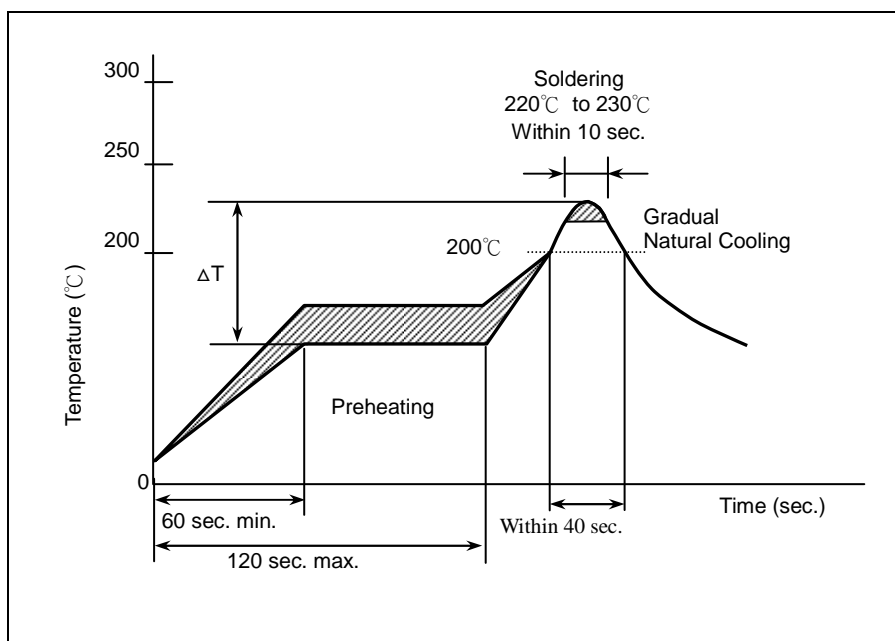

The difference between solder and chip surface should be controlled as following table. The rate of preheat should not exceed 4°C/sec and a target of 2°C/sec is preferred.

Chip Size	3216 and smaller	3225 and above
Preheating	$\Delta T \leq 150^\circ\text{C}$	$\Delta T \leq 130^\circ\text{C}$

Wave Soldering

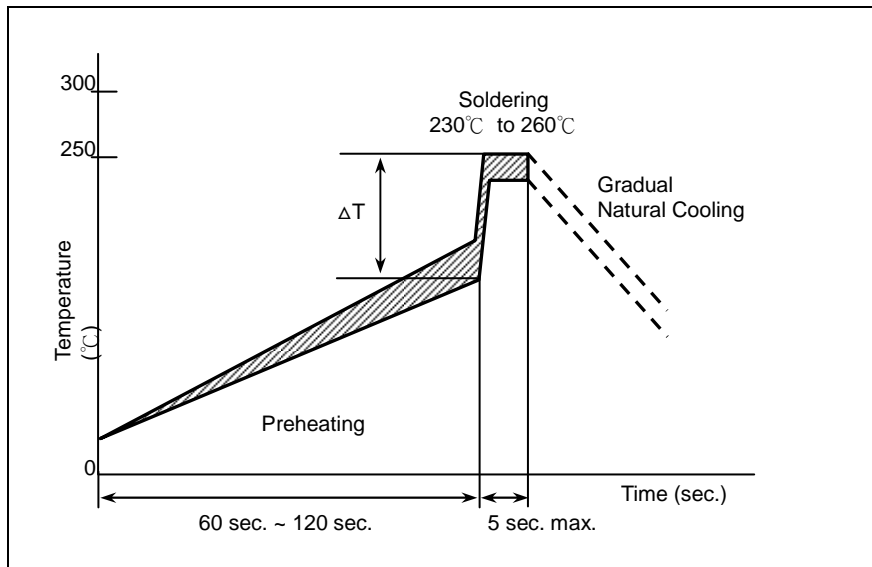

Chip Size	3216 and smaller	3225 and above
Preheating	$\Delta T \leq 150^\circ\text{C}$	-

Soldering Iron

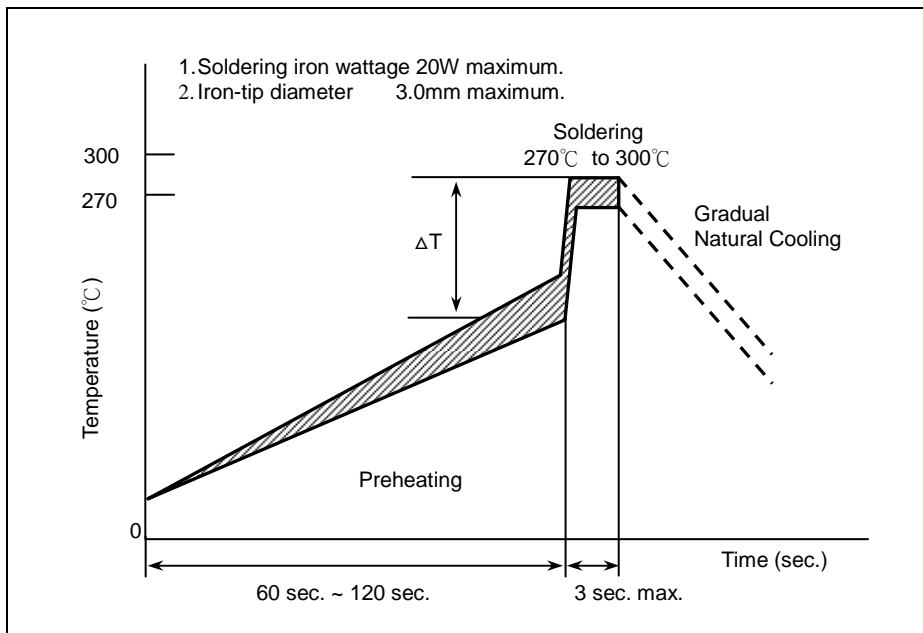

Chip Size	3216 and smaller	3225 and above
Preheating	$\Delta T \leq 190^\circ\text{C}$	$\Delta T \leq 130^\circ\text{C}$

MLCC

[Soldering]

Reflow Soldering for Lead free Termination

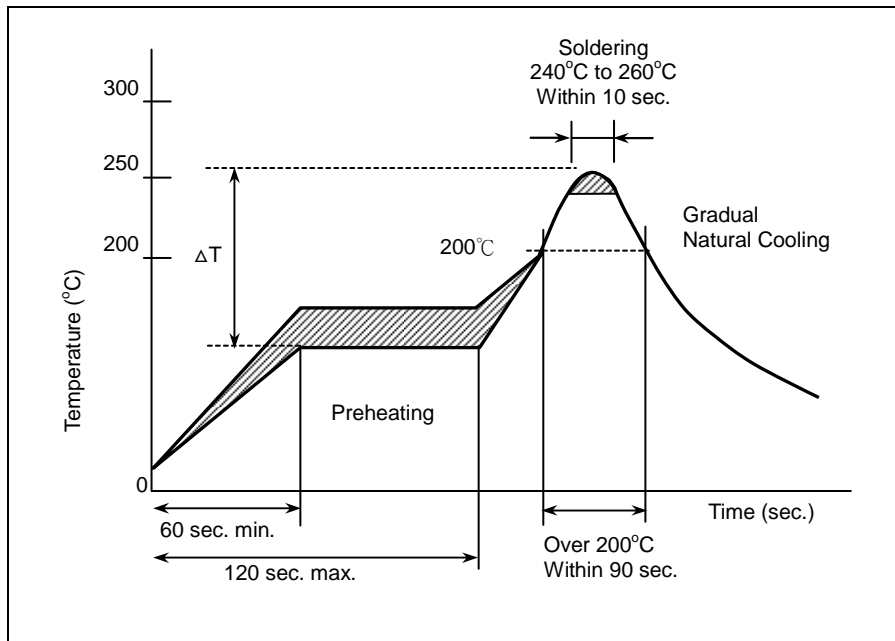

The difference between solder and chip surface should be controlled as following table. The rate of preheat should not exceed 4°C/sec and a target of 2°C/sec is preferred.

Chip Size	3216 and smaller	3225 and above
Preheating	$\Delta T \leq 150^\circ\text{C}$	$\Delta T \leq 130^\circ\text{C}$

Flow Soldering for Lead free Termination

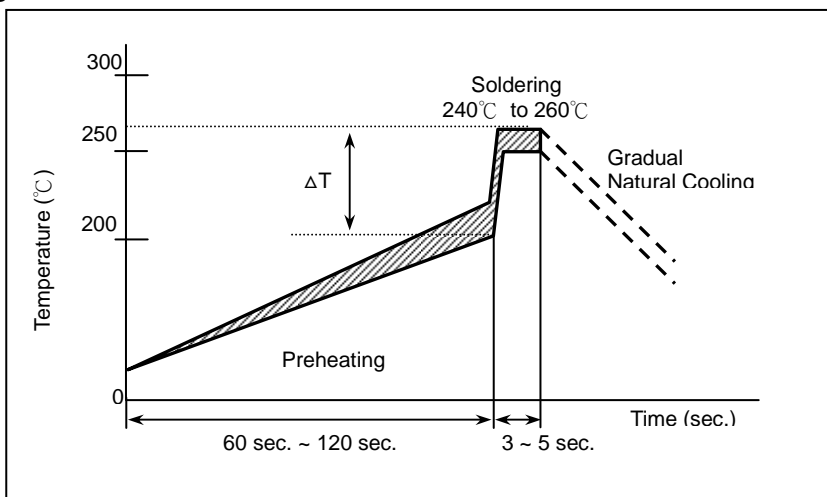

Chip Size	3216 and smaller	3225 and above
Preheating	$\Delta T \leq 150^\circ\text{C}$	-

Soldering Iron

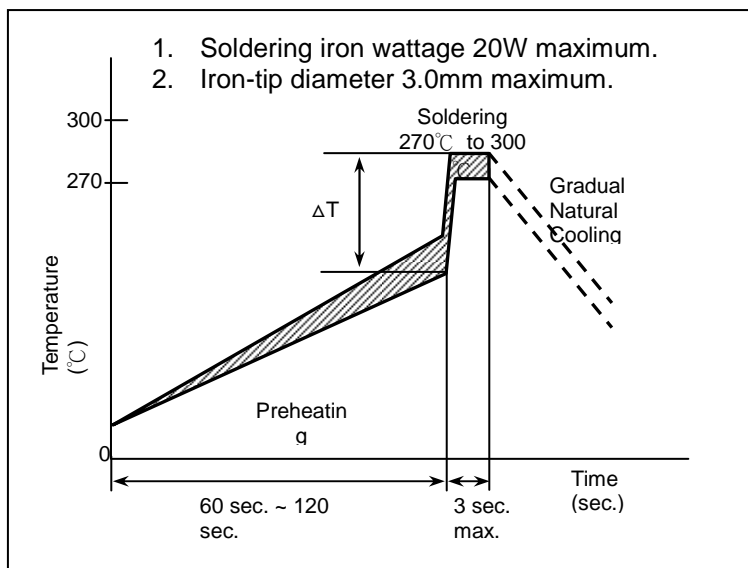

Chip Size	3216 and smaller	3225 and above
Preheating	$\Delta T \leq 190^{\circ}\text{C}$	$\Delta T \leq 130^{\circ}\text{C}$

【Chip Layout and Breaking PCB】

- To layout the SMD capacitors for reducing bend stress from board deflection of PCB. The following are examples of Hood and bad layout.

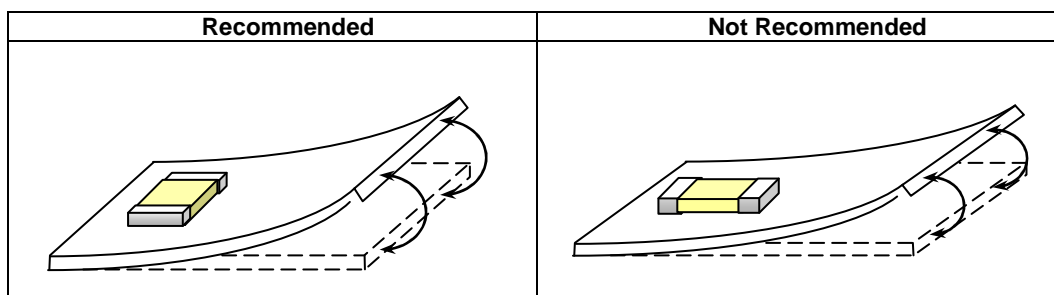

- When breaking PCB, the layout should be noted that the mechanical stresses are depending on the position of capacitors. The following example shows recommendation for better design.

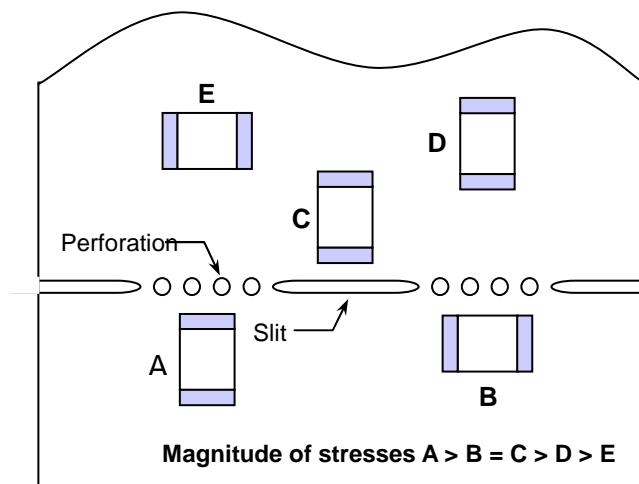

【Aging Rate】

The capacitance and dissipation factor of class 2 capacitors decreases with time. It is known as 'aging' that follows a logarithmic law and expressed in terms of an aging constant. Aging is caused by a gradual re-alignment of the crystalline structure of the ceramic. The aging constant is defined as the percentage loss of capacitance at a 'time decade'. The law of capacitance aging is expressed as following equation:

Typical Curve of Aging Rate of Different Dielectric Material

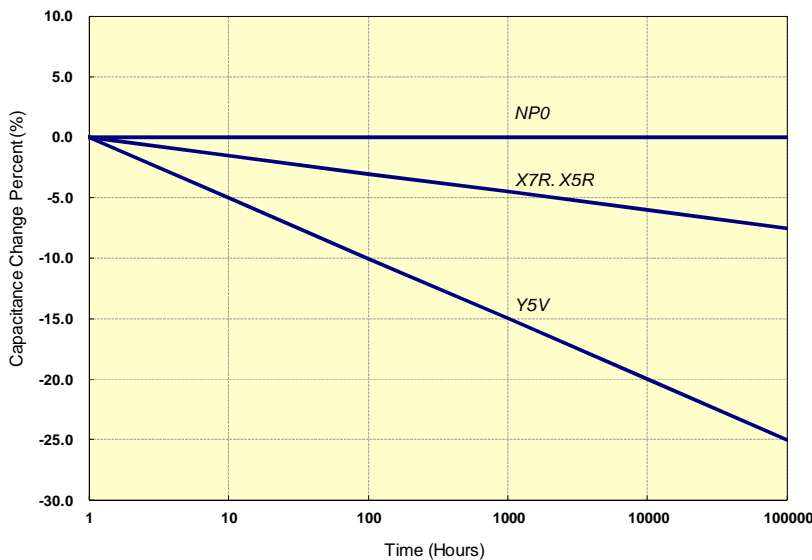

$$C_{t_2} = C_{t_1} \times (1 - k \times \log_{10}(t_2/t_1))$$

C_{t_1} : Capacitance after t_1 hours of start aging.

C_{t_2} : Capacitance after t_2 hours of start aging.

k : aging constant (capacitance decrease per decade)

t_1, t_2 : time in hours from start of aging.

A typical curve of aging rate is shown in following figure.

When heating the capacitors above Curie temperature ($130^{\circ}\text{C} \sim 150^{\circ}\text{C}$) the capacitance can be re-new. So capacitance of class 2 capacitors will be complete de-aged by soldering process; subsequently a new aging process begins.

Because of aging, it is specified an age for measurement to meet the prescribed tolerance for class 2 capacitors. Normally, 1000 hours ($t_2=1000$ hrs) is defined.

【Peeling Off Force】

Peeling off force: 0.1N to 1.0N^* in the direction shown as below.

The peeling speed: 300 ± 10 mm/min

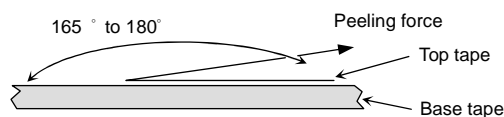

1. The taped tape on reel is wound clockwise. The sprocket holes are to the right as the tape is pulled toward the user.
2. There are minimum 150 mm as the leader and minimum 40 mm empty tape as the tail is attached to the end of the tape.