

TPC
Thermistors NTC

Contents



Thermistors NTC

General Characteristics 2

Application Notes 6

Selection Guide 8

Ordering Code 9

SMD Thermistors NTC

NC 12 - NC 20 10

With Nickel Barrier Termination NB 12 - NB 20 - NB 21 12

Accurate NTC 14

NJ 28 - NI 28 - NK 20 14

Disc Thermistors NTC

General Purpose: ND 03 / Professional: NV 03 16

General Purpose: ND 06 / Professional: NV 06 18

General Purpose: ND 09 / Professional: NV 09 20

Leadless Disc Thermistors NTC 22

Insulated Metal Case: NM 06 24

Table of Values: NM 06 25

Inrush Current Limiters Thermistors NTC

NF 08 - 10 - 13 - 15 - 20 26

Ring Thermistors NTC

NA 19 - NL 19 - NA 57 - NL 57 28

Resistance

Temperature Characteristics 30

Manufacturing Process 34

Reliability 35

Packaging 36

As we are anxious that our customers should benefit from the latest developments in the technology and standards, AVX reserves the right to modify the characteristics published in this brochure.

NOTICE: Specifications are subject to change without notice. Contact your nearest AVX Sales Office for the latest specifications. All statements, information and data given herein are believed to be accurate and reliable, but are presented without guarantee, warranty, or responsibility of any kind, expressed or implied. Statements or suggestions concerning possible use of our products are made without representation or warranty that any such use is free of patent infringement and are not recommendations to infringe any patent. The user should not assume that all safety measures are indicated or that other measures may not be required. Specifications are typical and may not apply to all applications.

Thermistors NTC

General Characteristics

1 – INTRODUCTION

NTC thermistors are thermally sensitive resistors made from a mixture of Mn, Ni, Co, Cu, Fe oxides. Sintered ceramic bodies of various sizes can be obtained. Strict conditions of mixing, pressing, sintering and metallization ensure an excellent batch-to-batch product characteristics.

This semi-conducting material reacts as an NTC resistor, whose resistance decreases with increasing temperature. This Negative Temperature Coefficient effect can result from an external change of the ambient temperature or an internal heating due to the Joule effect of a current flowing through the thermistor.

By varying the composition and the size of the thermistors, a wide range of resistance values (0.1 to 106) and temperature coefficients (-2 to -6% per °C) can be achieved.

2 – MAIN CHARACTERISTICS

2.1 CHARACTERISTICS WITH NO DISSIPATION

2.1.1. Nominal Resistance (Rn)

The nominal resistance of an NTC thermistor is generally given at 25°C. It has to be measured at near zero power so that the resultant heating only produces a negligible measurement error.

The following table gives the maximum advised measurement voltage as a function of resistance values and thermal dissipation factors.

This voltage is such that the heating effect generated by the measurement current only causes a resistance change of $\frac{\Delta R_n}{R_n}$ 1%.

Ranges of values (Ω)	Maximum measuring voltage (V)			
	δ = 2 mW/°C	δ = 5 mW/°C	δ = 10 mW/°C	δ = 20 mW/°C
R 10				0.10
10 < R 100		0.13	0.18	0.24
100 < R 1,000	0.25	0.38	0.53	0.24
1,000 < R 10,000	0.73	1.1	1.5	2.0
10,000 < R 100,000	2.1	3.2	4.6	
R < 100,000	6.4	9.7	14.5	

2.1.2. Temperature - Resistance characteristics R (T)

This is the relation between the zero power resistance and the temperature. It can be determined by experimental measurements and may be described by the ratios R (T) /R (25°C) where:

R (T) is the resistance at any temperature T
R (25°C) is the resistance at 25°C.

These ratios are displayed on pages 30 to 33.

2.1.3. Temperature coefficient (α)

The temperature coefficient (α) which is the slope of the curve at a given point is defined by:

$$\alpha = \frac{100}{R} \cdot \frac{dR}{dT} \text{ and expressed in \% per } ^\circ\text{C}.$$

2.1.4. Sensibility index (B)

The equation $R = A \exp (B/T)$ may be used as a rough approximation of the characteristic R (T).

B is called the sensitivity index or constant of the material used.

To calculate the B value, it is necessary to know the resistances R₁ and R₂ of the thermistor at the temperatures T₁ and T₂.

$$\text{The equation: } R_1 = R_2 \exp B \left(\frac{1}{T_1} - \frac{1}{T_2} \right)$$

$$\text{leads to: } B (K) = \frac{1}{\left(\frac{1}{T_1} - \frac{1}{T_2} \right)} \cdot \ln \left(\frac{R_1}{R_2} \right)$$

Conventionally, B will be most often calculated for temperatures T₁ = 25°C and T₂ = 85°C (298.16 K and 358.16 K).

In fact, as the equation $R = A \exp (B/T)$ is an approximation, the value of B depends on the temperatures T₁ and T₂ by which it is calculated.

For example, from the R (T) characteristic of material M (values given on page 33), it can be calculated:

$$\begin{aligned} B (25 - 85) &= 3950 \\ B (0 - 60) &= 3901 \\ B (50 - 110) &= 3983 \end{aligned}$$

When using the equation $R = A \exp (B/T)$ for this material, the error can vary by as much as 9% at 25°C, 0.6% at 55°C and 1.6% at 125°C.

Using the same equation, it is possible to relate the values of the index B and the coefficient α:

$$\alpha = \frac{1}{R} \cdot \frac{dR}{dT} = \frac{1}{A \exp (B/T)} \cdot A \exp (B/T) \cdot \frac{-B}{T^2}$$

$$\text{thus } \alpha = - \frac{B}{T^2} \text{ expressed in \% } ^\circ\text{C}$$

Thermistors NTC

General Characteristics

2.1.5. Further approximation of R (T) curve

The description of the characteristic R (T) can be improved by using a greater number of experimental points, and by using the equation:

$$\frac{1}{T} = A + B (\ln R) + C (\ln R)^3$$

The parameters A, B and C are determined by solving the set of equations obtained by using the measured resistances at three temperatures.

The solution of the above equation gives the resistance at any temperature:

$$\ln \left[\frac{R(T)}{R(25)} \times 100 \right] = \frac{1}{3} \left[\sqrt[3]{-\frac{27(A-1/T)}{C} + \frac{3}{2} \sqrt{3 \left(\sqrt{27 \left(\frac{A-1/T}{C} \right)^2 + 4 \left(\frac{B}{C} \right)^3} \right)}} - \sqrt[3]{-\frac{3}{2} \sqrt{27 \left(\frac{A-1/T}{C} \right)^2 + 4 \left(\frac{B}{C} \right)^3} + \frac{3}{2} \sqrt{3 \left(\sqrt{27 \left(\frac{A-1/T}{C} \right)^2 + 4 \left(\frac{B}{C} \right)^3} \right)}} \right]$$

The precision of this description is typically 0.2°C for the range -50 to +150°C (A, B, C being determined with experimental values at -20, +50 and 120°C) or even better if this temperature range is reduced. The ratios R(T)/R(25°C) for each of the different materials shown on pages 30 to 33 have been calculated using the above method.

2.1.6. Resistance tolerance and temperature precision

An important characteristic of a thermistor is the tolerance on the resistance value at a given temperature.

This uncertainty on the resistance ($\Delta R/R$) may be related to the corresponding uncertainty on the temperature (ΔT), using the relationship:

$$\Delta T = 100 \cdot \frac{\Delta R}{R} \cdot \frac{1}{\alpha}$$

Example: consider the thermistor ND06M00152J —

- R (25°C) = 1500 ohms
- Made from M material
- R (T) characteristic shown on page 33 gives:
 $\alpha = -4.4\%/^{\circ}\text{C}$ at 25°C
- Tolerance $\Delta R/R = \pm 5\%$ is equivalent to:
 $\Delta T = 5\%/4.4\%/^{\circ}\text{C} = \pm 1.14^{\circ}\text{C}$

2.1.7. Resistance tolerance at any temperature

Any material used for NTC manufacturing always displays a dispersion for the R (T) characteristic.

This dispersion depends on the type of material used and has been especially reduced for our accuracy series thermistors.

Thus, the tolerance on the resistance ($\Delta R_2/R_2$) at a temperature T_2 is the sum of two contributions as illustrated on Figure 1:

- the tolerance $\Delta R_1/R_1$ at a temperature T_1 used as a reference.
- an additional contribution due to the dispersion on the characteristic R (T) which may be called “Manufacturing tolerance” (Tf).

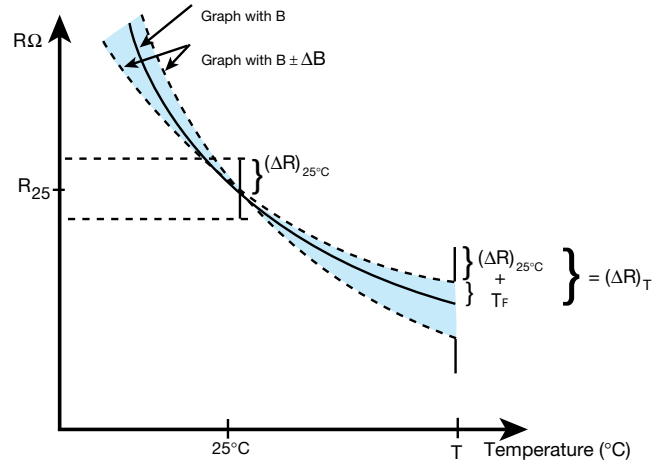

Figure 1

Differentiating the equation $R = A \exp(B/T)$, the two contributions on the tolerance at T can also be written:

$$\frac{\Delta R_2}{R_2} = \frac{\Delta R_1}{R_1} + \left| \frac{1}{T_1} - \frac{1}{T_2} \right| \cdot \Delta B$$

The T(f) values given with the resistance – temperature characteristics on pages 30 to 33 are based on a computer simulation using this equation and experimental values.

2.1.8. Designing the resistance tolerances

Using the fact that the coefficient α decreases with temperature ($\alpha = -B/T^2$), it is generally useful to define the closest tolerance of the thermistor at the maximum value of the temperature range where an accuracy in °C is required.

For example, let us compare the two designs 1 and 2 hereafter:

T (°C)	R (Ω)	α (%/°C)	Design 1		Design 2	
			ΔR/R(%)	ΔT(°C)	ΔR/R(%)	ΔT(°C)
0	3275	-5.2	3.5	0.7	5.0	1.0
25	1000	-4.4	3.0	0.7	4.5	1.1
55	300	-3.7	3.5	1.0	4.0	1.1
85	109	-3.1	4.1	1.3	3.4	1.1
100	69.4	-2.9	4.5	1.6	3.0	1.0

Only the Design 2 is able to meet the requirement $\Delta T \approx 1^{\circ}\text{C}$ from 25°C to 100°C.

Thermistors NTC

General Characteristics

2.1.9. Shaping of the R (T) characteristic

By the use of a resistor network, it is possible to modify the R (T) characteristic of a thermistor so that it matches the required form, for example a linear response over a restricted temperature range.

A single fixed resistor R_p placed in parallel with a thermistor gives a S-shape resistance-temperature curve (see Figure 2) which is substantially more linear at the temperature range around the inflexion point (R_0 , T_0).

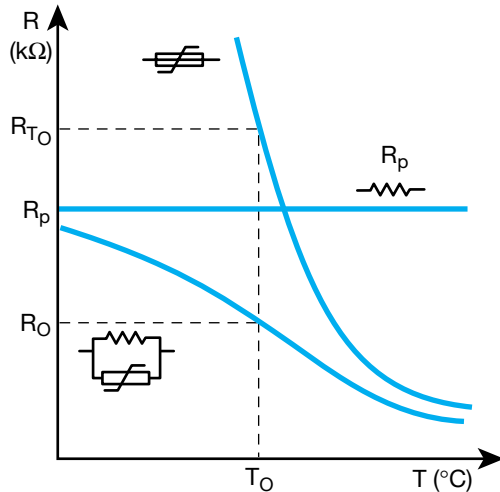

Figure 2 – Linearization of a thermistor

It can be calculated that better linearization is obtained when the fixed resistor value and the mid-range temperature are related by the formula:

$$R_p = R_{T_0} \times \frac{B - T_0}{B + 2T_0}$$

For example, with a thermistor ND03N00103J —

$$R_{25^\circ\text{C}} = 10\text{k}\Omega, B = 4080 \text{ K}$$

good linearization is obtained with a resistor in parallel where the value is:

$$R_p = 10,000 \Omega \times \frac{4080 - 298}{4080 + (2 \times 298)} = 8088 \Omega$$

2.1.10. Demonstration of the R (T) parameters calculation

To help our customers when designing thermistors for temperature measurement or temperature compensation, software developed by our engineering department is available upon request.

2.2 CHARACTERISTICS WITH ENERGY DISSIPATION

When a current is flowing through an NTC thermistor, the power due to the Joule effect raises the temperature of the NTC above ambient.

The thermistor reaches a state of equilibrium when the power supplied becomes equal to the power dissipated in the environment.

The thermal behavior of the thermistor is mainly dependent on the size, shape and mounting conditions.

Several parameters have been defined to characterize these properties:

2.2.1. Heat capacity (H)

The heat capacity is the amount of heat required to change the temperature of the thermistor by 1°C and is expressed in J/°C.

2.2.2. Dissipation factor (δ)

This is the ratio between the variation in dissipated power and the variation of temperature of the NTC. It is expressed in mW/°C and may be measured as:

$$\delta = \frac{U.I}{85 - 25}$$

where U.I is the power necessary to raise to 85°C the temperature of a thermistor maintained in still air at 25°C.

2.2.3. Maximum permissible temperature (T max)

This is the maximum ambient temperature at which the thermistor may be operated with zero dissipation. Above this temperature, the stability of the resistance and the leads attachment can no longer be guaranteed.

2.2.4. Maximum permissible power at 25°C (Pmax)

This is the power required by a thermistor maintained in still air at 25°C to reach the maximum temperature for which it is specified.

For higher ambient temperatures, the maximum permissible power is generally derated according to the Figure 3 hereafter and $T_L = T_{max} - 10^\circ\text{C}$.

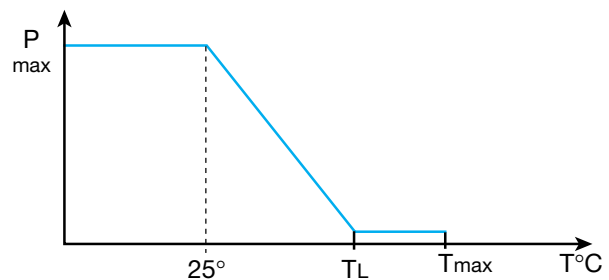

Figure 3 – Derating of maximum power

Thermistors NTC

General Characteristics

2.2.5. Voltage – Current curves V (I)

These curves describe the behavior of the voltage drop V measured across the NTC as the current I through the NTC is increased.

They describe the state of equilibrium between power resulting from Joule effect and dissipated power in the surroundings.

They are displayed on page 29 for different models of thermistors and illustrated on Figure 4.

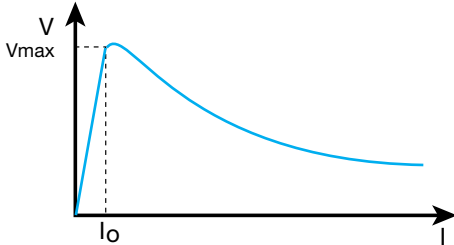

Figure 4 – Voltage – current curve V (I)

Several zones can be identified:

- low current zone
dissipated energy only produces negligible heating and the curve V (I) is almost linear.
- non-linear zone
the curve V (I) displays a maximum voltage Vmax for a current Io. This maximum voltage Vmax and the temperature Tmax reached by the NTC under these conditions can be determined by using the equations:

$$P = U^2/R = \delta (T - T_{amb}) \quad \text{and}$$

$$R = R_{amb} \cdot \exp B (1/T - 1/T_{amb})$$

therefore:

$$T_{max} = B/2 - \sqrt{B^2/4 - BT_{amb}} \approx T_{amb} \left(\frac{1+T_{amb}}{B} \right)$$

$$V_{max} = \sqrt{\delta (T_{max} - T_{amb}) \cdot R_{amb} \exp \left[B \left(\frac{1}{T_{max}} - \frac{1}{T_{amb}} \right) \right]}$$

where δ is the dissipation factor and T_{amb} is the ambient temperature.

- high current zone
for higher currents, an increase in temperature of the NTC decreases the resistance and the voltage more rapidly than the increase of the current. Above a certain dissipated power, the temperature of the NTC exceeds the permissible value.

2.2.6. Current – Time curves I(t)

When voltage is applied to a thermistor, a certain amount of time is necessary to reach the state of equilibrium described by the V(I) curves.

This is the heating up time of the thermistor which depends on the voltage and the resistance on one side and the heat capacity and dissipation on the other.

The curves I(t) are of particular interest in timing applications.

2.2.7. Thermal time constant

When a thermistor is self-heated to a temperature T above ambient temperature T_{amb} , and allowed to cool under zero power resistance, this will show a transient situation.

At any time interval dt, dissipation of the thermistor ($\delta(T - T_{amb})dt$) generates a temperature decrease $-HdT$, resulting in the equation:

$$\frac{1}{(T - T_{amb})} dT = - \frac{\delta}{H} dt$$

The solution to this equation for any value of t, measured from t = 0, is:

$$\ln \frac{(T - T_{amb})}{(T_0 - T_{amb})} = - \frac{\delta}{H} t$$

We can define a thermal time constant τ as:

$$\tau = H/\delta \quad \text{expressed in seconds.}$$

Where the time t = τ :

$$(T - T_{amb}) / (T_0 - T_{amb}) = \exp - 1 = 0.368$$

expressing that for t = τ , the thermistor cools to 63.2% of the temperature difference between the initial T_0 and T_{amb} (see Figure 5).

According to IEC 539 our technical data indicates τ measured with $T_0 = 85^\circ\text{C}$, $T_{amb} = 25^\circ\text{C}$ and consequently $T = 47.1^\circ\text{C}$.

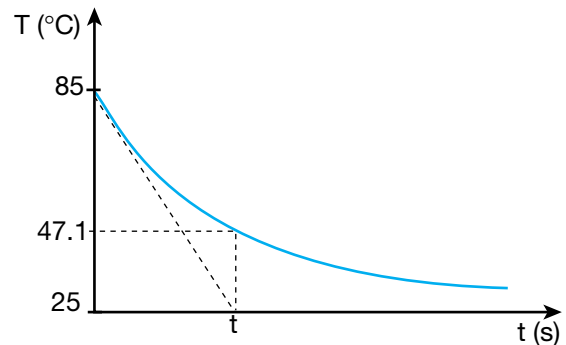

Figure 5 – Temperature – time curve T(t)

2.2.8. Response time

More generally, it is possible to define a response time as the time the thermistor needs to reach 63.2% of the total temperature difference when submitted to a change in the thermal equilibrium (for example from 60°C to 25°C in silicone oil 47V20 Rhodorsil).

Thermistors NTC

Application Notes

TEMPERATURE MEASUREMENT

High sensitivity and low cost make NTC thermistors the most common device used for temperature measurement.

Non-linearity of the R - T curve generally leads to the use of a resistor network to linearize the signal. An example is given in Figure 6.

More precise measurements and temperature display can also be achieved with simple electronic equipment as shown in Figure 7.

The choice of the model will particularly take into account the small size (better response time) and the resistance tolerance. Mounting conditions (dissipation), and input voltage (self-heating) will also be carefully defined to avoid serious errors in temperature measurement.

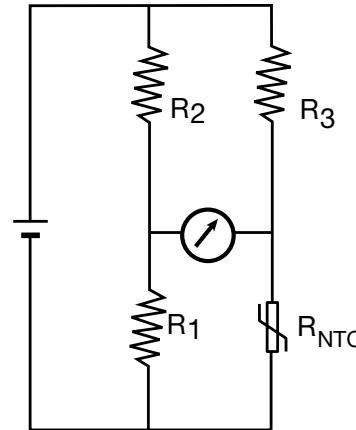

Figure 6

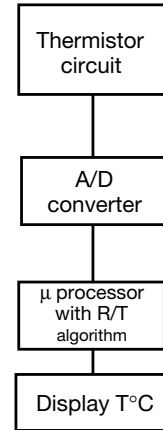

Figure 7

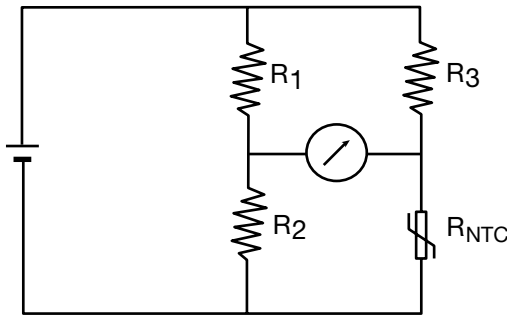

Figure 8

TEMPERATURE CONTROL AND ALARM

NTC thermistors can be used as a simple on-off control temperature system or temperature alarm system. Figure 8 gives an example of such a circuit.

When the temperature increases to a defined value, the resistance of the thermistor decreases and the current becomes sufficiently high to energize the relay and provide temperature alarm or heating system turn-off.

The high sensitivity of thermistors (about 4% resistance change for 1°C) allows the temperature to be controlled very precisely.

TEMPERATURE COMPENSATION

As many electronic components (integrated circuits, amplifiers,...) have a positive temperature coefficient of resistance, NTC thermistors represent a cheap and interesting solution to compensate for this effect and provide an improved temperature stability for electronic equipment.

It is necessary to include the thermistor in a resistor network (Figure 10) calculated in such a manner that the network coefficient compensates exactly for the positive temperature coefficient of the other component (Figure 9).

Common leaded discs or chip thermistors are well suited for this application.

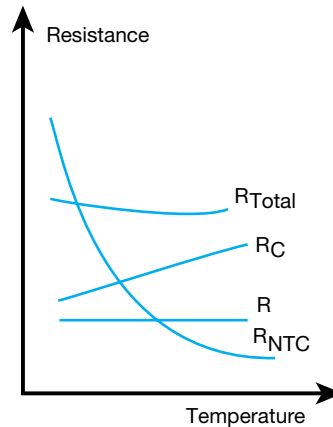

Figure 9

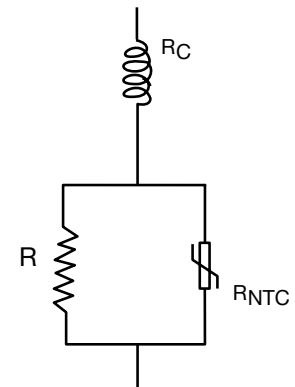

Figure 10

Thermistors NTC

Application Notes

LIQUID LEVEL OR FLOW DETECTION

The dissipation of a thermistor is significantly different in a liquid or in a gas, in a static fluid or in a stirred one. A liquid level detector or a gas-flow measurement can be designed using this property.

In Figure 11, the output voltage measured on the thermistor depends upon the dissipation factor of its environment, and can be illustrated by V-I curves (Figure 12).

This voltage can be used to detect the presence (V_2) or absence (V_1) of liquid around the thermistor or measure the flow speed.

A good design should define a precise operating temperature range, where dissipation in the high dissipating medium at highest ambient temperature remains higher than the dissipation in low dissipating medium at lowest ambient temperature.

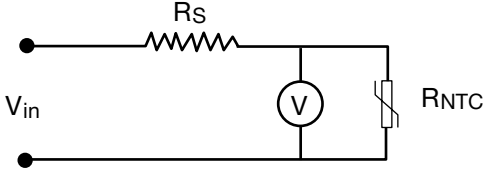

Figure 11

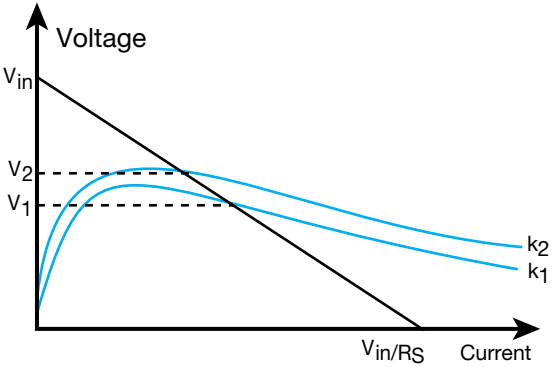

Figure 12

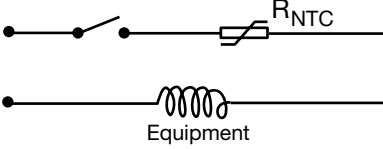

Figure 13

SURGE PROTECTION

A soft start of sensitive apparatus can be achieved by using NTC thermistors as described in Figures 13 and 14.

At turn-on, the NTC absorbs the surge current, limits the current across the equipment and protects it. Then, the thermistor heats, its resistance decreases and most of the power becomes applied to the apparatus.

In its design, the thermistor will be selected with a thermal capacity higher than the surge energy to absorb.

This property is useful when using NTC thermistor as inrush current limiter for switching power supplies (see on page 26).

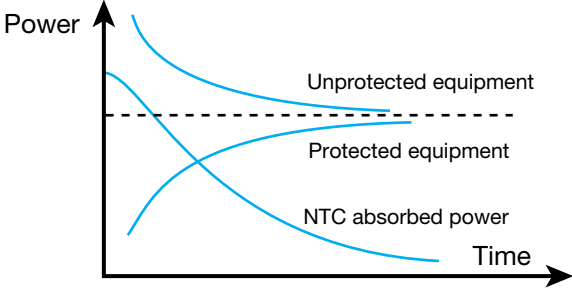

Figure 14

TIME DELAY

The current-time characteristic of a thermistor is used in time delay applications such as delaying energization of a relay after application of power to an electrical circuit.

The time delay, time necessary for the thermistor to heat up to the temperature where its resistance allows the current to reach the switching value of the relay, is mainly defined with the nominal resistance of the thermistor.

The time delay is also strongly dependent upon the ambient temperature, as shown in Figure 15.

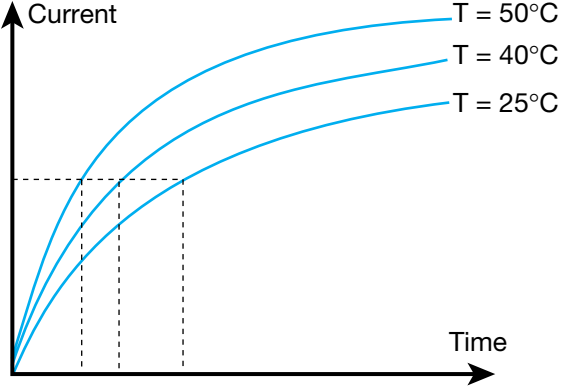





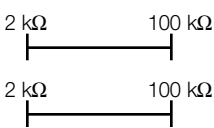



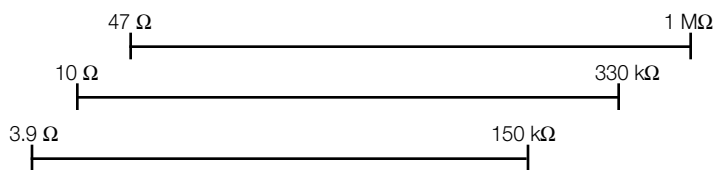



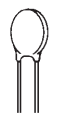
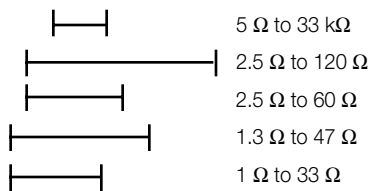

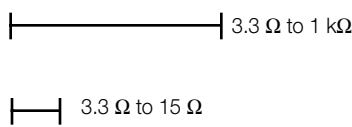
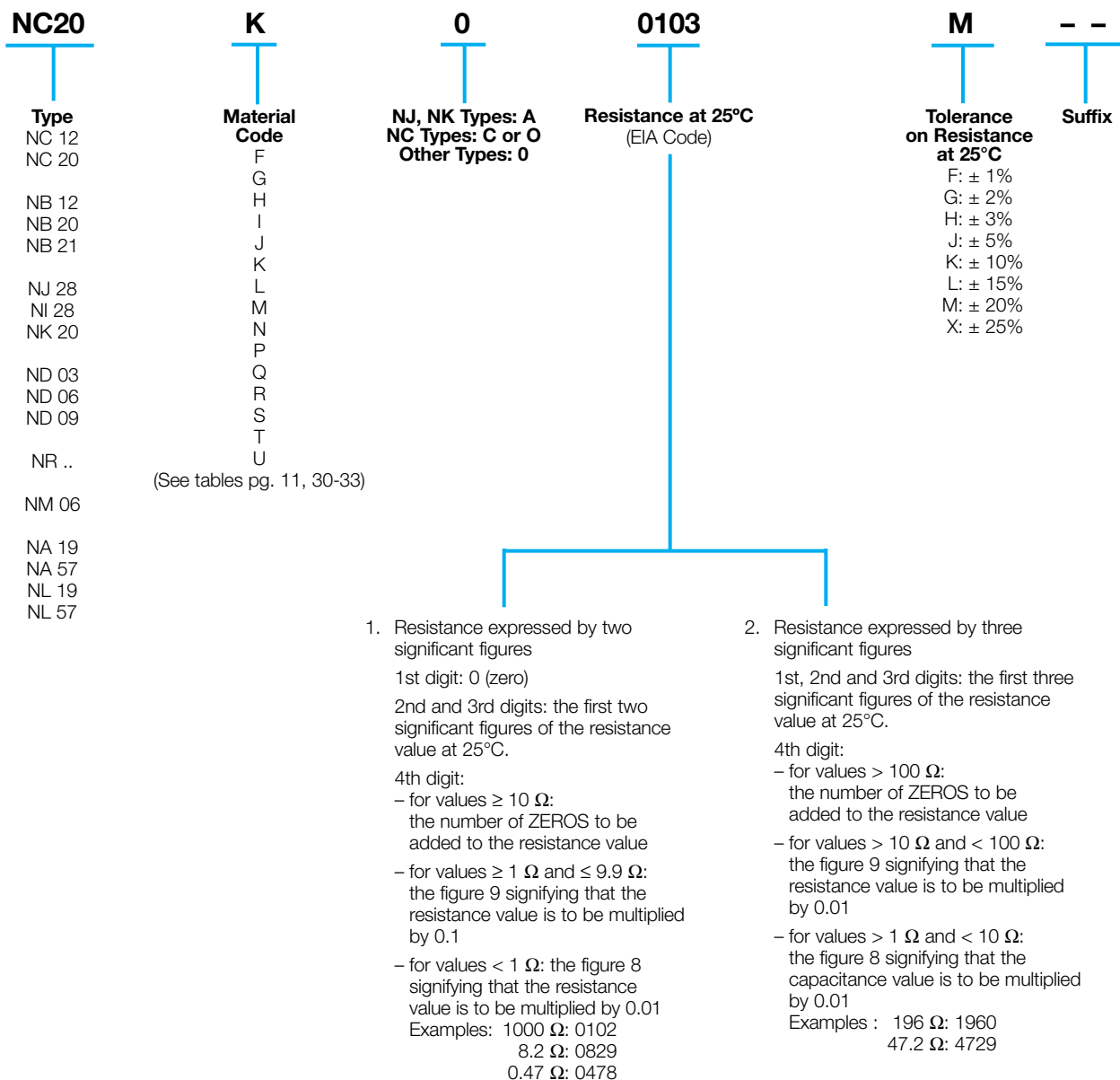

Figure 15

Types	Range of Values R at 25°C	Main Applications	Page
SMD NC12/20 NB12/20/21 		<ul style="list-style-type: none"> - Hybrid circuit - Temperature Compensation 	10 12
Accuracy Series NJ28 NI 28 NK20   		<ul style="list-style-type: none"> - Temperature measurement 	14
Leaded Discs N.03 N.06 N.09   		<ul style="list-style-type: none"> - Temperature measurement and regulation - Level detection - Compensation 	16 18 20
Leadless Discs NR 	Custom designed products generally defined at two temperatures	<ul style="list-style-type: none"> - Automotive and industrial thermal control 	22
Insulated Case NM06 		<ul style="list-style-type: none"> - Temperature measurement and regulation - Compensation 	24
Inrush Current Limiters NF 08 NF 10 NF 13 NF 15 NF 20 		<ul style="list-style-type: none"> - Current limitation - Delay circuit 	26
Rings NA/NL 19 NA/NL 57  		<ul style="list-style-type: none"> - Power modules protection 	28

Ordering Code

HOW TO ORDER



For leadless discs (types NR) see specification and ordering code on pages 22-23.

SMD Thermistors NTC



NC 12 – NC 20

Chip thermistors are a high quality and low cost device especially developed for surface mounting applications. They are widely used for temperature compensation but can also achieve temperature control of printed circuits. Its silver -

palladium - platinum metallization provides a high degree of resistance to dewetting of the terminations during soldering (typically 260°C / 30 s).

Types	NC 12 IEC SIZE : 08-05	NC 20 IEC SIZE : 12-06
DIMENSIONS: millimeters (inches)		
Terminations	Silver – palladium – platinum metallization	
Marking	On packaging only	
Climatic category	40/125/56	
Operating temperature	-55°C to +150°C	
Tolerance on R _n (25°C)	±5%, ±10%, ±20%	
Maximum dissipation at 25°C	0.12 W	0.24 W
Thermal dissipation factor	2 mW/°C	4 mW/°C
Thermal time constant	5 s	7 s

Resistance - Temperature characteristics: pages 30 to 32.

APPLICATIONS

- LCD compensation
- Battery packs
- Mobile phones
- CD players
- Heating systems
- Air-conditioning systems
- Temperature control of Switch Mode Power Supplies
- Compensation of pressure sensors
- Protection of power transistors in various electronic circuits

HOW TO ORDER

NC 20

Type

K 0

Material Code
K
(See tables pg. 11, 30-33)

0103

Resistance
10,000 Ω

M

Tolerance
M (±20%)

BA

Suffix: Packaging
--: Bulk
BA: Super 8 plastic tape
BE: Super 8 plastic tape (1/2 reel)

SMD Thermistors NTC



NC 12 – NC 20

TABLE OF VALUES

NC 12 IEC SIZE : 08-05				
Types	Rn at 25°C ()	Material Code	B (K) (1) ± 5% (2) ± 3%	α at 25°C (%/°C)
NC 12 KC 0 180	18	KC	3470 (1)	- 3.9
NC 12 KC 0 220	22			
NC 12 KC 0 270	27			
NC 12 KC 0 330	33			
NC 12 KC 0 390	39			
NC 12 KC 0 470	47			
NC 12 KC 0 560	56			
NC 12 KC 0 680	68			
NC 12 KC 0 820	82			
NC 12 KC 0 101	100			
NC 12 MC 0 121	120	MC	3910 (1)	- 4.4
NC 12 MC 0 151	150			
NC 12 MC 0 181	180			
NC 12 MC 0 221	220			
NC 12 MC 0 271	270			
NC 12 MC 0 331	330			
NC 12 MC 0 391	390			
NC 12 MC 0 471	470			
NC 12 MC 0 561	560			
NC 12 MC 0 681	680			
NC 12 MC 0 821	820			
NC 12 MC 0 102	1,000			
NC 12 MC 0 122	1,200			
NC 12 MC 0 152	1,500			
NC 12 MC 0 182	1,800			
NC 12 MC 0 222	2,200			
NC 12 MC 0 272	2,700			
NC 12 MC 0 332	3,300			
NC 12 J 0 0392	3,900	J	3480 (1)	- 3.9
NC 12 J 0 0472	4,700			
NC 12 J 0 0562	5,600			
NC 12 K 0 0682	6,800	K	3630 (1)	- 4.0
NC 12 K 0 0822	8,200			
NC 12 K 0 0103	10,000			
NC 12 K 0 0123	12,000			
NC 12 L 0 0153	15,000	L	3790 (2)	- 4.2
NC 12 L 0 0183	18,000			
NC 12 M 0 0223	22,000	M	3950 (2)	- 4.4
NC 12 M 0 0273	27,000			
NC 12 M 0 0333	33,000			
NC 12 M 0 0393	39,000			
NC 12 N 0 0473	47,000	N	4080 (2)	- 4.6
NC 12 N 0 0563	56,000			
NC 12 N 0 0683	68,000			
NC 12 N 0 0823	82,000			
NC 12 P 0 0104	100,000			
NC 12 P 0 0124	120,000	P	4220 (2)	- 4.7
NC 12 P 0 0154	150,000			
NC 12 P 0 0184	180,000			
NC 12 Q 0 0224	220,000			
NC 12 Q 0 0224	220,000			

NC 20 IEC SIZE : 12-06							
Types	Rn at 25°C ()	Material Code	B (K) (1) ± 5% (2) ± 3%	α at 25°C (%/°C)			
NC 20 KC 0 100	10	KC	3470 (1)	- 3.9			
NC 20 KC 0 120	12						
NC 20 KC 0 150	15						
NC 20 KC 0 180	18						
NC 20 KC 0 220	22						
NC 20 KC 0 270	27						
NC 20 KC 0 330	33						
NC 20 KC 0 390	39						
NC 20 KC 0 470	47						
NC 20 KC 0 560	56						
NC 20 KC 0 680	68						
NC 20 KC 0 820	82						
NC 20 KC 0 101	100						
NC 20 MC 0 121	120	MC	3910 (1)	- 4.4			
NC 20 MC 0 151	150						
NC 20 MC 0 181	180						
NC 20 MC 0 221	220						
NC 20 MC 0 271	270						
NC 20 MC 0 331	330						
NC 20 MC 0 391	390						
NC 20 MC 0 471	470						
NC 20 MC 0 561	560						
NC 20 MC 0 681	680						
NC 20 MC 0 821	820						
NC 20 MC 0 102	1,000						
NC 20 MC 0 122	1,200						
NC 20 MC 0 152	1,500						
NC 20 I 0 0 182	1,800				I	3340 (1)	- 3.7
NC 20 I 0 0 222	2,200						
NC 20 I 0 0 272	2,700						
NC 20 I 0 0 332	3,300						
NC 20 J 0 0 392	3,900	J	3480 (1)	- 3.9			
NC 20 J 0 0 472	4,700						
NC 20 J 0 0 562	5,600						
NC 20 J 0 0 682	6,800						
NC 20 K 0 0 822	8,200	K	3630 (1)	- 4.0			
NC 20 K 0 0 103	10,000						
NC 20 K 0 0 123	12,000						
NC 20 K 0 0 153	15,000						
NC 20 L 0 0 183	18,000	L	3790 (2)	- 4.2			
NC 20 L 0 0 223	22,000						
NC 20 M 0 0 273	27,000	M	3950 (2)	- 4.4			
NC 20 M 0 0 333	33,000						
NC 20 M 0 0 393	39,000						
NC 20 M 0 0 473	47,000						
NC 20 N 0 0 563	56,000						
NC 20 N 0 0 683	68,000	N	4080 (2)	- 4.6			
NC 20 N 0 0 823	82,000						
NC 20 N 0 0 104	100,000						
NC 20 P 0 0 124	120,000						
NC 20 P 0 0 154	150,000						
NC 20 P 0 0 184	180,000	P	4220 (2)	- 4.7			
NC 20 P 0 0 224	220,000						
NC 20 Q 0 0 274	270,000						
NC 20 Q 0 0 334	330,000						
NC 20 Q 0 0 394	390,000						
NC 20 Q 0 0 474	470,000	Q	4300 (2)	- 4.7			
NC 20 R 0 0 564	560,000						
NC 20 R 0 0 684	680,000						
NC 20 R 0 0 824	820,000						
NC 20 R 0 0 105	1,000,000						

SMD Thermistors NTC



With Nickel Barrier Termination NB 12 - NB 20 - NB 21

Chip thermistors are high quality and low cost devices especially developed for surface mounting applications. They are widely used for temperature compensation but can also achieve temperature control of printed circuits.

A nickel barrier metallization provides outstanding qualities of solderability and enables this chip to meet the requirements of the most severe soldering processes.

Types	NB 21 IEC SIZE : 06-03	NB 12 IEC SIZE : 08-05	NB 20 IEC SIZE : 12-06
DIMENSIONS: millimeters (inches)			
Terminations	Nickel Barrier		
Marking	On packaging only		
Climatic category	40/125/56		
Operating temperature	-55°C to +150°C		
Tolerance on Rn (25°C)	±5%, ±10%, ±20%		
Maximum dissipation at 25°C	0.7 W	0.12 W	0.24 W
Thermal dissipation factor	1 mW/°C	2 mW/°C	4 mW/°C
Thermal time constant	4 s	5 s	7s

Resistance - Temperature characteristics: pages 30 to 32.

APPLICATIONS

- LCD compensation
- Battery packs
- Mobile phones
- CD players
- Heating systems
- Air-conditioning systems
- Temperature control of Switch Mode Power Supplies
- Compensation of pressure sensors
- Protection of power transistors in various electronic circuits

HOW TO ORDER

NB 20



Type

K 0



Material Code

K
(See tables pg. 13, 30-33)

0103



Resistance
10,000 Ω

M



Tolerance
M (±20%)

BA



Suffix: Packaging

--: Bulk
BA: Super 8 plastic tape
BE: Super 8 plastic tape (1/2 reel)

SMD Thermistors NTC



With Nickel Barrier Termination NB 12 – NB 20 – NB 21

TABLE OF VALUES

NB 12 IEC SIZE : 08-05				
Types	Rn at 25°C (Ω)	Material Code	B (K) $(\frac{\Delta B}{B} \begin{matrix} (1) \pm 5\% \\ (2) \pm 3\% \end{matrix})$	α at 25°C (%/°C)
NB 12 KC 0 180	18	KC	3470 (1)	- 3.9
NB 12 KC 0 220	22			
NB 12 KC 0 270	27			
NB 12 KC 0 330	33			
NB 12 KC 0 390	39			
NB 12 KC 0 470	47			
NB 12 KC 0 560	56			
NB 12 KC 0 680	68			
NB 12 KC 0 820	82			
NB 12 KC 0 101	100			
NB 12 MC 0 121	120	MC	3910 (1)	- 4.4
NB 12 MC 0 151	150			
NB 12 MC 0 181	180			
NB 12 MC 0 221	220			
NB 12 MC 0 271	270			
NB 12 MC 0 331	330			
NB 12 MC 0 391	390			
NB 12 MC 0 471	470			
NB 12 MC 0 561	560			
NB 12 MC 0 681	680			
NB 12 MC 0 821	820			
NB 12 MC 0 102	1,000			
NB 12 MC 0 122	1,200			
NB 12 MC 0 152	1,500			
NB 12 MC 0 182	1,800			
NB 12 MC 0 222	2,200			
NB 12 MC 0 272	2,700			
NB 12 MC 0 332	3,300			
NB 12 J 0 5392	3,900	J05	3520 (1)	- 3.9
NB 12 J 0 5472	4,700			
NB 12 J 0 0562	5,600	K	3630 (1)	- 4.0
NB 12 K 0 0682	6,800			
NB 12 K 0 0822	8,200			
NB 12 K 0 0103	10,000			
NB 12 K 0 0123	12,000	L	3790 (2)	- 4.2
NB 12 L 0 0153	15,000			
NB 12 L 0 0183	18,000	M	3950 (2)	- 4.4
NB 12 M 0 0223	22,000			
NB 12 M 0 0273	27,000			
NB 12 M 0 0333	33,000			
NB 12 M 0 0393	39,000	N	4080 (2)	- 4.6
NB 12 N 0 0473	47,000			
NB 12 N 0 0563	56,000			
NB 12 N 0 5683	68,000	N05	4160 (2)	-4.7
NB 12 N 0 5823	82,000			
NB 12 P 0 0104	100,000	P	4220 (2)	- 4.7
NB 12 P 0 0124	120,000			
NB 12 P 0 0154	150,000			
NB 12 P 0 0184	180,000			

NB 20 IEC SIZE : 12-06				
Types	Rn at 25°C (Ω)	Material Code	B (K) $(\frac{\Delta B}{B} \begin{matrix} (1) \pm 5\% \\ (2) \pm 3\% \end{matrix})$	α at 25°C (%/°C)
NB 20 J 0 5392	3,900	J05	3520 (1)	- 3.9
NB 20 J 0 5472	4,700			
NB 20 J 0 5562	5,600			
NB 20 J 0 5682	6,800			
NB 20 K 0 0822	8,200	K	3630 (1)	- 4.0
NB 20 K 0 0103	10,000			
NB 20 K 0 0123	12,000			
NB 20 K 0 0153	15,000	L	3790 (2)	- 4.2
NB 20 L 0 0183	18,000			
NB 20 L 0 0223	22,000	M	3950 (2)	- 4.4
NB 20 M 0 0273	27,000			
NB 20 M 0 0333	33,000			
NB 20 M 0 0393	39,000			
NB 20 M 0 0473	47,000	N	4080 (2)	- 4.6
NB 20 N 0 0563	56,000			
NB 20 N 0 0683	68,000			
NB 20 N 0 0823	82,000			
NB 20 N 0 5104	100,000	N05	4160 (2)	-4.7
NB 20 P 0 0124	120,000	P	4220 (2)	- 4.7
NB 20 P 0 0154	150,000			
NB 20 P 0 0184	180,000			
NB 20 P 0 0224	220,000	Q	4300 (2)	- 4.7
NB 20 Q 0 0274	270,000			
NB 20 Q 0 0334	330,000			
NB 20 Q 0 0394	390,000			
NB 20 Q 0 0474	470,000	R	4400 (2)	- 4.8
NB 20 R 0 0564	560,000			
NB 20 R 0 0684	680,000			
NB 20 R 0 0824	820,000			
NB 20 R 0 0105	1,000,000			

NB 21 IEC SIZE : 06-03				
Types	Rn at 25°C (Ω)	Material Code	B (K) $(\frac{\Delta B}{B} \begin{matrix} (1) \pm 5\% \\ (2) \pm 3\% \end{matrix})$	α at 25°C (%/°C)
NB 21 PC 0 472	4,700	PC	4200 (1)	- 4.7
NB 21 J 0 5103	10,000	J05	3520 (1)	- 3.9
NB 21 K 0 0153	15,000	K	3630 (2)	- 4.0
NB 21 L 0 0223	22,000	L	3790 (2)	- 4.2
NB 21 M 0 0473	47,000	M	3950 (2)	- 4.4
NB 21 N 0 5104	100,000	N05	4160 (2)	- 4.7
NB 21 P 0 0154	150,000	P	4220 (2)	- 4.7

Accurate Thermistors NTC



NJ 28 – NI 28 – NK 20

High precision resistance and an outstanding ability to reproduce the sensibility index B, make these ranges of products the types of thermistors ideal for temperature measurement applications.

Leaded or unleaded, these small size and rapid response time thermistors are able to meet the most accurate requirements.

Types	NJ 28	NI 28	NK 20
Finish	Coated chip with phenolic resin + varnish	Coated chip with epoxy insulated leads	Chip
DIMENSIONS: millimeters (inches)			
Marking	On packaging only		
Operating temperature	-55°C to +150°C		
Tolerance on R _n (25°C)	±1%, ±2%, ±3%		
Maximum dissipation at 25°C	0.16 W		
Thermal dissipation factor*	3 mW/°C	3 mW/°C	2 mW/°C
Thermal time constant	8 s	8 s	6 s
Response time	< 2 s		

TABLE OF VALUES

Types	R _n at 25°C (Ω)	Material Code	B (K)	α at 25°C (%/°C)
N■ 28 KA 0202	2,000	KA	3625 ± 1%	- 4.1
N■ 28 MA 0302	3,000	MA	3960 ± 0.5%	- 4.5
N■ 28 MA 0502	5,000	MA	3960 ± 0.5%	- 4.5
N■ 28 NA 0103	10,000	NA	4100 ± 1%	- 4.6
N■ 28 PA 0203	20,000	PA	4235 ± 1%	- 4.8
N■ 28 QA 0503	50,000	QA	4250 ± 1%	- 4.8
N■ 28 RA 0104	100,000	RA	4380 ± 1%	- 4.9

- = J for non-insulated leads
- = I for insulated leads
- = K for marked chip

Resistance - Temperature characteristics: page 33.

HOW TO ORDER

NJ28
|
Type

MA
|
Material Code
MA
(See table above)

0502
|
Resistance
5 kΩ

F--
|
Tolerance
F (±1%)

Thermistors NTC Manufacturing Process

NJ 28 – NI 28 – NK 20

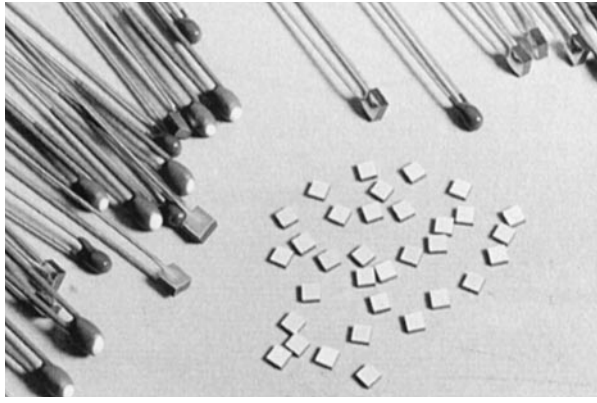
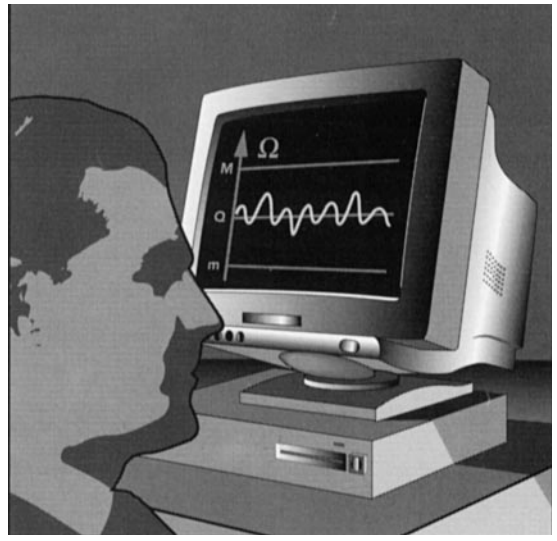
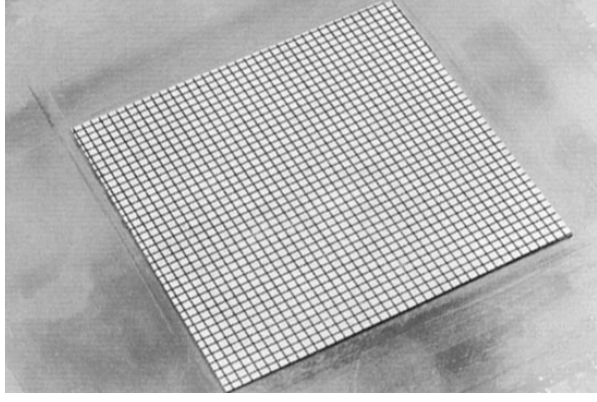
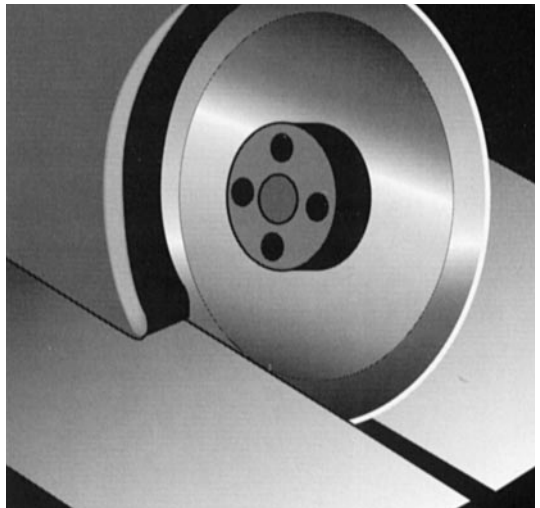
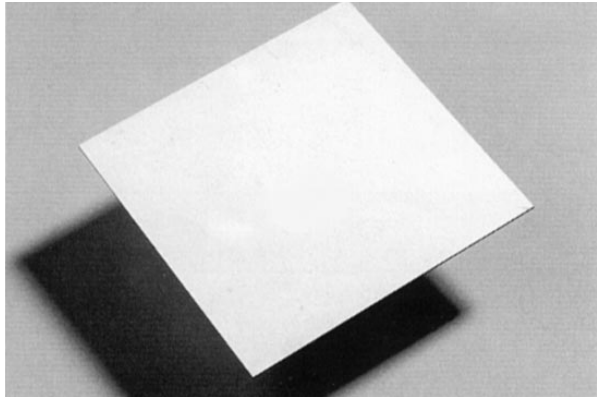
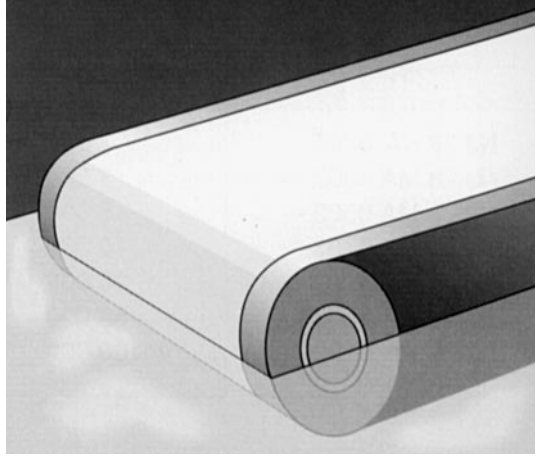

Disc Thermistors NTC

General Purpose: ND 03
Professional: NV 03



High quality and low cost allow these products to cover a large range of control, alarm and temperature measurement applications.

We are ready to satisfy your needs with standard or custom designed product configurations, i.e. : specific lead materials, diameters or packaging requirements.

Types	GENERAL PURPOSE	PROFESSIONAL
	ND 03	NV 03
Finish	Coated disc with phenolic resin	Varnished disc
Standards		In accordance with NFC 93271 Type: TN117 List: GAM-T1
DIMENSIONS: millimeters (inches)		
Marking	On package only	
Climatic category	–	25/125/56 (635)
Operating temperature	-55°C to +150°C	-55°C to +150°C
Tolerance on Rn (25°C)	47Ω to 1MΩ: ±5%, ±10%, ±20% 1500Ω to 150 kΩ: ±3%	47Ω to 1MΩ: ±5%, ±10% 1500Ω to 150 kΩ: ±3%
Maximum dissipation at 25°C	0.25 W	0.18 W
Thermal dissipation factor	5 mW/°C	3 mW/°C
Thermal time constant	10 s	8 s
Response Time	< 3 s	< 3 s

Table of Values

General Purpose: ND 03
Professional: NV 03



Types	Rn at 25°C ()	Material Code	B (K) ($\frac{\Delta B}{B}$ ^{(1) ± 5%} _{(2) ± 3%})	α at 25°C (%/°C)
N■ 03 F 0 0470 N■ 03 F 0 0680	47 68	F	2800 (1)	- 3.2
N■ 03 G 0 0101 N■ 03 G 0 0151	100 150	G	3030 (1)	- 3.4
N■ 03 H 0 0221	220	H	3160 (1)	- 3.5
N■ 03 I 0 0331 N■ 03 I 0 0471	330 470	I	3340 (1)	- 3.7
N■ 03 J 0 0681 N■ 03 J 0 0102	680 1,000	J	3480 (1)	- 3.9
N■ 03 K 0 0152 N■ 03 K 0 0222	1,500 2,200	K	3630 (1)	- 4.0
N■ 03 L 0 0332	3,300	L	3790 (2)	- 4.2
N■ 03 M 0 0472 N■ 03 M 0 0682	4,700 6,800	M	3950 (2)	- 4.4
N■ 03 N 0 0103 N■ 03 N 0 0153	10,000 15,000	N	4080 (2)	- 4.6
N■ 03 P 0 0223 N■ 03 P 0 0333	22,000 33,000	P	4220 (2)	- 4.7
N■ 03 Q 0 0473 N■ 03 Q 0 0683	47,000 68,000	Q	4300 (2)	- 4.7
N■ 03 R 0 0104 N■ 03 R 0 0154	100,000 150,000	R	4400 (2)	- 4.8
N■ 03 S 0 0224	220,000	S	4520 (2)	- 5.0
N■ 03 T 0 0334 N■ 03 T 0 0474	330,000 470,000	T	4630 (2)	- 5.1
N■ 03 U 0 0105	1,000,000	U	4840 (2)	- 5.3

■ = D for general purpose
■ = V for professional

Resistance - Temperature characteristics: pages 30 to 32.

HOW TO ORDER

ND03

Type

N0

Material Code
N
(See table above)

0103

Resistance
10 kΩ

K --

Tolerance
K (±10%)

Disc Thermistors NTC

General Purpose: ND 06
Professional: NV 06



These multi-purpose thermistors can be used for temperature control, compensation or measurement.

This standard product is available in large quantities and with a short delivery time.

Types	GENERAL PURPOSE	PROFESSIONAL
	ND 06	NV 06
Finish	Coated disc with phenolic resin	Varnished disc
Standards		Approved by NFC 93 271 Type: TN 115 A List: GAM-T1 List: LNZ
DIMENSIONS: millimeters (inches)		
Marking	Nominal resistance Tolerance for $\pm 5\%$, $\pm 10\%$	Nominal resistance Tolerance
Climatic category	–	55/125/56 - 434
Operating temperature	-55°C to +150°C	-55°C to +150°C
Tolerance on Rn (25°C)	$\pm 5\%$, $\pm 10\%$, $\pm 20\%$	$\pm 2\%$, $\pm 5\%$, $\pm 10\%$
Maximum dissipation at 25°C	0.71 W	0.69 W
Thermal dissipation factor	7.1 mW/°C	6.9 mW/°C
Thermal time constant	22 s	18 s

▲ On request = 2.54

Table of Values



ND 06 - NV 06

Types	Rn at 25°C ()	Material Code	B (K) ($\Delta B/B$ ^{(1) ± 5%} _{(2) ± 3%})	α at 25°C (%/°C)
N■ 06 F 0 0100 N■ 06 F 0 0150	10 15	F	2800 (1)	- 3.2
N■ 06 G 0 0220 N■ 06 G 0 0330	22 33	G	3030 (1)	- 3.4
N■ 06 H 0 0470 N■ 06 H 0 0680	47 68	H	3160 (1)	- 3.5
N■ 06 I 0 0101	100	I	3340 (1)	- 3.7
N■ 06 J 0 0151 N■ 06 J 0 0221	150 220	J	3480 (1)	- 3.9
N■ 06 K 0 0331 N■ 06 K 0 0471	330 470	K	3630 (1)	- 4.0
N■ 06 L 0 0681 N■ 06 L 0 0102	680 1,000	L	3790 (2)	- 4.2
N■ 06 M 0 0152	1,500	M	3950 (2)	- 4.4
N■ 06 N 0 0222 N■ 06 N 0 0332	2,200 3,300	N	4080 (2)	- 4.6
N■ 06 P 0 0472 N■ 06 P 0 0682 N■ 06 P 0 0103	4,700 6,800 10,000	P	4220 (2)	- 4.7
N■ 06 Q 0 0153 N■ 06 Q 0 0223	15,000 22,000	Q	4300 (2)	- 4.7
N■ 06 R 0 0333	33,000	R	4400 (2)	- 4.8
N■ 06 S 0 0473 N■ 06 S 0 0683	47,000 68,000	S	4520 (2)	- 5.0
N■ 06 T 0 0104	100,000	T	4630 (2)	- 5.1
N■ 06 U 0 0154 N■ 06 U 0 0224 N■ 06 U 0 0334	150,000 220,000 330,000	U	4840 (2)	- 5.3

■ = D for general purpose

■ = V for professional

Resistance - Temperature characteristics: pages 30 to 32.

HOW TO ORDER

ND06



Type

P0



Material Code
P
(See table above)

0103



Resistance
10 kΩ

K --



Tolerance
K (±10%)

Disc Thermistors NTC

General Purpose: ND 09
Professional: NV 09



Temperature compensation, temperature measurement, liquid level detection; these thermistors can be applied to most applications.

Types	GENERAL PURPOSE	PROFESSIONAL
	ND 09	NV 09
Finish	Coated disc with phenolic resin	Varnished disc
Standards		Approved by NFC 93 271 Type: TN 116 List: GAM-T1 List: LNZ
DIMENSIONS: millimeters (inches)		
Marking	Nominal resistance Tolerance for $\pm 5\%$, $\pm 10\%$	Nominal resistance Tolerance
Climatic category	–	55/125/56 - 434
Operating temperature	-55°C to +150°C	-55°C to +150°C
Tolerance on Rn (25°C)	$\pm 5\%$, $\pm 10\%$, $\pm 20\%$	$\pm 2\%$, $\pm 5\%$, $\pm 10\%$
Maximum dissipation at 25°C	0.9 W	0.85 W
Thermal dissipation factor	9 mW/°C	8.5 mW/°C
Thermal time constant	30 s	30 s

Table of Values



ND 09 - NV 09

Types	Rn at 25°C ()	Material Code	B (K) ($\frac{\Delta B}{B}$ ^{(1) ± 5%} _{(2) ± 3%})	α at 25°C (%/°C)
N■ 09 J 0 0680 N■ 09 J 0 0101	68 100	J	3480 (1)	- 3.9
N■ 09 K 0 0151 N■ 09 K 0 0221	150 220	K	3630 (1)	- 4.0
N■ 09 L 0 0331	330	L	3790 (2)	- 4.2
N■ 09 M 0 0471 N■ 09 M 0 0681	470 680	M	3950 (2)	- 4.4
N■ 09 N 0 0102 N■ 09 N 0 0152	1,000 1,500	N	4080 (2)	- 4.6
N■ 09 P 0 0222 N■ 09 P 0 0332	2,200 3,300	P	4220 (2)	- 4.7
N■ 09 Q 0 0472 N■ 09 Q 0 0682	4,700 6,800	Q	4300 (2)	- 4.7
N■ 09 R 0 0103 N■ 09 R 0 0153	10,000 15,000	R	4400 (2)	- 4.8
N■ 09 S 0 0223	22,000	S	4520 (2)	- 5.0
N■ 09 T 0 0333 N■ 09 T 0 0473	33,000 47,000	T	4630 (2)	- 5.1
N■ 09 U 0 0683 N■ 09 U 0 0104 N■ 09 U 0 0154	68,000 100,000 150,000	U	4840 (2)	- 5.3

■ = D for general purpose

■ = V for professional

Resistance - Temperature characteristics: pages 30 to 32.

HOW TO ORDER

ND09



Type

R0



Material Code
R
(See table above)

0103



Resistance
10 k Ω

K --



Tolerance
K ($\pm 10\%$)

This type of product is widely used in automotive and consumer applications.

They are assembled in custom-probes for sensing the temperature of liquids (water, oil, ...), gases or surface of any other component.

The metallization covers completely the surfaces of the thermistor.

The particularly flat and smooth surfaces ensure an excellent electrical and thermal contact under pressure.

Types	NR
Physical data (dim. in mm)	
Marking	On package only / On parts upon request
Operating temperature	-40°C to +200°C
Values and tolerances	Custom - designed products defined with: $D \pm \Delta D$ $R_1 \pm \Delta R_1 / R_1$ at T_1 $E \pm \Delta E$ $R_2 \pm \Delta R_2 / R_2$ at T_2, \dots

DESIGN OF THE THERMISTOR

Choice of the resistances

If the application is to measure the temperature around a defined point, a unique nominal resistance can be chosen (for example, among standard values of the ND range products presented on pages 16 to 21).

When it is required to measure the temperature over selected ranges $T_1 - T_2$, $T_2 - T_3$, ..., the corresponding resistance R_1 , R_2 , R_3 , ..., must be such that they can be located on the $R(T)$ characteristic of an existing NTC material (for example among standard materials whose $R(T)$ are displayed on pages 30 to 33).

The resistances must also be compatible with the resistivity of the material and the dimensions of the thermistor.

Choice of the tolerances

The precision of the temperature measurement determines the calculation of the tolerance on the resistance:

$$\Delta R/R = \alpha (\%/^{\circ}\text{C}) \cdot \Delta T (^{\circ}\text{C})$$

For example, the NTC NR55--3049-99, using "XD" material ($R(T)$ characteristic displayed on page 32), requires a precision of 1°C over the temperature range 110°C - 120°C.

The tolerances can be calculated:

$$\Delta R_{110^{\circ}\text{C}} / R_{110^{\circ}\text{C}} = 1^{\circ}\text{C} \cdot 2.91\%/^{\circ}\text{C} = 2.91\%$$

$$\Delta R_{120^{\circ}\text{C}} / R_{120^{\circ}\text{C}} = 1^{\circ}\text{C} \cdot 2.76\%/^{\circ}\text{C} = 2.76\%$$

*For your specific requirements, please consult us.

HOW TO ORDER

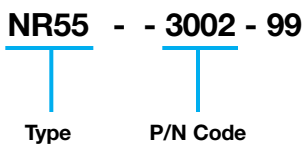

Leadless Disc Thermistors NTC



We present below some examples of our custom - designed products as an illustration of the different ways to define products.

DIMENSIONS: millimeters (inches)

Types	D	E	Material Code	B (k)	$R_1 \pm \Delta R_1$ at T_1	T_1 (°C)	$R_2 \pm \Delta R_2$ at T_2	T_2 (°C)	$R_3 \pm \Delta R_3$ at T_3	T_3 (°C)
NR 55 -- 3002 - 99	5.5 (.217) ± 0.5 (.020)	1.1 (.043) ± 0.4 (.016)	XD	4160	1230 Ω ± 7.5%	40	160 Ω ± 5%	96.5	-	-
NR 67 -- 3068 - 99	6.7 (.264) ± 0.5 (.020)	1.7 (.067) ± 0.3 (.012)	N	4080	150 Ω ± 3.3%	100	51 Ω ± 5.3%	140	-	-
NR 55 -- 3049 - 99	5.5 (.217) ± 0.5 (.020)	1.0 (.040) ± 0.2 (.008)	XD	4160	107 Ω ± 2.9%	110	80.6 Ω ± 2.8%	120	-	-
NR 55 -- 3046 - 99	5.5 (.217) ± 0.5 (.020)	1.3 (.051) ± 0.4 (.016)	S	4520	48600 Ω ± 7.5%	25	3210 Ω ± 5%	90	-	-
NR 49 -- 3119 - 99	4.9 (.193) ± 0.3 (.012)	1.5 (.060) ± 0.4 (.016)	M	3950	840 Ω ± 10%	37.8	84 Ω ± 5%	104.4	-	-
NR 55 -- 3114 - 99	5.5 (.217) ± 0.4 (.016)	1.0 (.040) ± 0.2 (.008)	P	4220	5000 Ω ± 10%	25	-	-	-	-
NR 70 -- 3121 - 99	7.0 (.275) ± 0.3 (.012)	1.2 (.047) ± 0.2 (.008)	L	3790	210 Ω ± 10%	40	40 Ω ± 7.5%	90	30 Ω ± 6.7%	100
NR 29 -- 3107 - 99	2.9 (.014) ± 0.3 (.012)	1.5 (.060) ± 0.3 (.012)	K	3630	2050 Ω ± 6%	25	193 Ω ± 5.4%	96.5	-	-
NR 55 -- 3122 - 99	5.5 (.217) ± 0.5 (.020)	1.5 (.060) ± 0.4 (.016)	J	3480	210 Ω ± 5%	25	-	-	-	-
NR 55 -- 3126 - 99	5.5 (.217) ± 0.5 (.020)	1.0 (.040) ± 0.2 (.008)	P	4220	3340 Ω ± 10%	25	264 Ω ± 7%	90	107 Ω ± 7%	120
NR 47 -- 3116 - 99	4.7 (.185) ± 0.4 (.016)	1.2 (.047) ± 0.2 (.008)	R	4400	33000 Ω ± 2%	25	-	-	-	-
NR 49 -- 3113 - 99	4.9 (.193) ± 0.3 (.012)	1.2 (.047) ± 0.2 (.008)	N	4080	1680 Ω ± 10%	40	382 Ω ± 6.7%	80	176 Ω ± 5%	105
NR 47 -- 3101 - 99	4.6 (.181) ± 0.3 (.012)	1.4 (.055) ± 0.3 (.012)	J	3480	146 Ω ± 13%	40	22 Ω ± 10%	100	-	-
NR 55 -- 3071 - 99	5.8 (.228) ± 0.3 (.012)	1.0 (.040) ± 0.2 (.008)	L	3790	262 Ω ± 8.7%	40	120 Ω ± 10%	60	35.5 Ω ± 7.8%	100
NR 61 -- 3063 - 99	6.1 (.240) ± 0.3 (.012)	1.5 (.060) ± 0.3 (.012)	N	4080	760 Ω ± 9.2%	50	130 Ω ± 8.5%	100	56.6 Ω ± 8.5%	130
NR 67 -- 3053 - 99	6.7 (.264) ± 0.4 (.016)	1.7 (.067) ± 0.3 (.012)	N	4080	540 Ω ± 11%	60	144 Ω ± 7%	100	-	-
NR 50 -- 3048 - 99	5.0 (.197) ± 0.5 (.020)	1.5 (.060) ± 0.5 (.020)	J	3480	233 Ω ± 10%	25	13.3 Ω ± 7%	121	-	-
NR 60 -- 3021 - 99	6.0 (.236) ± 0.5 (.020)	3.2 (.125) ± 0.3 (.012)	P	4220	3640 Ω ± 3%	40	457 Ω ± 3%	96.5	-	-
NR 55 -- 3016 - 99	5.5 (.217) ± 0.5 (.020)	1.1 (.043) ± 0.4 (.016)	Q	4300	5500 Ω ± 9%	40	650 Ω ± 7.7%	96.5	-	-

Resistance - Temperature characteristics: pages 30 to 32.

Thermistors NTC Insulated Metal Case NM 06



Especially designed for mounting on a chassis or screwing on a plate, these thermistors provide an excellent thermal

contact and ensure a good accuracy of measurement and alarm control for different types of equipment.

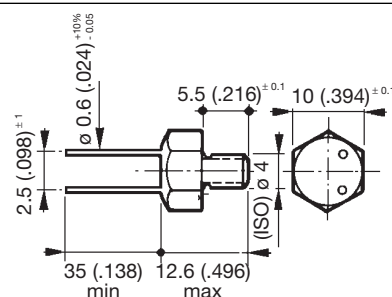
Type	NM 06
Finish	Disc thermistor, insulated metal case for chassis mounting
DIMENSIONS: millimeters (inches)	 <p>This type can be delivered with fixing nut, add suffix WC to the reference.</p>
Marking	Nominal resistance Tolerance for ±10%
Operating temperature	-55°C to +150°C
Table of values	See table on page 26
Tolerance on Rn (25°C)	±10% ±20%
Maximum dissipation at 25°C	0.8 W - without heat sink 2 W - with heat sink Part mounted in the center of a brass plate (dim.: 100 x 100 x 1 mm)
Thermal dissipation factor*	8 mW/°C: without heat sink 20 mW/°C: with heat sink
Thermal time constant	Depending on cooling system
Test voltage to earth	380 Vrms (50 Hz)

*Typical value

Table of Values



NM 06

Types	Rn at 25°C	Material Code	B (K) ($\Delta B/B$ (1) $\pm 5\%$ (2) $\pm 3\%$)	α at 25°C (%/°C)
NM 06 F 0 0100 NM 06 F 0 0150	10 15	F	2800 (1)	- 3.2
NM 06 G 0 0220 NM 06 G 0 0330	22 33	G	3030 (1)	- 3.4
NM 06 H 0 0470 NM 06 H 0 0680	47 68	H	3160 (1)	- 3.5
NM 06 I 0 0101	100	I	3340 (1)	- 3.7
NM 06 J 0 0151 NM 06 J 0 0221	150 220	J	3480 (1)	- 3.9
NM 06 K 0 0331 NM 06 K 0 0471	330 470	K	3630 (1)	- 4.0
NM 06 L 0 0681 NM 06 L 0 0102	680 1,000	L	3790 (2)	- 4.2
NM 06 M 0 0152	1,500	M	3950 (2)	- 4.4
NM 06 N 0 0222 NM 06 N 0 0332	2,200 3,300	N	4080 (2)	- 4.6
NM 06 P 0 0472 NM 06 P 0 0682 NM 06 P 0 0103	4,700 6,800 10,000	P	4220 (2)	- 4.7
NM 06 Q 0 0153 NM 06 Q 0 0223	15,000 22,000	Q	4300 (2)	- 4.7
NM 06 R 0 0333	33,000	R	4400 (2)	- 4.8
NM 06 S 0 0473 NM 06 S 0 0683	47,000 68,000	S	4520 (2)	- 5.0
NM 06 T 0 0104	100,000	T	4630 (2)	- 5.1
NM 06 U 0 0154 NM 06 U 0 0224 NM 06 U 0 0334	150,000 220,000 330,000	U	4840 (2)	- 5.3

Resistance - Temperature characteristics: pages 30 to 32.

HOW TO ORDER

NM06

Type

P0

Material Code
P
(See table above)

0103

Resistance
10 k Ω

M --

Tolerance
M ($\pm 20\%$)

Inrush Current Limiters Thermistors NTC



NF 08 - 10 - 13 - 15 - 20

(For more details see also the catalog dedicated to this range)

OUTLINE DRAWINGS

millimeters (inches)

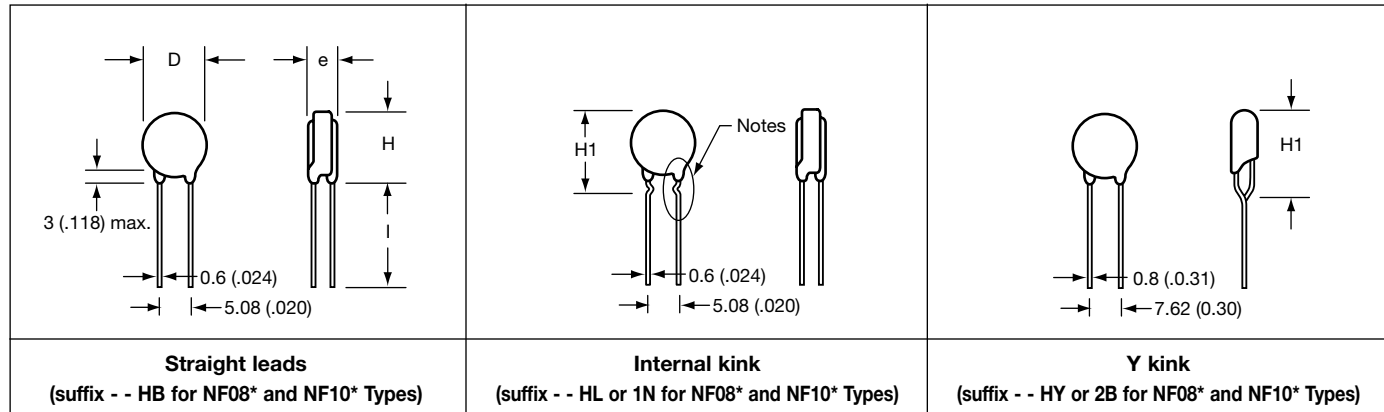

Notes: In case of adding strength to the lead wire from the side, it may occur crack and fragment at a part of pant leg.
* 0.6 mm copper wire and 5.08 mm leads spacing for those two types.

DIMENSIONS millimeters (inches)

Type	D max mm	e max mm	H max mm	H1 max mm	l min mm	d ±0.02 mm	E ±0.8 mm
NF08*	9.5 (.374)	5.0 (.197)	13.0 (.512)	16.0 (.630)	30 (1.181)	0.6 (.024)	5.08 (.20)
NF08	9.5 (.374)	5.0 (.197)	13.0 (.512)	16.0 (.630)	30 (1.181)	0.8 (.031)	7.62 (.03)
NF10*	11.5 (.453)	5.0 (.197)	15.0 (.591)	18.0 (.709)	30 (1.181)	0.6 (.024)	5.08 (.20)
NF10	11.5 (.453)	5.0 (.197)	15.0 (.591)	18.0 (.709)	30 (1.181)	0.8 (.031)	7.62 (.30)
NF13	15.0 (.591)	6.0 (.236)	18.0 (.709)	22.0 (.866)	30 (1.181)	0.8 (.031)	7.62 (.30)
NF15	17.0 (.669)	6.0 (.236)	20.0 (.787)	24.0 (.945)	30 (1.181)	1.0 (.039)	7.62 (.30)
NF20	22.0 (.866)	6.0 (.236)	25.0 (.984)	29.0 (1.142)	30 (1.181)	1.0 (.039)	7.62 (.30)

GENERAL CHARACTERISTICS

Type	Standard tolerance** %	Maximum operating T°C	Max power 25°C Watts	Thermal dissipation δ_{th} (mW/K)	Thermal time constant τ_c (s)	Heat capacity H (mJ/K)	Packing bulk	Packing tape
NF08*	20	-40 / +200	1.6	8	60	480	√	√
NF08	20	-40 / +200	2.2	11	60	660	√	√
NF10*	20	-40 / +200	2.0	10	75	750	√	-
NF10	20	-40 / +200	2.6	13	75	975	√	√
NF13	20	-40 / +200	3.2	16	100	1600	√	√
NF15	20	-40 / +200	4.1	20	115	2300	√	-
NF20	20	-40 / +200	5.0	25	160	4000	√	-

* 0.6 mm copper wire and 5.08 mm leads spacing for those two types.
** Other tolerances available: L: ±15, X: ±25%

HOW TO ORDER

NF13



Type

AA



Inrush
Current
Limiters

0509



Resistance
5 kΩ

M



Tolerance
M (±20%)

--



Suffix
Bulk, Straight Leads
(See illustration above)

Table of Values



NF 08 - 10 - 13 - 15 - 20

cUL	Ceramic Disc ø (mm)	Part number reference T _{pe}	Zero power resistance R _{25°C} (Ω)	Max steady state current I _{ss} max 25°C (A)	Resistance at max current R _{iss} max (Ω)
*	08	NF08AA0509MHB	5.0	2.9	0.20
*		NF08AA0809MHB	8.0	2.3	0.30
*		NF08AA0100MHB	10.0	2.1	0.37
*		NF08AA0150MHB	15.0	1.8	0.50
*		NF08AA0330MHB	33.0	1.3	0.97
*	08	NF08AA0509M --	5.0	3.4	0.20
*		NF08AA0809M --	8.0	2.7	0.30
*		NF08AA0100M --	10.0	2.5	0.37
*		NF08AA0150M --	15.0	2.1	0.50
*		NF08AA0330M --	33.0	1.5	0.97
*	10	NF10AA0259MHB	2.5	4.5	0.10
*		NF10AA0409MHB	4.0	3.6	0.16
*		NF10AA0509MHB	5.0	3.3	0.19
*		NF10AA0809MHB	8.0	2.6	0.30
*		NF10AA0100MHB	10.0	2.5	0.34
*		NF10AA0160MHB	16.0	2.0	0.50
*		NF10AA0200MHB	20.0	1.9	0.59
*		NF10AA0250MHB	25.0	1.7	0.69
*		NF10AA0500MHB	50.0	1.4	1.07
*		NF10AA0800MHB	80.0	1.1	1.60
*		NF10AA0121MHB	120.0	1.0	1.90
*		10	NF10AA0259M --	2.5	5.2
*	NF10AA0409M --		4.0	4.1	0.16
*	NF10AA0509M --		5.0	3.8	0.19
*	NF10AA0809M --		8.0	3.0	0.30
*	NF10AA0100M --		10.0	2.8	0.34
*	NF10AA0160M --		16.0	2.3	0.50
*	NF10AA0200M --		20.0	2.1	0.59
*	NF10AA0250M --		25.0	2.0	0.69
*	NF10AA0500M --		50.0	1.6	1.07
*	NF10AA0800M --		80.0	1.3	1.60
*	NF10AA0121M --		120.0	1.2	1.90
*	13		NF13AA0259M --	2.5	5.7
*		NF13AA0509M --	5.0	4.2	0.19
*		NF13AA0709M --	7.0	3.7	0.24
*		NF13AA0809M --	8.0	3.6	0.25
*		NF13AA0100M --	10.0	3.3	0.30
*		NF13AA0150M --	15.0	2.8	0.41
*		NF13AA0220M --	22.0	2.3	0.61
*		NF13AA0330M --	33.0	2.2	0.70
*		NF13AA0400M --	40.0	2.0	0.80
*		NF13AA0600M --	60.0	1.9	0.95
*		15	NF15AA0139M --	1.3	8.9
*	NF15AA0159M --		1.5	8.3	0.06
*	NF15AA0259M --		2.5	6.6	0.09
*	NF15AA0309M --		3.0	6.1	0.11
*	NF15AA0409M --		4.0	5.5	0.13
*	NF15AA0509M --		5.0	4.9	0.17
*	NF15AA0609M --		6.0	4.7	0.19
*	NF15AA0709M --		7.0	4.3	0.22
*	NF15AA0809M --		8.0	4.2	0.24
*	NF15AA0100M --		10.0	3.7	0.30
*	NF15AA0120M --		12.0	3.5	0.33
*	NF15AA0160M --		16.0	3.0	0.44
*	NF15AA0200M --		20.0	3.1	0.43
*	NF15AA0250M --		25.0	2.8	0.53
*	NF15AA0330M --		33.0	2.5	0.66
*	NF15AA0400M --	40.0	2.3	0.80	
*	NF15AA0470M --	47.0	2.3	0.74	
*	20	NF20AA0109M --	1.0	11.4	0.04
*		NF20AA0259M --	2.5	7.8	0.08
*		NF20AA0409M --	4.0	6.4	0.13
*		NF20AA0509M --	5.0	5.9	0.15
*		NF20AA0100M --	10.0	4.3	0.28
*		NF20AA0150M --	15.0	4.0	0.32
*		NF20AA0330M --	33.0	3.1	0.52

* cL/L approval (File E167822)

- Electrical performances for suffixes HL and HY are identical to the suffix --.
- Electrical performances for suffixes 1N and 2B are identical to the suffix HB

Ring Thermistors NTC



NA 19 - NL 19 - NA 57 - NL 57

The large size of these thermistors has been designed to meet heavy-duty requirements in surge protection and current limitation.

Our product development department will provide you with full technical assistance to meet your special requirements.

Type	NA 19 NA 57	NA 19 NL 57	
Finish	Metallized leadless		
DIMENSIONS: millimeters (inches)	NA 19 	NL 19 	
	NA 57 	NL 57 	
	Marking	Nominal resistance Tolerance	
	Operating temperature	-25°C to +200°C	
Table of values	See table on page 32		
Tolerance on Rn (25°C)	±10% ±20%		
Maximum dissipation at 25°C	NA 19: 5.25 W	NA 57: 17.5 W	
Thermal dissipation factor	NA 19: 30 mW/°C	NA 57: 100 mW/°C	
Thermal time constant	NA 19: 300 s	NA 57: 900 s	
	Depending on mounting		

HOW TO ORDER

NA57

Type

J0

Material Code

J
(See table page 29)

0100

Resistance
10 kΩ

M --

Tolerance
M (±20%)

Table of Values



NA 19 - NL 19 - NA 57 - NL 57

Types	Rn at 25°C	Material Code	B (K) ($\Delta B/B$ (1) $\pm 5\%$ (2) $\pm 3\%$)	α at 25°C (%/°C)	I max.* (A)
N■ 19 F 0 0339	3.3	F	2800 (1)	- 3.2	6.5
N■ 19 G 0 0479	4.7	G	3030 (1)	- 3.4	6.0
N■ 19 G 0 0689	6.8				5.6
N■ 19 H 0 0100	10	H	3160 (1)	- 3.5	4.8
N■ 19 H 0 0150	15				4.2
N■ 19 I 0 0220	22	I	3340 (1)	- 3.7	3.4
N■ 19 I 0 0330	33				3.1
N■ 19 J 0 0470	47	J	3480 (1)	- 3.9	2.6
N■ 19 J 0 0680	68				2.3
N■ 19 K 0 0101	100	K	3630 (1)	- 4.0	2.1
N■ 19 K 0 0151	150				1.9
N■ 19 L 0 0221	220	L	3790 (2)	- 4.2	1.7
N■ 19 M 0 0331	330	M	3950 (2)	- 4.4	1.5
N■ 19 M 0 0471	470				1.2
N■ 19 N 0 0681	680	N	4080 (2)	- 4.6	1.1
N■ 19 N 0 0102	1,000				1.0

* For type: NL 19

Types	Rn at 25°C	Material Code	B (K) ($\Delta B/B \pm 5\%$)	α at 25°C (%/°C)	I max.* (A)
N■ 57 I 0 0339	3.3	I	3340 (1)	3.7	20
N■ 57 I 0 0479	4.7				17
N■ 57 J 0 0689	6.8	J	3480 (1)	3.9	14.5
N■ 57 J 0 0100	10.0				11.5
N■ 57 K 0 0150	15.0	K	3630 (1)	4.0	9.0

* For type: NL 57

■ = A or L

Resistance - Temperature characteristics: pages 30 to 32.

VOLTAGE - CURRENT CHARACTERISTICS

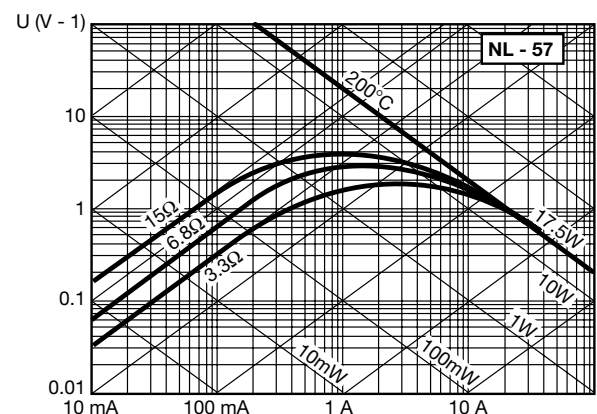
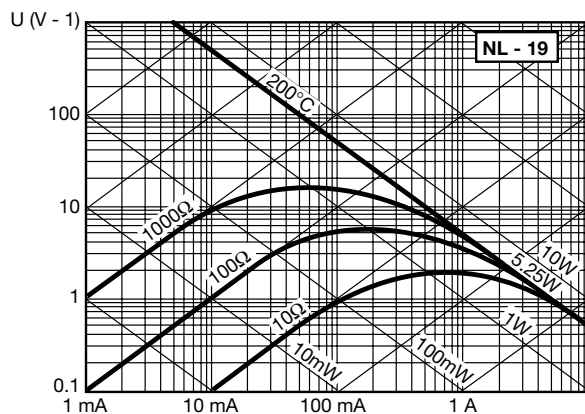

Resistance



Temperature Characteristics

T (°C)	Material code B (K)									T (°C)
	F 2800			G 3030			H 3160			
	R (T) / R25	TF (%)	α (%/°C)	R (T) / R25	TF (%)	α (%/°C)	R (T) / R25	TF (%)	α (%/°C)	
-55	29.51	27.5	5.81	33.43	29.7	5.81	38.50	31.0	6.03	-55
-50	22.33	23.7	5.56	25.27	25.7	5.59	28.80	26.8	5.81	-50
-45	17.09	20.4	5.33	19.29	22.1	5.39	21.76	23.0	5.60	-45
-40	13.12	17.4	5.11	14.87	18.9	5.20	16.60	19.7	5.41	-40
-35	10.45	14.8	4.90	11.56	16.0	5.02	12.78	16.7	5.22	-35
-30	8.160	12.5	4.71	9.069	13.5	4.84	9.930	14.1	5.04	-30
-25	6.499	10.4	4.52	7.171	11.3	4.68	7.779	11.8	4.87	-25
-20	5.221	8.6	4.35	5.715	9.3	4.52	6.143	9.7	4.70	-20
-15	4.228	7.0	4.19	4.589	7.6	4.37	4.889	7.9	4.55	-15
-10	3.450	5.6	4.03	3.711	6.1	4.22	3.919	6.3	4.40	-10
-5	2.836	4.4	3.89	3.021	4.7	4.09	3.164	4.9	4.26	-5
0	2.348	3.3	3.75	2.476	3.6	3.96	2.572	3.7	4.12	0
5	1.956	2.4	3.62	2.042	2.6	3.83	2.104	2.7	3.99	5
10	1.640	1.6	3.49	1.694	1.8	3.71	1.732	1.8	3.87	10
15	1.383	1.0	3.38	1.413	1.1	3.60	1.434	1.1	3.75	15
20	1.173	.4	3.26	1.186	.5	3.49	1.194	.5	3.63	20
25	1.0000	0.0	3.16	1.0000	0.0	3.38	1.0000	0.0	3.53	25
30	.8570	.4	3.06	.8476	.5	3.28	.8417	.5	3.42	30
35	.7381	.9	2.96	.7220	1.0	3.18	.7121	1.0	3.32	35
40	.6386	1.4	2.87	.6178	1.6	3.09	.6053	1.6	3.22	40
45	.5550	2.0	2.78	.5310	2.2	3.00	.5169	2.3	3.13	45
50	.4844	2.7	2.69	.4584	2.9	2.92	.4434	3.0	3.04	50
55	.4245	3.3	2.61	.3973	3.6	2.83	.3820	3.7	2.96	55
60	.3734	4.0	2.54	.3458	4.3	2.76	.3305	4.5	2.87	60
65	.3297	4.7	2.46	.3021	5.1	2.68	.2870	5.3	2.80	65
70	.2922	5.5	2.39	.2648	5.9	2.61	.2502	6.2	2.72	70
75	.2598	6.3	2.33	.2330	6.8	2.54	.2189	7.1	2.65	75
80	.2318	7.1	2.26	.2057	7.6	2.47	.1923	8.0	2.58	80
85	.2074	7.9	2.20	.1822	8.5	2.40	.1694	8.9	2.51	85
90	.1861	8.7	2.14	.1619	9.4	2.34	.1498	9.8	2.44	90
95	.1676	9.5	2.08	.1443	10.3	2.38	.1328	10.8	2.38	95
100	.1513	10.4	2.03	.1290	11.2	2.22	.1181	11.7	2.32	100
105	.1369	11.2	1.97	.1156	12.2	2.17	.1054	12.7	2.26	105
110	.1242	12.1	1.92	.1039	13.1	2.11	.09430	13.7	2.21	110
115	.1130	13.0	1.87	.09365	14.0	2.06	.08460	14.6	2.15	115
120	.1030	13.9	1.83	.08461	15.0	2.01	.07610	15.6	2.10	120
125	.09417	14.7	1.78	.07663	15.9	1.96	.06863	16.6	2.05	125
130	.08625	15.6	1.74	.06957	16.9	1.92	.06204	17.6	2.00	130
135	.07917	16.5	1.70	.06330	17.9	1.87	.05623	18.6	1.95	135
140	.07282	17.4	1.66	.05772	18.8	1.83	.05107	19.6	1.91	140
145	.06711	18.3	1.62	.05275	19.8	1.78	.04649	20.6	1.86	145
150	.06197	19.2	1.58	.04831	20.7	1.74	.04242	21.6	1.82	150

T (°C)	Material code B (K)									T (°C)
	I 3340			J 3480			K 3630			
	R (T) / R25	TF (%)	α (%/°C)	R (T) / R25	TF (%)	α (%/°C)	R (T) / R25	TF (%)	α (%/°C)	
-55	42.62	32.7	6.33	51.74	34.1	6.43	56.26	35.6	6.46	-55
-50	34.38	28.3	6.11	37.97	29.5	6.21	41.21	30.8	6.26	-50
-45	25.62	24.3	5.89	28.15	25.3	6.01	30.47	26.4	6.06	-45
-40	19.29	20.8	5.69	21.07	21.7	5.81	22.73	22.6	5.88	-40
-35	14.66	17.7	5.49	15.91	18.4	5.62	17.11	19.2	5.70	-35
-30	11.24	14.9	5.30	12.13	15.5	5.44	12.98	16.2	5.53	-30
-25	8.694	12.4	5.13	9.320	12.9	5.26	9.930	13.5	5.36	-25
-20	6.782	10.3	4.96	7.221	10.7	5.10	7.654	11.2	5.21	-20
-15	5.332	8.4	4.80	5.640	8.7	4.94	5.945	9.1	5.05	-15
-10	4.224	6.7	4.64	4.438	7.0	4.78	4.650	7.3	4.91	-10
-5	3.372	5.2	4.49	3.517	5.4	4.64	3.663	5.7	4.76	-5
0	2.710	4.0	4.35	2.807	4.1	4.50	2.905	4.3	4.63	0
5	2.193	2.9	4.21	2.255	3.0	4.36	2.319	3.1	4.50	5
10	1.786	2.0	4.08	1.824	2.0	4.23	1.862	2.1	4.37	10
15	1.463	1.2	3.96	1.484	1.2	4.10	1.505	1.3	4.25	15
20	1.206	.5	3.84	1.215	.5	3.98	1.223	.6	4.13	20
25	1.0000	0.0	3.73	1.0000	0.0	3.87	1.0000	0.0	4.01	25
30	.8336	.5	3.62	.8278	.5	3.76	.8219	.6	3.90	30
35	.6956	1.1	3.51	.6889	1.1	3.65	.6792	1.2	3.80	35
40	.5884	1.7	3.41	.5763	1.8	3.55	.5641	1.9	3.69	40
45	.4980	2.4	3.31	.4845	2.5	3.45	.4708	2.6	3.59	45
50	.4235	3.2	3.22	.4092	3.3	3.35	.3949	3.4	3.50	50
55	.3617	4.0	3.13	.3473	4.1	3.26	.3327	4.3	3.41	55
60	.3103	4.8	3.04	.2960	5.0	3.17	.2816	5.2	3.32	60
65	.2673	5.7	2.96	.2534	5.9	3.09	.2393	6.1	3.23	65
70	.2312	6.5	2.88	.2178	6.8	3.01	.2043	7.1	3.14	70
75	.2008	7.5	2.80	.1879	7.8	2.93	.1751	8.1	3.06	75
80	.1750	8.4	2.73	.1628	8.8	2.85	.1507	9.1	2.99	80
85	.1531	9.4	2.66	.1415	9.8	2.78	.1301	10.2	2.91	85
90	.1344	10.4	2.59	.1235	10.8	2.70	.1128	11.3	2.84	90
95	.1183	11.4	2.52	.1081	11.8	2.64	.09812	12.4	2.77	95
100	.1045	12.4	2.46	.09500	12.9	2.57	.08565	13.5	2.70	100
105	.09266	13.4	2.39	.08373	14.0	2.50	.07502	14.6	2.63	105
110	.08237	14.4	2.33	.07403	15.0	2.44	.06592	15.7	2.57	110
115	.07344	15.5	2.28	.06565	16.1	2.38	.05810	16.8	2.50	115
120	.06565	16.5	2.22	.05838	17.2	2.33	.05137	18.0	2.44	120
125	.05886	17.6	2.17	.05207	18.3	2.27	.04555	19.1	2.39	125
130	.05290	18.6	2.12	.04567	19.4	2.22	.04050	20.3	2.33	130
135	.04767	19.7	2.07	.04175	20.5	2.16	.03611	21.4	2.27	135
140	.04306	20.7	2.02	.03753	21.6	2.11	.03229	22.5	2.22	140
145	.03898	21.8	1.97	.03382	22.7	2.06	.02894	23.7	2.17	145
150	.03538	22.9	1.92	.03055	23.8	2.02	.02600	24.9	2.12	150

Resistance



Temperature Characteristics

T (°C)	Material code B (K)									T (°C)
	L 3790			M 3950			N 4080			
	R (T) / R25	TF (%)	α (%/°C)	R (T) / R25	TF (%)	α (%/°C)	R (T) / R25	TF (%)	α (%/°C)	
-55	82.52	22.3	7.38	99.56	23.2	7.71	110.1	24.0	7.81	-55
-50	58.01	19.3	7.11	68.95	20.1	7.42	75.90	20.7	7.53	-50
-45	41.30	16.6	6.84	48.38	17.3	7.15	52.98	17.8	7.26	-45
-40	29.75	14.2	6.60	34.37	14.8	6.89	37.43	15.2	7.01	-40
-35	21.67	12.0	6.36	24.71	12.5	6.64	26.75	12.9	6.77	-35
-30	15.96	10.1	6.13	17.96	10.6	6.41	19.33	10.9	6.54	-30
-25	11.88	8.5	5.92	13.20	8.8	6.18	14.12	9.1	6.32	-25
-20	8.930	7.0	5.72	9.803	7.3	5.97	10.41	7.5	6.10	-20
-15	6.776	5.7	5.32	7.351	5.9	5.77	7.758	6.1	5.90	-15
-10	5.188	4.5	5.34	5.585	4.7	5.57	5.834	4.9	5.71	-10
-5	4.007	3.6	5.16	4.251	3.7	5.39	4.426	3.8	5.53	-5
0	3.120	2.7	4.99	3.275	2.8	5.21	3.387	2.9	5.35	0
5	2.449	2.0	4.83	2.544	2.0	5.04	2.614	2.1	5.18	5
10	1.937	1.3	4.68	1.992	1.4	4.88	2.033	1.4	5.02	10
15	1.543	.8	4.53	1.572	.8	4.73	1.593	.9	4.87	15
20	1.238	.4	4.39	1.249	.4	4.58	1.258	.4	4.72	20
25	1.0000	0.0	4.25	1.0000	0.0	4.44	1.0000	0.0	4.57	25
30	.8129	.3	4.12	.8057	.4	4.30	.8004	.4	4.44	30
35	.6648	.7	4.00	.6534	.8	4.17	.6448	.8	4.31	35
40	.5409	1.2	3.88	.5331	1.2	4.05	.5228	1.3	4.18	40
45	.4525	1.6	3.77	.4376	1.7	3.93	.4264	1.8	4.06	45
50	.3765	2.2	3.66	.3612	2.2	3.81	.3497	2.3	3.94	50
55	.3148	2.7	3.55	.2998	2.8	3.71	.2885	2.9	3.83	55
60	.2646	3.3	3.45	.2501	3.4	3.60	.2392	3.5	3.72	60
65	.2235	3.8	3.36	.2097	4.0	3.50	.1994	4.1	3.62	65
70	.1896	4.5	3.26	.1767	4.6	3.40	.1671	4.8	3.52	70
75	.1616	5.1	3.17	.1496	5.3	3.31	.1406	5.5	3.42	75
80	.1383	5.7	3.09	.1272	6.0	3.22	.1189	6.2	3.33	80
85	.1189	6.4	3.00	.1087	6.7	3.13	.1010	6.9	3.24	85
90	.1026	7.1	2.92	.09321	7.4	3.05	.08617	7.6	3.16	90
95	.08889	7.7	2.85	.08027	8.1	2.97	.07381	8.3	3.07	95
100	.07729	8.4	2.77	.06939	8.8	2.89	.06347	9.1	2.99	100
105	.06745	9.1	2.70	.06020	9.5	2.82	.05480	9.8	2.92	105
110	.05906	9.8	2.63	.05243	10.2	2.75	.04148	10.6	2.84	110
115	.05189	10.5	2.57	.04581	11.0	2.68	.04129	11.3	2.77	115
120	.04573	11.3	2.50	.04017	11.7	2.61	.03603	12.1	2.70	120
125	.04043	12.0	2.44	.03533	12.5	2.55	.03155	12.9	2.64	125
130	.03585	12.7	2.38	.03117	13.2	2.48	.02771	13.7	2.57	130
135	.03188	13.4	2.33	.02759	14.0	2.42	.02442	14.4	2.51	135
140	.02843	14.1	2.27	.02449	14.7	2.37	.02158	15.2	2.45	140
145	.02543	14.8	2.22	.02180	15.5	2.31	.01913	16.0	2.39	145
150	.02279	15.6	2.17	.01945	16.2	2.26	.01700	16.8	2.34	150

T (°C)	Material code B (K)									T (°C)
	P 4220			Q 4300			R 4400			
	R (T) / R25	TF (%)	α (%/°C)	R (T) / R25	TF (%)	α (%/°C)	R (T) / R25	TF (%)	α (%/°C)	
-55	121.3	24.8	7.88	98.02	25.5	7.14	113.9	25.9	7.42	-55
-50	83.32	21.4	7.61	69.51	22.0	6.95	79.69	22.4	7.22	-50
-45	57.91	18.4	7.36	49.72	18.9	6.77	56.29	19.2	7.03	-45
-40	40.71	15.8	7.11	35.86	16.2	6.59	40.12	16.4	6.84	-40
-35	28.95	13.4	6.88	26.08	13.7	6.42	28.85	14.0	6.66	-35
-30	20.80	11.3	6.66	19.12	11.6	6.26	20.92	11.8	6.48	-30
-25	15.10	9.4	6.44	14.12	9.7	6.10	15.29	9.8	6.31	-25
-20	11.07	7.8	6.24	10.51	8.0	5.94	11.27	8.1	6.14	-20
-15	8.196	6.3	6.04	7.876	6.5	5.79	8.367	6.6	5.98	-15
-10	6.123	5.1	5.85	5.946	5.2	5.64	6.260	5.3	5.83	-10
-5	4.615	4.0	5.67	4.520	4.1	5.50	4.719	4.1	5.67	-5
0	3.507	3.0	5.49	3.460	3.1	5.36	3.583	3.1	5.53	0
5	2.688	2.2	5.33	2.666	2.2	5.23	2.739	2.3	5.38	5
10	2.078	1.5	5.16	2.067	1.5	5.09	2.108	1.5	5.24	10
15	1.616	.9	5.01	1.613	.9	4.96	1.634	.9	5.11	15
20	1.267	.4	4.86	1.266	.4	4.84	1.274	.4	4.97	20
25	1.0000	0.0	4.72	1.0000	0.0	4.72	1.0000	0.0	4.84	25
30	.7949	.4	4.58	.7944	.4	4.60	.7897	.4	4.72	30
35	.6360	.8	4.45	.6347	.8	4.48	.6273	.9	4.60	35
40	.5120	1.3	4.32	.5099	1.3	4.37	.5012	1.4	4.48	40
45	.4148	1.8	4.20	.4119	1.9	4.26	.4026	1.9	4.36	45
50	.3380	2.4	4.06	.3345	2.5	4.15	.3255	2.5	4.25	50
55	.2769	3.0	3.96	.2730	3.1	4.05	.2644	3.1	4.14	55
60	.2282	3.6	3.86	.2239	3.7	3.95	.2159	3.8	4.04	60
65	.1890	4.3	3.75	.1846	4.4	3.85	.1772	4.5	3.03	65
70	.1573	5.0	3.65	.1529	5.1	3.75	.1462	5.2	3.83	70
75	.1316	5.7	3.55	.1272	5.8	3.66	.1212	5.9	3.74	75
80	.1106	6.4	3.45	.1063	6.5	3.57	.1009	6.7	3.64	80
85	.09338	7.1	3.36	.08928	7.3	3.48	.08441	7.4	3.55	85
90	.07919	7.9	3.28	.07527	8.1	3.39	.07093	8.2	3.46	90
95	.06744	8.6	3.19	.06373	8.8	3.31	.05985	9.0	3.38	95
100	.05767	9.4	3.11	.05417	9.6	3.23	.05072	9.8	3.29	100
105	.04951	10.2	3.03	.04623	10.4	3.15	.04315	10.6	3.21	105
110	.04267	10.9	2.95	.03961	11.2	3.07	.03686	11.4	3.13	110
115	.03691	11.7	2.88	.03405	12.0	3.00	.03160	12.2	3.06	115
120	.03204	12.5	2.81	.02939	12.9	2.93	.02720	13.1	2.98	120
125	.02791	13.3	2.74	.02545	13.7	2.86	.02349	13.9	2.91	125
130	.02440	14.1	2.67	.02211	14.5	2.79	.02036	14.7	2.84	130
135	.02139	14.9	2.61	.01928	15.3	2.72	.01771	15.6	2.77	135
140	.01882	15.7	2.55	.01686	16.1	2.66	.01545	16.4	2.71	140
145	.01660	16.5	2.49	.01479	17.0	2.60	.01353	17.2	2.64	145
150	.01469	17.3	2.43	.01302	17.8	2.54	.01188	18.1	2.58	150

Resistance



Temperature Characteristics

T (°C)	Material code B (K)									T (°C)
	S 4520			T 4630			U 4840			
	R (T) / R25	TF (%)	α (%/°C)	R (T) / R25	TF (%)	α (%/°C)	R (T) / R25	TF (%)	α (%/°C)	
-55	126.1	26.6	7.55	137.0	27.2	7.64	173.7	28.5	8.04	-55
-50	87.73	23.0	7.35	94.92	23.5	7.45	118.2	24.6	7.83	-50
-45	61.59	19.8	7.16	66.34	20.2	7.26	81.16	21.2	7.63	-45
-40	43.62	16.9	6.97	46.77	17.3	7.09	56.25	18.1	7.44	-40
-35	31.17	14.3	6.79	33.25	14.7	6.90	39.33	15.4	7.25	-35
-30	22.45	12.1	6.62	23.83	12.4	6.72	27.74	12.9	7.07	-30
-25	16.31	10.1	6.45	17.22	10.3	6.56	19.73	10.8	6.89	-25
-20	11.94	8.3	6.28	12.54	8.5	6.39	14.15	8.9	6.71	-20
-15	8.808	6.8	6.12	9.205	6.9	6.23	10.23	7.3	6.54	-15
-10	6.548	5.4	5.96	6.806	5.6	6.08	7.456	5.8	6.38	-10
-5	4.904	4.2	5.81	5.069	4.3	5.92	5.475	4.5	6.22	-5
0	3.699	3.2	5.66	3.803	3.3	5.78	4.051	3.4	6.06	0
5	2.810	2.3	5.52	2.873	2.4	5.63	3.019	2.5	5.91	5
10	2.149	1.6	5.38	2.185	1.6	5.49	2.267	1.7	5.76	10
15	1.654	1.0	5.24	1.673	1.0	5.35	1.714	1.0	5.61	15
20	1.282	.4	5.10	1.289	.4	5.22	1.305	.5	5.47	20
25	1.0000	0.0	4.97	1.0000	0.0	5.09	1.0000	0.0	5.33	25
30	.7848	.4	4.85	.7805	.4	4.96	.7715	.4	5.20	30
35	.6196	.9	4.72	.6129	.9	4.83	.5991	.9	5.06	35
40	.4922	1.4	4.60	.4842	1.4	4.71	.4681	1.5	4.94	40
45	.3932	2.0	4.48	.3847	2.0	4.59	.3681	2.1	4.81	45
50	.3158	2.6	4.37	.3074	2.6	4.48	.2911	2.8	4.69	50
55	.2551	3.2	4.26	.2470	3.3	4.37	.2316	3.4	4.57	55
60	.2072	3.9	4.15	.1996	4.0	4.26	.1853	4.2	4.45	60
65	.1691	4.6	4.05	.1621	4.7	4.15	.1491	4.9	4.34	65
70	.1387	5.3	3.94	.1323	5.4	4.04	.1207	5.7	4.23	70
75	.1144	6.1	3.84	.1086	6.2	3.94	.09813	6.5	4.12	75
80	.09477	6.8	3.75	.08953	7.0	3.84	.08023	7.3	4.02	80
85	.07888	7.6	3.65	.07417	7.8	3.75	.06592	8.2	3.91	85
90	.06595	8.4	3.56	.06173	8.6	3.65	.05443	9.0	3.82	90
95	.05539	9.2	3.47	.05161	9.5	3.56	.04515	9.9	3.72	95
100	.04671	10.1	3.39	.04334	10.3	3.47	.03763	10.8	3.63	100
105	.03956	10.9	3.30	.03655	11.2	3.39	.03151	11.7	3.54	105
110	.03364	11.7	3.22	.03095	12.0	3.31	.02650	12.6	3.45	110
115	.02872	12.6	3.14	.02632	12.9	3.22	.02237	13.5	3.38	115
120	.02461	13.4	3.07	.02247	13.7	3.15	.01897	14.4	3.28	120
125	.02117	14.3	2.99	.01925	14.6	3.07	.01615	15.3	3.20	125
130	.01828	15.1	2.92	.01656	15.5	2.99	.01381	16.2	3.12	130
135	.01584	16.0	2.85	.01429	16.4	2.92	.01185	17.1	3.04	135
140	.01376	16.8	2.78	.01238	17.3	2.85	.01020	18.0	2.97	140
145	.01201	17.7	2.72	.01076	18.1	2.78	.00882	19.0	2.90	145
150	.01050	18.6	2.65	.00938	19.0	2.72	.00765	19.9	2.83	150

T (°C)	Material code B (K)									T (°C)
	KC 3470			MC 3910			XD			
	R (T) / R25	TF (%)	α (%/°C)	R (T) / R25	TF (%)	α (%/°C)	R (T) / R25	TF (%)	α (%/°C)	
-55	60.08	34.0	7.00	100.6	38.3	7.88	115.8	16.3	7.83	-55
-50	43.19	29.4	6.71	69.29	33.1	7.55	79.70	14.1	7.56	-50
-45	31.42	25.3	6.44	48.41	28.5	7.24	55.53	12.1	7.30	-45
-40	23.13	21.6	6.18	34.27	24.3	6.96	39.14	10.4	7.06	-40
-35	17.22	18.4	5.94	24.57	20.7	6.68	27.90	8.8	6.82	-35
-30	12.95	15.5	5.71	17.83	17.4	6.42	20.11	7.4	6.60	-30
-25	9.842	12.9	5.49	13.09	14.5	6.18	14.64	6.2	6.38	-25
-20	7.550	10.7	5.29	9.714	12.0	5.95	10.77	5.1	6.17	-20
-15	5.845	8.7	5.10	7.283	9.8	5.73	7.995	4.2	5.97	-15
-10	4.564	6.9	4.91	5.515	7.8	5.53	5.991	3.3	5.78	-10
-5	3.594	5.4	4.74	4.215	6.1	5.33	4.529	2.6	5.60	-5
0	2.853	4.1	4.58	3.251	4.6	5.15	3.453	2.0	5.43	0
5	2.281	3.0	4.42	2.528	3.4	4.97	2.655	1.4	5.26	5
10	1.838	2.0	4.27	1.983	2.3	4.80	2.057	1.0	5.10	10
15	1.491	1.2	4.13	1.567	1.4	4.65	1.606	.6	4.95	15
20	1.217	0.5	4.00	1.247	0.6	4.49	1.263	.3	4.80	20
25	1.0000	0.0	3.90	1.0000	0.0	4.40	1.0000	0.0	4.65	25
30	0.8267	0.5	3.74	0.8072	0.6	4.21	.7973	.3	4.52	30
35	0.6873	1.1	3.63	0.6558	1.3	4.08	.6398	.5	4.39	35
40	0.5747	1.8	3.52	0.5361	2.0	3.96	.5167	.9	4.26	40
45	0.4830	2.5	3.41	0.4409	2.8	3.84	.4198	1.2	4.14	45
50	0.4081	3.3	3.31	0.3647	3.7	3.72	.3430	1.6	4.02	50
55	0.3465	4.1	3.21	0.3033	4.6	3.61	.2819	2.0	3.91	55
60	0.2955	5.0	3.12	0.2535	5.6	3.51	.2329	2.4	3.80	60
65	0.2532	5.9	3.03	0.2130	6.6	3.41	.1934	2.8	3.69	65
70	0.2179	6.8	2.94	0.1798	7.7	3.31	.1615	3.3	3.59	70
75	0.1883	7.8	2.86	0.1525	8.7	3.22	.1354	3.7	3.50	75
80	0.1634	8.7	2.78	0.1299	9.9	3.13	.1141	4.2	3.40	80
85	0.1423	9.7	2.71	0.1112	11.0	3.05	.09660	4.7	3.31	85
90	0.12441	10.8	2.63	0.09551	12.1	2.97	.08212	5.2	3.23	90
95	0.10915	11.8	2.56	0.08238	13.3	2.89	.07011	5.7	3.14	95
100	0.09608	12.9	2.50	0.07132	14.5	2.81	.06010	6.2	3.06	100
105	0.08486	13.9	2.43	0.06198	15.7	2.74	.05172	6.7	2.98	105
110	0.07519	15.0	2.37	0.05405	16.9	2.67	.04467	7.2	2.91	110
115	0.06683	16.1	2.31	0.04730	18.1	2.60	.03873	7.7	2.83	115
120	0.05957	17.2	2.25	0.04153	19.3	2.54	.03370	8.2	2.76	120
125	0.05325	18.3	2.20	0.03657	20.6	2.48	.02942	8.8	2.70	125
130	0.04774	19.4	2.14	0.03231	21.8	2.42	.02576	9.3	2.63	130
135	0.04290	20.5	2.09	0.02863	23.0	2.36	.02264	9.8	2.57	135
140	0.03866	21.6	2.04	0.02544	24.3	2.30	.01995	10.3	2.51	140
145	0.03492	22.7	1.99	0.02267	25.5	2.25	.01764	10.9	2.45	145
150	0.03162	23.8	1.95	0.02025	26.8	2.20	.01564	11.4	2.39	150

Resistance



Temperature Characteristics

T (°C)	Material code B (K)									T (°C)
	KA 3625			MA 3960			NA 4100			
	R (T) / R25	TF (%)	α (%/°C)	R (T) / R25	TF (%)	α (%/°C)	R (T) / R25	TF (%)	α (%/°C)	
-55	61.21	7.1	6.77	104.2	3.9	7.89	109.5	8.0	7.83	-55
-50	44.24	6.1	6.53	71.63	3.4	7.57	75.42	6.9	7.54	-50
-45	32.33	5.3	6.30	49.94	2.9	7.28	52.63	6.0	7.27	-45
-40	23.88	4.5	6.08	35.28	2.5	7.00	37.18	5.1	7.01	-40
-35	17.81	3.8	5.88	25.25	2.1	6.73	26.58	4.3	6.76	-35
-30	13.41	3.2	5.68	18.28	1.8	6.48	19.22	3.7	6.52	-30
-25	10.19	2.7	5.49	13.39	1.5	6.25	14.04	3.1	6.30	-25
-20	7.814	2.2	5.31	9.917	1.2	6.02	10.37	2.5	6.09	-20
-15	6.040	1.8	5.14	7.419	1.0	5.81	7.730	2.1	5.89	-15
-10	4.707	1.5	4.98	5.605	.8	5.61	5.817	1.6	5.70	-10
-5	3.696	1.1	4.83	4.275	.6	5.42	4.416	1.3	5.51	-5
0	2.923	.9	4.68	3.289	.5	5.24	3.382	1.0	5.34	0
5	2.329	.6	4.53	2.552	.3	5.06	2.611	.7	5.17	5
10	1.867	.4	4.40	1.997	.2	4.90	2.032	.5	5.01	10
15	1.507	.3	4.27	1.574	.1	4.74	1.593	.3	4.86	15
20	1.224	.1	4.14	1.250	.1	4.59	1.258	.1	4.71	20
25	1.0000	0.0	4.02	1.0000	0.0	4.45	1.0000	0.0	4.57	25
30	.8217	.1	3.91	.8053	.1	4.31	.8004	.1	4.44	30
35	.6788	.2	3.80	.6527	.1	4.18	.6446	.3	4.31	35
40	.5638	.4	3.69	.5323	.2	4.06	.5224	.4	4.19	40
45	.4707	.5	3.59	.4367	.3	3.94	.4258	.6	4.07	45
50	.3948	.7	3.49	.3604	.4	3.82	.3491	.8	3.96	50
55	.3328	.9	3.40	.2990	.5	3.71	.2877	1.0	3.85	55
60	.2818	1.0	3.31	.2493	.6	3.61	.2383	1.2	3.74	60
65	.2396	1.2	3.22	.2090	.7	3.51	.1984	1.4	3.64	65
70	.2046	1.4	3.14	.1760	.8	3.41	.1660	1.6	3.55	70
75	.1754	1.6	3.06	.1489	.9	3.32	.1396	1.8	3.45	75
80	.1510	1.8	2.98	.1266	1.0	3.23	.1178	2.1	3.36	80
85	.1305	2.0	2.90	.1081	1.1	3.14	.09991	2.3	3.28	85
90	.1131	2.3	2.83	.09262	1.2	3.06	.08507	2.5	3.20	90
95	.09846	2.5	2.76	.07970	1.3	2.98	.07273	2.8	3.12	95
100	.08597	2.7	2.69	.06885	1.5	2.91	.06241	3.0	3.04	100
105	.07531	2.9	2.63	.05969	1.6	2.83	.05376	3.3	2.96	105
110	.06618	3.1	2.56	.05194	1.7	2.76	.04648	3.5	2.89	110
115	.05834	3.4	2.50	.04535	1.8	2.69	.04032	3.8	2.82	115
120	.05158	3.6	2.44	.03973	2.0	2.63	.03510	4.1	2.76	120
125	.04573	3.8	2.39	.03491	2.1	2.56	.03065	4.3	2.69	125
130	.04066	4.0	2.33	.03077	2.2	2.50	.02685	4.6	2.63	130
135	.03625	4.3	2.28	.02721	2.3	2.44	.02359	4.8	2.57	135
140	.03240	4.5	2.23	.02412	2.5	2.39	.02079	5.1	2.51	140
145	.02903	4.7	2.18	.02145	2.6	2.33	.01838	5.4	2.45	145
150	.02608	5.0	2.13	.01912	2.7	2.28	.01629	5.6	2.40	150

T (°C)	Material code B (K)									T (°C)
	PA 4235			QA 4250			RA 4380			
	R (T) / R25	TF (%)	α (%/°C)	R (T) / R25	TF (%)	α (%/°C)	R (T) / R25	TF (%)	α (%/°C)	
-55	123.3	8.3	8.00	101.8	8.3	7.36	110.7	8.6	7.53	-55
-50	84.31	7.2	7.71	71.33	7.2	7.13	77.22	7.4	7.29	-50
-45	58.37	6.2	7.43	50.51	6.2	6.91	54.43	6.4	7.07	-45
-40	40.92	5.3	7.17	36.14	5.3	6.70	38.76	5.5	6.85	-40
-35	29.03	4.5	6.92	26.11	4.5	6.50	27.86	4.6	6.65	-35
-30	20.83	3.8	6.69	19.05	3.8	6.31	20.22	3.9	6.46	-30
-25	15.10	3.2	6.46	14.02	3.2	6.12	14.81	3.3	6.27	-25
-20	11.07	2.6	6.25	10.41	2.6	5.85	10.94	2.7	6.09	-20
-15	8.189	2.1	6.05	7.791	2.1	5.78	8.143	2.2	5.92	-15
-10	6.117	1.7	5.85	5.879	1.7	5.62	6.112	1.8	5.76	-10
-5	4.610	1.3	5.67	4.470	1.3	5.46	4.622	1.4	5.60	-5
0	3.504	1.0	5.49	3.424	1.0	5.31	3.522	1.0	5.45	0
5	2.686	.7	5.32	2.642	.7	5.17	2.702	.8	5.31	5
10	2.075	.5	5.16	2.052	.5	5.03	2.087	.5	5.17	10
15	1.615	.3	5.01	1.605	.3	4.90	1.623	.3	5.03	15
20	1.266	.1	4.86	1.263	.1	4.77	1.270	.1	4.91	20
25	1.0000	0.0	4.72	1.0000	0.0	4.65	1.0000	0.0	4.78	25
30	.7949	.1	4.58	.7965	.1	4.53	.7920	.1	4.66	30
35	.6359	.3	4.45	.6380	.3	4.42	.6308	.3	4.55	35
40	.5119	.4	4.32	.5139	.4	4.31	.5052	.5	4.43	40
45	.4145	.6	4.20	.4162	.6	4.20	.4068	.6	4.33	45
50	.3376	.8	4.09	.3388	.8	4.10	.3292	.8	4.22	50
55	.2765	1.0	3.98	.2771	1.0	4.00	.2678	1.0	4.12	55
60	.2276	1.2	3.87	.2278	1.2	3.90	.2189	1.3	4.02	60
65	.1883	1.4	3.77	.1881	1.4	3.81	.1797	1.5	3.93	65
70	.1566	1.7	3.67	.1560	1.7	3.72	.1483	1.7	3.84	70
75	.1308	1.9	3.58	.1300	1.9	3.63	.1228	2.0	3.75	75
80	.1098	2.1	3.48	.1088	2.1	3.55	.1022	2.2	3.67	80
85	.09258	2.4	3.40	.0914	2.4	3.47	.08537	2.5	3.58	85
90	.07838	2.6	3.31	.07708	2.6	3.39	.07160	2.7	3.50	90
95	.06662	2.9	3.23	.06527	2.9	3.31	.06029	3.0	3.42	95
100	.05686	3.1	3.15	.05547	3.2	3.24	.05095	3.2	3.35	100
105	.04871	3.4	3.07	.04731	3.4	3.17	.04322	3.5	3.28	105
110	.04189	3.7	3.00	.04049	3.7	3.10	.03679	3.8	3.21	110
115	.03614	3.9	2.93	.03478	3.9	3.03	.03143	4.1	3.14	115
120	.03130	4.2	2.86	.02996	4.2	2.96	.02693	4.3	3.07	120
125	.02719	4.5	2.79	.02590	4.5	2.90	.02316	4.6	3.01	125
130	.02370	4.7	2.73	.02246	4.7	2.84	.01997	4.9	2.94	130
135	.02072	5.0	2.67	.01953	5.0	2.78	.01728	5.2	2.88	135
140	.01817	5.3	2.61	.01704	5.3	2.72	.01499	5.4	2.82	140
145	.01598	5.5	2.55	.01490	5.5	2.67	.01305	5.7	2.77	145
150	.01410	5.8	2.49	.01307	5.8	2.61	.01138	6.0	2.71	150

Manufacturing Process for Thermistors NTC

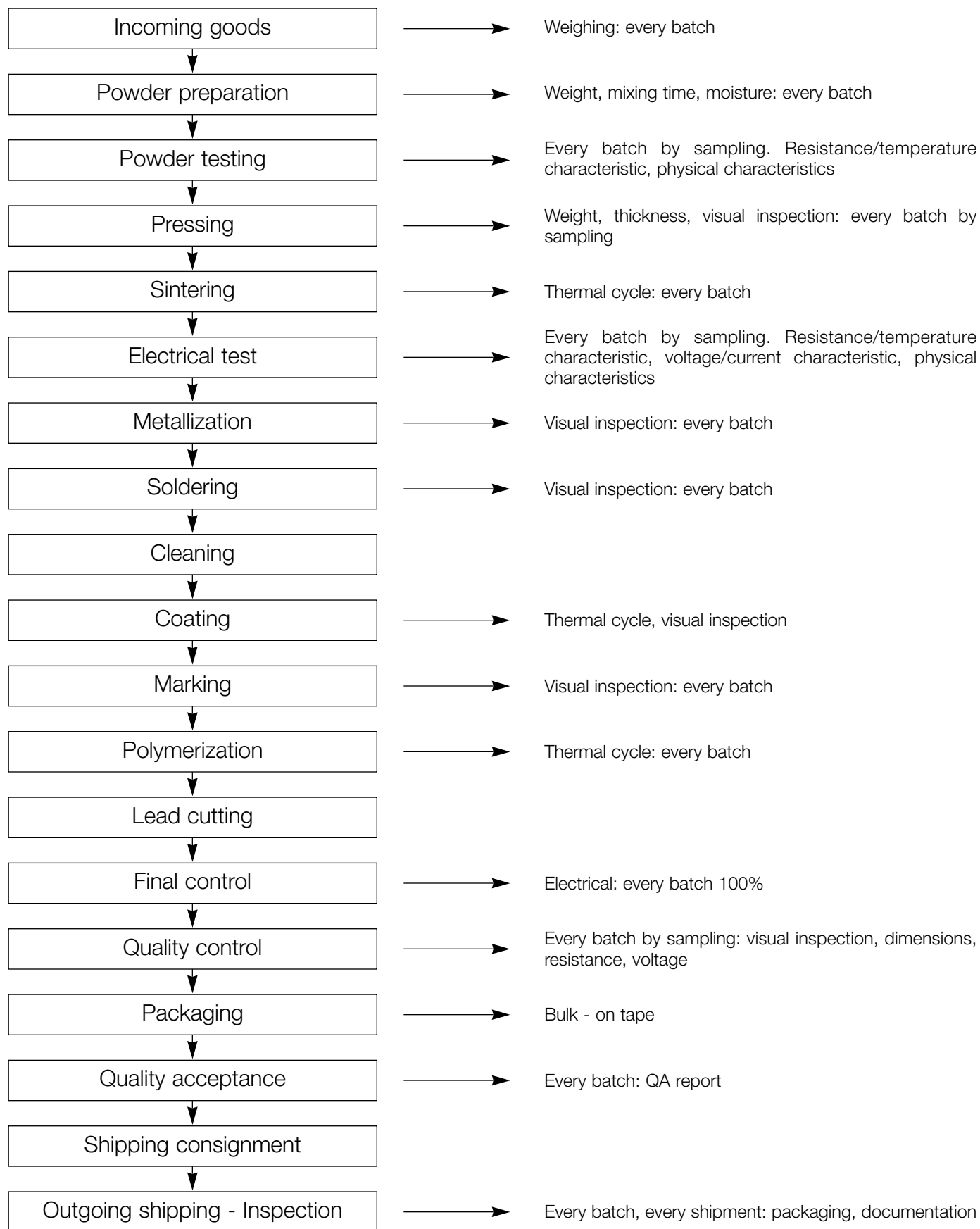

Test	Conditions of Test	Performance Requirements
B - Value	$B = \frac{1}{(1/T_1 - 1/T_2)} \ln \frac{R_1}{R_2}$ with $T_1 = 298.16$ K and $T_2 = 358.16$ K	Values within the limits specified
Robustness of terminations	Tensile, bending and torsion tests (10 N, 2 bends, 2 torsions 180°) (5 N for 0.3 mm leads)	No visual damage $\Delta R/R < 5\%$
Solderability	235°C / 2 s	> 95% of the surface of the lead wires covered
Resistance to soldering heat	260°C / 30 s	No visual damage $\Delta R/R < 5\%$
Vibration	Cycle 10 Hz / 55 Hz / 10 Hz – 1 mn amplit. 0.75 mm / 6 h / 3 axes	No visual damage $\Delta R/R < 5\%$
Rapid change of temperature	5 cycles / 1 h min recovering (30 mn Tmin / 3 mn 25°C / 30 mn Tmax / 3 mn 25°C)	No visual damage $\Delta R/R < 10\%$
Climatic sequence	16 h / Tmax / dry heat 24 h / 55°C / 95% R.H. 2 h / Tmin 24 h / 55°C / 95% R.H. Recovering 55°C / 24 h / dry heat	No visual damage $\Delta R/R < 10\%$
Endurance at ambient temperature	1000 h / 25°C	No visual damage $\Delta R/R < 5\%$
Endurance at maximum operating temperature at zero-power dissipation	1000 h / Tmax	No visual damage $\Delta R/R < 10\%$
Endurance at ambient temperature at maximum rated dissipation	1000 h / 25°C Rated dissipation 1.5 h / recov. 0.5 h	No visual damage $\Delta R/R < 10\%$
Damp heat, steady-state	40°C / 93% R.H. Nb days according to clim. categ.	No visual damage $\Delta R/R < 10\%$

IDENTIFICATION - TRACEABILITY

On the packaging of all shipped thermistors, you will find a bar code label.

This label gives systematic information on the type of product, part number, lot number, manufacturing date and quantity.

An example is given below:

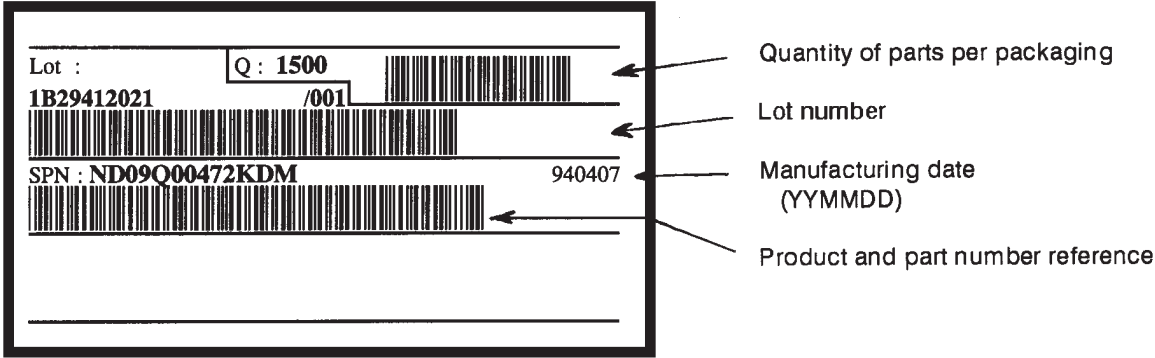

This information allows complete traceability of the entire manufacturing process, from raw materials to final inspection.

This is extremely useful for any information request, customer complaint or product return.

BULK PACKAGING

Type	Qty / Box	Type	Qty / Box	Type	Qty / Box
NC 12/20	1000	ND 03	3000	PE 04	1000
NB 12/20/21	1000				
NJ 28	2000	ND 06	1500	PE 06	1000
NK 20	5000	ND 09	1500	PE 08	1000
NA/NL 19		NF 08	450	PE 10	800
NA/NL 57		NF 10	450	PE 12	500
NM 06		NF 13	400	PE 16	400
NV 21	according	NF 15	250	PE 20	250
NV 03	to				
NV 06	P/N	NF 20	150		
NV 09					
NR					

Packaging for Automatic Insertion



Chip Thermistors NTC / NC Series

AUTOMATIC INSERTION

Super 8 plastic tape packaging

The mechanical and dimensional reel characteristics are in accordance with the IEC publication 286-3.

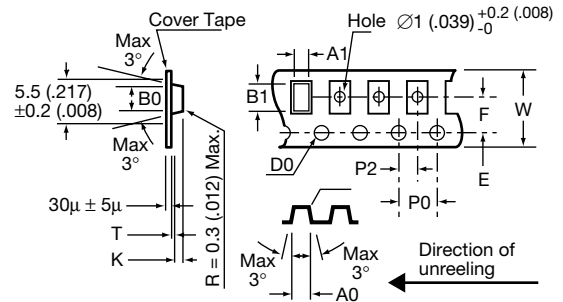

Designation	Symbol	Value	Tolerance
Tape width	W	8	±0.2
Tape thickness	T	0.4 max.	
Pitch of the sprocket holes	P0	4	±0.1
Diameter of the sprocket holes	D0	1.5 -0	±0.1
Distance	E	1.75	±0.1
Distance (center to center)	F	3.5	±0.05
Distance (center to center)	P2	2	±0.1
Sizes of the NC 12 (0805)	A0	1.5	±0.1
	B0	2.4	±0.1
	K	1.4 max.	K ±0.1 (size is adjustable) (K = t1 +0.2)
NC 20 (1206)	A0	1.95	±0.1
	B0	3.55	±0.1
	K	1.5 max.	K ±0.1 (size is adjustable) (K = t1 +0.2)

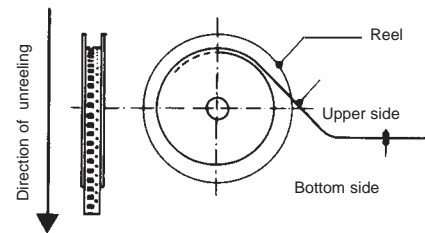
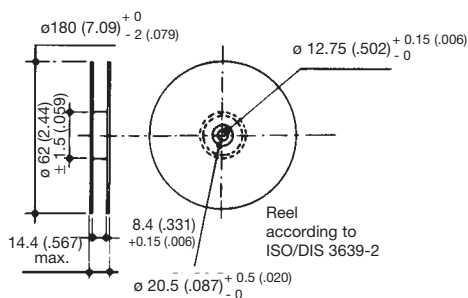

QUANTITY PER REEL

Type	Suffix	Qty Per Reel
NC - NB 12	BA	4000
NB 21	BE	2000
NC 20 - NB 20	BA	3000
	BE	1500

Disc Thermistors NTC

PACKAGING AND KINK SUFFIXES

Tables below indicate the suffixes to specify when ordering to get the required kink and packaging. For devices on tape, it is necessary to specify the height (H or Ho) which is the distance between the tape axis (sprocket holes axis) and the seating plane on the printed circuit board. The following types can be ordered on tape either in AMMOPACK (fan folder) or on REEL in accordance with IEC 286-2.

– Straight leads:

H represents the distance between the sprocket holes axis and the bottom plane of component body (base of resin or base of stand off).

– Kinked leads and flat leads:

Ho represents the distance between the sprocket holes axis and the base on the knee (kinked leads) or the bottom of the flat part (flat leads).

NTC

Type ND 03

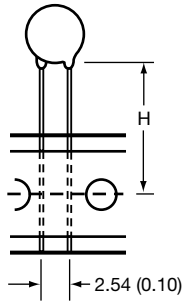

millimeters (inches)

Suffix	H	Leads	Packaging
CA	16 (.630) ±0.5 (.020)	Straight	AMMOPACK
CB	16 (.630) ±0.5 (.020)	Straight	REEL
CC	19.5 (.768) ±0.5 (.020)	Straight	AMMOPACK
CD	19.5 (.768) ±0.5 (.020)	Straight	REEL

NTC

Types ND06/09 NV06/09

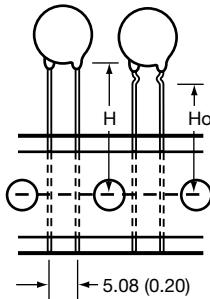

millimeters (inches)

Suffix	H or Ho	Leads	Packaging
DA	16 (.630) ±0.5 (.020)	Straight	AMMOPACK
DB	16 (.630) ±0.5 (.020)	Straight	REEL
DC	19.5 (.768) ±0.5 (.020)	Straight	AMMOPACK
DD	19.5 (.768) ±0.5 (.020)	Straight	REEL
DL	16 (.630) ±0.5 (.020)	Kinked	AMMOPACK
DM	16 (.630) ±0.5 (.020)	Kinked	REEL
DN	19.5 (.768) ±0.5 (.020)	Kinked	AMMOPACK
DP	19.5 (.768) ±0.5 (.020)	Kinked	REEL

PACKAGING QUANTITIES

Quantity Per Size			
Product	Type	AMMOPACK	REEL
NTC	ND 03	3000	3000
	ND - NV 06	1500	1500
	ND - NV 09	1500	1500

Packaging for Automatic Insertion



Disc Thermistors NTC / NF Series

PACKAGING AND KINK SUFFIXES

The following types can be ordered on tape either in AMMOPACK (fan folder) or on REEL in accordance with IEC 286-2.

Types	Straight		NF08		"Y" Kink	
Leads	Straight		Internal Kink		"Y" Kink	
DIMENSIONS: millimeters (inches)						
	Packaging	AMMOPACK	REEL	AMMOPACK	REEL	AMMOPACK
Ho = 16	DA	DB	DQ	DR	D7	D5
Ho = 19.5	DC	DD	DS	DT	D8	D6

Types	Straight		NF08 / 10 / 13		"Y" Kink	
Leads	Straight		Internal Kink		"Y" Kink	
DIMENSIONS: millimeters (inches)						
	Packaging	AMMOPACK	REEL	AMMOPACK	REEL	AMMOPACK
Ho = 16	EA	EN	EC	EF	EQ	ER
Ho = 19.5	EB	ED				

PACKAGING QUANTITIES

Type	AMMOPACK	REEL
NF08* (5.08)	1000	1000
NF08 (7.62)	750	750
NF10* (5.08)	–	–
NF10 (7.62)	750	750
NF13 (7.62)	750	750
NF15 (7.62)	–	–
NF20 (7.62)	–	–

Disc Thermistors NTC

TAPING CHARACTERISTICS

Missing components

A maximum of 3 consecutive components may be missing from the bandolier, surrounded by at least 6 filled positions. The number of missing components may not exceed 0.5% of the total per packing module.

The beginning and the end of tape exhibit 8 or 9 blank positions.

DIMENSIONS: millimeters (inches)

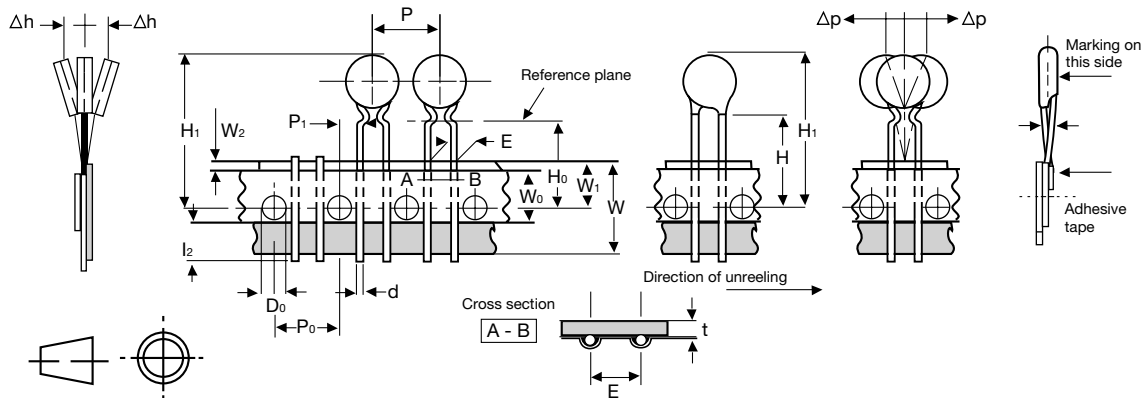
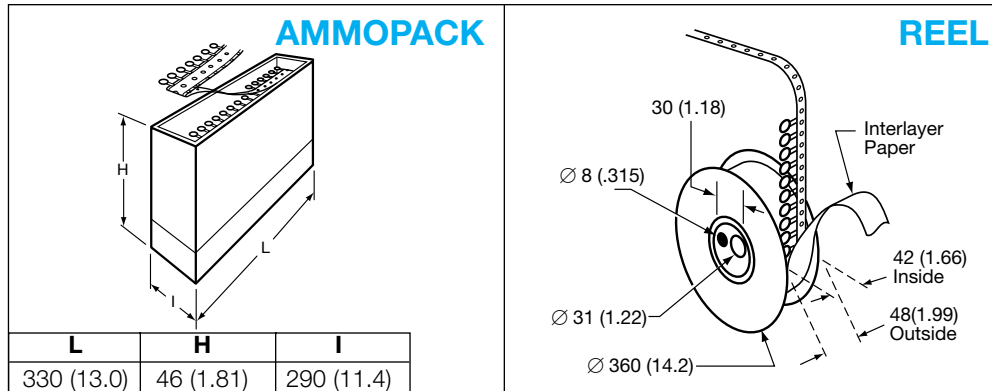

Value	Tolerance	Dimensions Characteristics
18	+1 / -0.5	W Leading tape width
6	±0.3	W ₀ Adhesive tape width
9	+0.75 / -0.5	W ₁ Sprocket hole position
3 max.		W ₂ Distance between the top of the tape and the adhesive
4	±0.2	D ₀ Diameter of sprocket hole
16/19.5	±0.5	H ₀ Distance between the tape axis and the seating plane of the component
		H ₁ Distance between the tape axis and the top of component body

Value	Tolerance	Dimensions Characteristics
12.7	±0.2	P ₀ Sprocket holes pitch
254	±1	- Distance between 21 consecutive holes 20 pitches
0.7	±0.2	t Total thickness of tape
2.54	+0.6 / -0.1	F Lead spacing
5.08	± 0.7	P ₁ Distance between the sprocket hole axis and the lead axis
12.7	±1.0	P Spacing of components
0.5	±5%	d Lead diameter
0	±1.3	°P Verticality of components
0	±2	°h Alignment of components

USA

AVX Myrtle Beach, SC Corporate Offices

Tel: 843-448-9411
FAX: 843-448-1943

AVX Northwest, WA

Tel: 360-669-8746
FAX: 360-699-8751

AVX North Central, IN

Tel: 317-848-7153
FAX: 317-844-9314

AVX Northeast, MA

Tel: 508-485-8114
FAX: 508-485-8471

AVX Mid-Pacific, CA

Tel: 408-436-5400
FAX: 408-437-1500

AVX Southwest, AZ

Tel: 602-539-1496
FAX: 602-539-1501

AVX South Central, TX

Tel: 972-669-1223
FAX: 972-669-2090

AVX Southeast, NC

Tel: 919-878-6357
FAX: 919-878-6462

AVX Canada

Tel: 905-564-8959
FAX: 905-564-9728

EUROPE

AVX Limited, England European Headquarters

Tel: ++44 (0)1252 770000
FAX: ++44 (0)1252 770001

AVX S.A., France

Tel: ++33 (1) 69.18.46.00
FAX: ++33 (1) 69.28.73.87

AVX GmbH, Germany - AVX

Tel: ++49 (0) 8131 9004-0
FAX: ++49 (0) 8131 9004-44

AVX GmbH, Germany - Elco

Tel: ++49 (0) 2741 2990
FAX: ++49 (0) 2741 299133

AVX srl, Italy

Tel: ++39 (0)2 665 00116
FAX: ++39 (0)2 614 2576

AVX sro, Czech Republic

Tel: ++420 (0)467 558340
FAX: ++420 (0)467 2844

ASIA-PACIFIC

AVX/Kyocera, Singapore Asia-Pacific Headquarters

Tel: (65) 258-2833
FAX: (65) 350-4880

AVX/Kyocera, Hong Kong

Tel: (852) 2-363-3303
FAX: (852) 2-765-8185

AVX/Kyocera, Korea

Tel: (82) 2-785-6504
FAX: (82) 2-784-5411

AVX/Kyocera, Taiwan

Tel: (886) 2-2516-7010
FAX: (886) 2-2506-9774

AVX/Kyocera, China

Tel: (86) 21-6249-0314-16
FAX: (86) 21-6249-0313

AVX/Kyocera, Malaysia

Tel: (60) 4-228-1190
FAX: (60) 4-228-1196

Elco, Japan

Tel: 045-943-2906
FAX: 045-943-2910

Kyocera, Japan

Tel: (81) 75-593-4518
FAX: (81) 75-502-2705

Contact:

