

## Lithium-ion Cylindrical Battery

Primary characteristics		
Parameter	Value	Unit
Nominal voltage	3.2	V
Rated capacity	1500	mAh

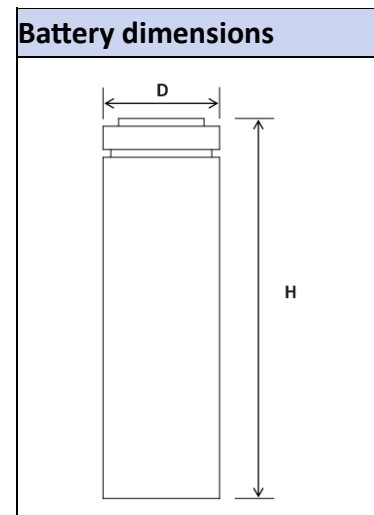

### Scope

The purpose of this product specification is to provide technical information for the rechargeable Lithium-ion cylindrical battery IFR18650.

The test shall be conducted in strict accordance with the method specified in this specification.

If you have any objection to the test items or test methods, please contact Akyga Battery.

Specification table		
Parameter	Value	
Model	IFR18650-15M	
Typical voltage	3.2V	
Rated capacity	Typical	1500mAh
	Minimum	1450mAh
Standard charge	CCCV 0.2C, 4.2±0.05V, 0.02C cut-off	
Rapid charge	CCCV 0.5C, 4.2±0.05V, 0.02C cut-off	
Standard continuous Discharge	DC, 0.2C, 2.0V cut-off	
Maximum continuous Discharge	DC, 1C, 2.0V cut-off	
Charge/Discharge voltage range	4.20~2.0V	
Operation Temperature	Charge: 0~15°C	≤0.2C
	Charge: 15~45°C	≤0.5C
	Discharge: -20~60°C	
Storage Temperature	1 year	0~25°C
	3 months	0~45°C
	1 month	0~60°C
Cycle life	After 300 <sup>th</sup> cycles>95%, 500 <sup>th</sup> cycles>85%, 1000 <sup>th</sup> cycles>70%	
Size	Diameter	18.0 ±0.2 mm
	Height	65.0 ±0.15 mm
Weight Approx	50g	
Notes: Rated capacity test conditions: Charge: 0.2C, 4.2V, CCCV 0.02C cut-off Discharge: 0.2C, 2.0V, DC cut-off voltage Cycle life: Charge CCCV 0.5C, 4.2±0.05V, 0.02C cut-off, discharge: DC, 1C, 2.0V cut-off, rest time: 10 min after charging and 30 min after discharge.		

**Appearance:**

There shall be no such defects as rust, discoloration, leakage which may adversely affect commercial value of the cell.

**Standard Test condition:**

**Environment Condition –**

Unless otherwise specified, all tests stated in this specification are conducted at temperature 25±2°C and humidity under 65% RH.

**Measuring Equipment –**

1. AMP-meter and volt-meter  
The amp-meter and volt-meter should have an accuracy of the grade 0.5mA and 0.5mV or higher
2. Slide caliper  
The slide caliper should have 0.01mm scale.
3. Impedance meter  
The impedance meter with AC 1kHz should be used.

**Characteristics**

1. **Standard Charge**  
Standard charge means charging the cell CCCV with charge current 0.2C, constant voltage 4.2V and 0.02C cut-off in CV mode at 25°C for capacity.
2. **Rapid Charge**  
Rapid Charge means charging the cell CCCV with charge current 0.5C, constant voltage 4.2V and 0.02C cut-off in CV mode at 25°C
3. **Standard Discharge Capacity**  
The Standard Discharge Capacity is the initial discharge capacity of the cell, which is measured with discharge current 0.2C with 2.0V cut-off at 25°C within 1 hour after the standard charge  
Discharge Capacity ≥ 1500mAh
4. **Temperature dependence of discharge capacity**  
Capacity comparison at each temperature, measured after 3 hours storage at the test environment with discharge constant current 0.2C and 2.0V cut-off after the standard charge at 25°C

Item	Discharge temperature		
	-20°C	25°C	55°C
Relative Capacity	≥70%	100%	≥90%

**Note:** Relative capacity is divided by the 0.2C discharge capacity at 25°C

5. **Storage**  
The Li-Ion battery pack should be stored in a cool, dry and well-ventilated area. Shall keep out of fire or heat and avoid touching corrosion elements. The batteries shall be charged every 6 months during storage.
6. **Status of the cell as of ex-factory**  
The cell should be shipped in 3.55V to 3.60V charging voltage range.

**Mechanical Characteristics**

1. **Drop test**  
Test method: Each fully charged cell is dropped three times from a height of 1.0m onto a concrete floor at 20±5°C. The cells are dropped so as to obtain impacts in random orientations. After the test, the cells shall be put on rest for a minimum one hour and then a visual inspection shall be performed.  
Criteria: no fire, no explosion.  
Drop test shall be performed with the IEC62133 standard.
2. **Vibration test**  
Test method: For X and Y axis with cylindrical cell 7Hz→200Hz→7Hz for 15 minutes, repetition 12 times totally 3 hours, the acceleration 1g during 7 to 18Hz, then amplitude 1.6mm and maximum 8g to 200Hz. Test are to be conducted at 20±5°C  
Criteria: no fire, no explosion, no leakage, with less than 10% of OCV drop.  
Vibration test shall be performed with the UN38.3 standard.

**Battery structure**

Protection CID + PTC

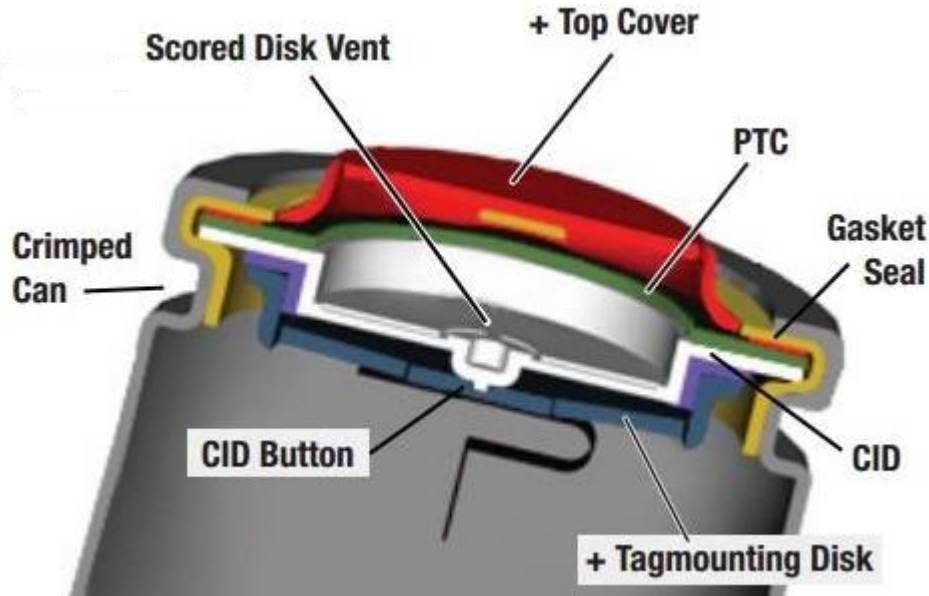
**Caution**

The battery used in this device may present a risk of fire or chemical burn if mistreated.

Do not disassemble, expose to heat above 100°C or incinerate it.

Do not expose the cell to extreme heat or flame.

Do not short circuit, over-charge or over-discharge the cell.

Do not subject the cell to strong mechanical shocks.

Do not immerse the cell in water or sea water, or get it wet.

Do not reverse the polarity of the cell for any reason.

Do not disassemble or modify the cell.

Do not handle or store with metallic like necklaces, coins or hairpins, etc.

Do not connect cell to the plug socket or car-cigarette-plug.

Do not make the direct soldering onto a cell

Do not touch a leaked cell directly.

Do not use Lithium-ion cell in mixture.

Do not use or leave the cell under the blazing sun (or In heated car by sunshine).

Keep cell away from children.

Do not drive a nail into the cell, strike it by hammer or tread it.

Replace battery with those of Akyga battery only.

## Disclaimer

Akyga battery reserves the right to make changes without notice to any product specification herein, to make corrections, modifications, enhancements or other changes. Akyga battery or anyone on its behalf assumes no responsibility or liability for any errors or inaccuracies. Data sheet specifications and its information contained are intended to provide a product description only. "Typical" parameters which may be included on Akyga battery data sheets and/ or specifications can and do vary in different applications and actual performance may vary over time. Akyga battery does not assume any liability arising out of the application or use of any product or circuit. Akyga battery products are not designed, intended or authorized for use in medical, life-saving implant or other applications intended for life-sustaining or other related applications where a failure or malfunction of component or circuitry may directly or indirectly cause injury or threaten a life without expressed written approval of Akyga battery. Customers using or selling Akyga battery components for use in such applications do so at their own risk and shall agree to fully indemnify Akyga battery and its subsidiaries harmless against all claims, damages and expenditures.